

SPS -48V Slimline Power Shelf

Models: J2007003L002 – alpha suffixes per Slimline Power System Brochure



Battery CB - some models

No vertical spacing is required, allow a minimum 2 inch clearance at back of shelf for rectifier airflow.
Refer to Slimline Power System Brochure for details and accessories.

Tools required:

- Wire cutters and strippers
- Torque wrench - 0-65 in-lb (0-10 Nm)
- Screwdrivers - Phillips #1 and #2, Flat small
- Cable crimpers
- Sockets - 5/16", 7/16, etc.

Step 1 – Mount Shelf

1. Reposition mounting ears as required - 1 screw each.
Torque to 25 in-lb (2.8 Nm) - Phillips screwdriver.
2. Attach shelf to the frame using a minimum of four screws (two on each side) - 12-24 (provided).
Torque to 35 in-lb (4 Nm) - 5/16" socket.

Step 2 – Connect Chassis Ground and DC Reference (CO) Ground

Lug Landings: #10 double-hole on 5/8-inch center (lugs not provided)

Some applications may rely on frame mounting screws for chassis ground, omitting the chassis ground wire.

Some applications may use the Chassis Ground strap, using a single wire for both chassis ground and DC reference ground.

Minimum 10 AWG wire is recommended.

Torque 10-32 screws to 30 in-lb (3.4 Nm) - 5/16" socket.

Step 3 – Connect AC Input

Connect AC cords - 1 or 2 C13 cords

Secure cord with the furnished AC retention clamps.

Danger: If blunt cut cords are used ensure AC power is OFF and use appropriate lock-out tag-out procedures before continuing with ac connections. Follow all local and national wiring rules when connecting to ac mains.

CAUTION: Route AC cables to avoid contact with sharp or rough surfaces that may damage insulation and cause a short circuit.

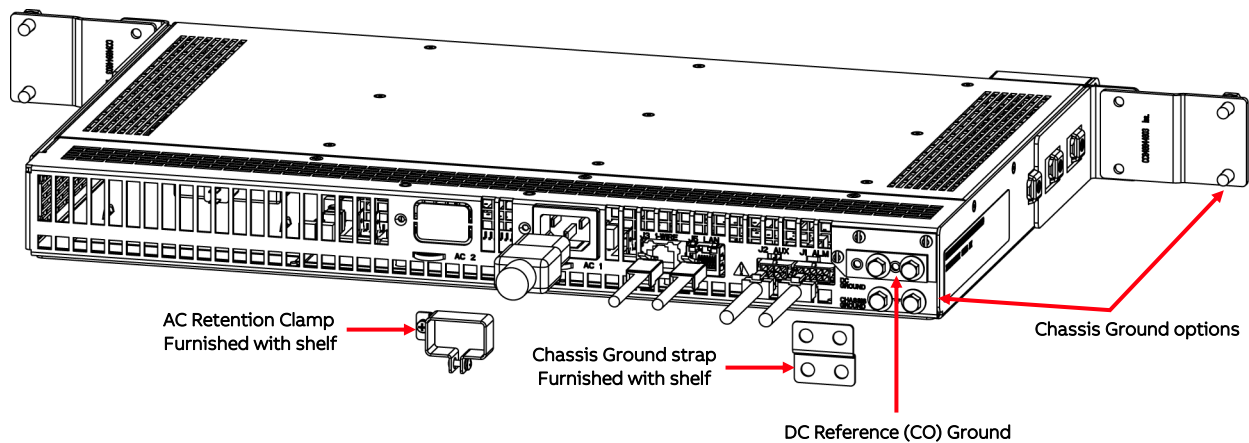

Step 4 – Connect DC Output and Batteries

CAUTION: Verify battery voltage and polarity with a voltmeter before proceeding.

Note: RETURN must be externally connected to DC Reference (CO) ground.

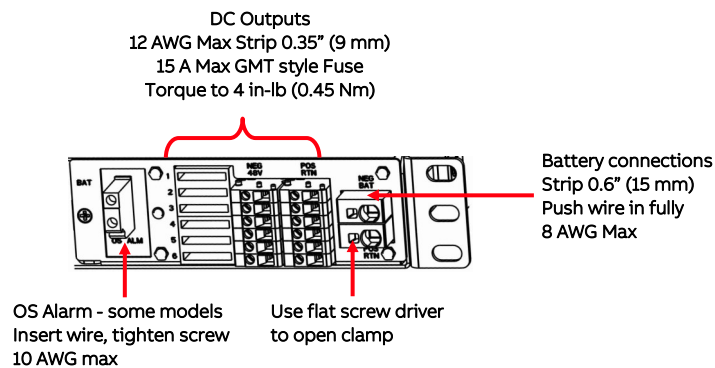

Step 5 – Connect Open String Alarm – Some Models - Optional

Connect OS Alarm as directed in site installation instructions.

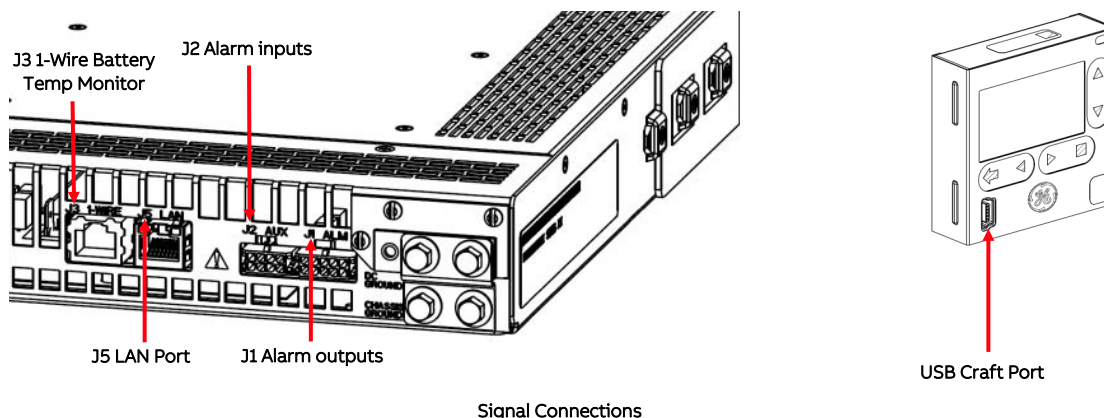

Step 6 – Set Jumpers – LAN Port and Relay per Galaxy Pulsar Edge Controller Quick Start Guide

Step 7 – Install Controller per Galaxy Pulsar Edge Controller Quick Start Guide

Step 8 – Install Signal and Communications Cables

Connectors are on rear.

1. J1-2 Alarms and Inputs - Connect to office alarms and signals.
See Information: Alarm Connections for Details
2. J5 LAN - Connect to Ethernet network.

Step 9 – Install 1-Wire Battery Temp and Voltage Monitor per Galaxy Pulsar Edge Controller Quick Start Guide – Optional

1. Connect 1-Wire Battery Temp and Voltage Monitor to J3.

Step 10 – Install Rectifiers

Firmly push the rectifier into the rectifier slot.

Tighten the thumb screw until the rectifier is seated.

NOTE: When installing a rectifier in a powered system the RUN LED on the rectifier will blink until communication with the controller is established.



Step 11 – Initial Start Up

Verify that all AC, DC and Alarm connections are complete and secure. Turn on AC input breakers. If there are no alarms, make required adjustments to the default settings on the controller for this installation.

Step 12 – Configure Controller per Galaxy Pulsar Edge Controller Quick Start Guide

Verify and edit controller basic configuration parameters per site engineering instructions.

Information: Rectifier Options

Rectifiers single phase, hot-pluggable, fan-cooled		Input		Recommended AC Breaker		Output		
		Vac	A	2 - C13 AC Cords	1 - C13 AC Cord	Float Vdc	W	A ¹
150027894	EP0500-UTEZ: 540W	100-120	6.5	10A	20A	48-58	540	10
CC109165602	EP1000-UTEZ: 1000W	100-120	12	15A		48-58	1000	20
		200-240	6	10A	15A	48-58	1000	20
CC109165610	EP1600-UTEZ: 1600W	100-120	15	20A		48-58	1200	24
		200-240	7.5	10A	20A	48-58	1600	32

¹Output Current at 54.5V. Outputs are power limited, not current limited.

Information: Alarm Connections

See the Slimline Power System Brochure for details.

Alarm connections are on the rear of the shelf - J1 is Alarm Outputs and J2 is Alarm Inputs.

Change alarm descriptions via LAN port (Web pages) or Craft port (EasyView2) when required.

Connector		J1 – Controller Variants				J2 – All Controllers	
Pin	Controller	Color	0I5R_D – 5 Alarm	3C3R – 3 Alarm	9C0R_USB – 9 Inputs	Color	All
1		BK	Output: R3 = Rtn	Input: PBT/TR	Input: Door Open	Y	Input: SPD Fail
2		BR	Output: R2 = Rtn	Input: Hi Ext. Temp.	Input: Surge Protect Fail	S	--
3		R	Output: R1 = Rtn	Output: R1 = Rtn	Input: Door 2 Open	O	Input: AUX MAJ
4		O	Output: PMN Rtn	Output: PMN Rtn	Input: Ext DC Gail Major	V	Input: Air Cond. Fail
5		Y	Output: PMJ Rtn	Output: PMJ Rtn	Input: Ext DC Fail Minor	W	Input: Door Open
6		G	Output: R3 = ACF	Input: RTNS	Input: Returns	BL	-48V
7		BL	Output: R2 = RFA	Input: Cust. Alm 1	Input: Retrieve Generator	BR	-48V
8		V	Output: R1 = BD	Output: R1 = BD	Input: Battery Fail	BK	-48V
9		S	Output: PMN	Output: PMN	Input: Air Conditioner Fail		
10		W	Output: PMJ	Output: PMJ	Input: External Fan Fail		

Specifications and Application

- Specifications and ordering information are in the Slimline Power System Brochure available at www.abbpowerconversion.com
- External Surge Protective Devices (SPDs) - are required on all AC inputs.
Equipment Safety is Approved in IEC 60664-1 Installation Category II environments.
- Equipment and subassembly ports:
 1. are suitable for connection to intra-building or unexposed wiring or cabling;
 2. can be connected to shielded intra-building cabling grounded at both ends.
- Grounding / Bonding Network – Connect to an Isolated Ground Plane (Isolated Bonding Network) or an Integrated Ground Plane
(Mesh-Bonding Network or Common Bonding Network).
- Installation Environment - Install in Network Telecommunication Facilities, OSP, or where NEC applies.
- Battery return may be either Isolated DC return (DC-I) or Common DC return (DC-C).

Reference Documents

These documents are available at www.abbpowerconversion.com

Document	Title
850035894	Galaxy Pulsar Edge Quick Start Guide
CC848815341	Pulsar Edge Controller Family Product Manual
	Slimline Power System Brochure

Safety Statements

- Do not install this equipment over combustible surfaces.
- Rules and Regulations - Follow all national and local rules and regulations when making field connections.
- Compression Connectors
 - US or Canada installations - use Listed/Certified compression connectors to terminate Listed/Certified field-wire conductors.
 - All installations - apply the appropriate connector to the correct size conductor as specified by the connector manufacturer, using only the connector manufacturer's recommended or approved tooling for that connector.
- Electrical Connection Securing: Torque to the values specified on labels or in the product documentation.
- Cable Dress - dress to avoid damage to the conductors and undue stress on the connectors.
- Circuit Breakers and Fuses
 - Use only those specified in the equipment ordering guide.
 - Size as required by the National Electric Code (NEC) and/or local codes.
 Safety Tested Limits - Refer to the equipment ratings to assure current does not exceed:
 Continuous Load (List 1) - 60% of protector rating
 Maximum Load (List 2 - typically end of discharge) - 80% of protector rating
 - GMT Style Fuses - Use only fuses provided with safety caps.
- Field-wired Conductors - Follow all National Electric Code (NEC) and local rules and regulations.
 - Insulation rating: 90°C minimum; 105°C (minimum) if internal to enclosed equipment cabinets.
 - Size AC field-wired conductors with 75°C ampacity (NEC) equal to or greater than their panel board circuit breaker rating.
- AC and DC input disconnect/protection - Provide accessible devices to remove input power in an emergency.
- Alarm Signals - Provide external current limiting protection. Rating 60V, 0.5A unless otherwise noted.
- Grounding - Connect the equipment chassis directly to ground. In enclosed equipment cabinets connect to the cabinet AC service ground bus. In huts, vaults, and central offices connect to the system bonding network.

Precautions

- Install, service, and operate equipment only by professional, skilled and qualified personnel who have the necessary knowledge and practical experience with electrical equipment and who understand the hazards that can arise when working on this type of equipment.
- Disconnect batteries from outputs and/or follow safety procedures while working on equipment. Batteries may be connected in parallel with the output of the rectifiers. Turning off the rectifiers will not necessarily remove power from the bus.
- Do not disconnect permanent bonding connections unless all power inputs are disconnected.
- Verify that equipment is properly safety earth grounded before connecting power. High leakage currents may be possible.
- Exercise care and follow all safety warnings and practices when servicing this equipment. Hazardous energy and voltages are present in the unit and on the interface cables that can shock or cause serious injury. When equipped with ringer modules, hazardous voltages will be present on the ringer output connectors.
- Use the following precautions in addition to proper job training and safety procedures:
 - Use only properly insulated tools.
 - Remove all metallic objects (key chains, glasses, rings, watches, or other jewelry).
 - Follow Lock Out Tag Out (LOTO) procedures: customer specified, site specific, or general as appropriate. Disconnect all power input before servicing the equipment. Check for multiple power inputs.
 - Wear safety glasses.
 - Follow Personal Protective Equipment requirements: customer specified, site specific, or general as appropriate.
 - Test circuits before touching.
 - Be aware of potential hazards before servicing equipment.
 - Identify exposed hazardous electrical potentials on connectors, wiring, etc.
 - Avoid contacting circuits when removing or replacing covers;
 - Use a personal ESD strap when accessing or removing electronic components.
- Personnel with electronic medical devices need to be aware that proximity to DC power and distribution systems, including batteries and cables, typically found in telecommunications utility rooms, can affect medical electronic devices, such as pacemakers. Effects decrease with distance.

Change History (excludes grammar & clarifications)

Revision	Date	Description of the change
5.0	08/10/2023	Updated as per ABB template



ABB

601 Shiloh Rd.
Plano, TX USA

abbpowerconversion.com

We reserve the right to make technical changes or modify the contents of this document without prior notice. With regard to purchase orders, the agreed particulars shall prevail. ABB does not accept any responsibility whatsoever for potential errors or possible lack of information in this document.

We reserve all rights in this document and in the subject matter and illustrations contained therein. Any reproduction, disclosure to third parties or utilization of its contents – in whole or in parts – is forbidden without prior written consent of ABB.

All rights reserved