

CPS6000 Power System

For systems with rear access AC terminal box.



The shelf is installed with a minimum gap of 3/4 inch below the system to allow proper airflow. Attach the CPS shelf to the frame using a minimum of twelve (six on each side) of the 12-24 screws included with the shelf.

Information – Tools Required

- Wire cutters and strippers
- Heat shrink gun
- Torque wrench (0-240 in-lb / 28 Nm)
- Digital meter, +/- 0.02%
- Screw Drivers (#1 and #2 Phillips)
- Cable crimpers
- 5/16" and 3/8" nut drivers and sockets

Step # 1 – Connect DC Reference (CO) Ground

Use a 1/4" diameter double-hole lug on 5/8" center (Not provided) to ground the chassis as shown in the figure below. Torque connection to 65 in-lbs. The DC reference ground is connected to the return bus as shown below. Use a 3/8" diameter double-hole lug on 1" centers (Not provided).

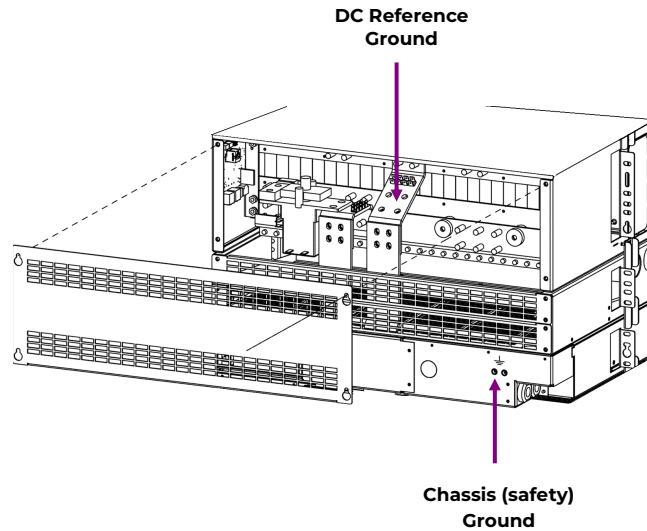

Step # 2 – Connect AC Input cords

Each Rectifier shelf comes equipped with rear access terminal blocks and conduit fittings for ac connection. The AC feeds may be either 110 VAC or 208/220VAC depending on the rectifier type used.

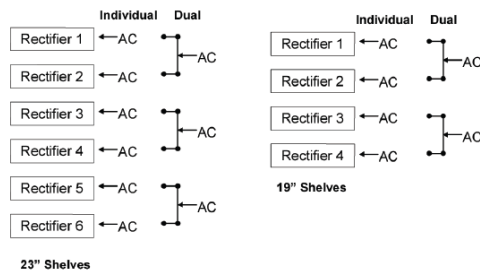

Caution: Ensure ac power is OFF and use appropriate lock-out tag-out procedures before continuing with ac connections.

Caution: When connecting to utility source, ensure all local and national wiring rules are being complied with.

Caution: When routing AC cables ensure cable does not come in contact with sharp or rough surfaces that may damage insulation and cause a short circuit. Make sure cable does not come in contact with any pinch points such as doors.

Step # 3 – Connect DC Output to Loads and Batteries

The figure (right) shows the DC circuit description for the distribution system. The system is equipped with 20 (19" panel) or 26 (23" panel) bullet-style distribution positions. Each of the positions in the distribution panel are selectable between either battery inputs or load outputs.

Breaker sizes up to 250A, TPS fuses to 70A and GMT fuses to 12A are available. DC Connections are made with double hole lugs on 1/4"-20 studs on 5/8" centers. The maximum tongue width for breaker connections is 0.68".

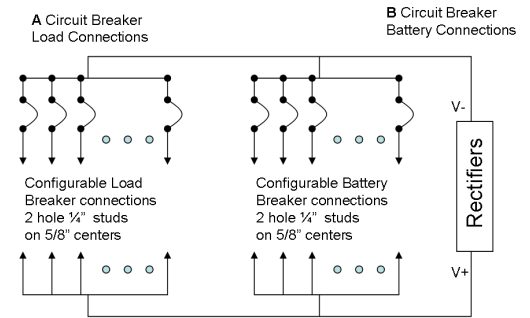

A + B = 20 for 19" shelves or 26 for 23" shelves.

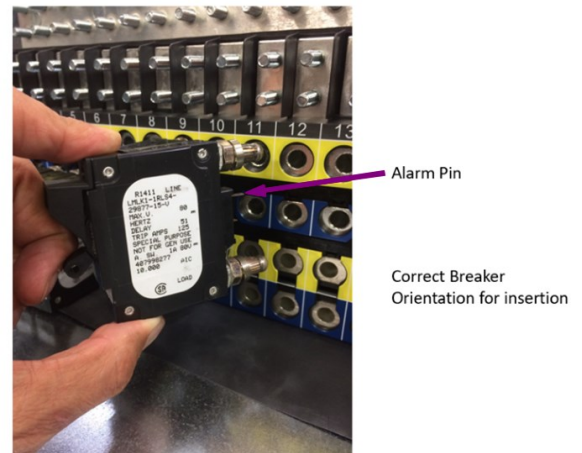
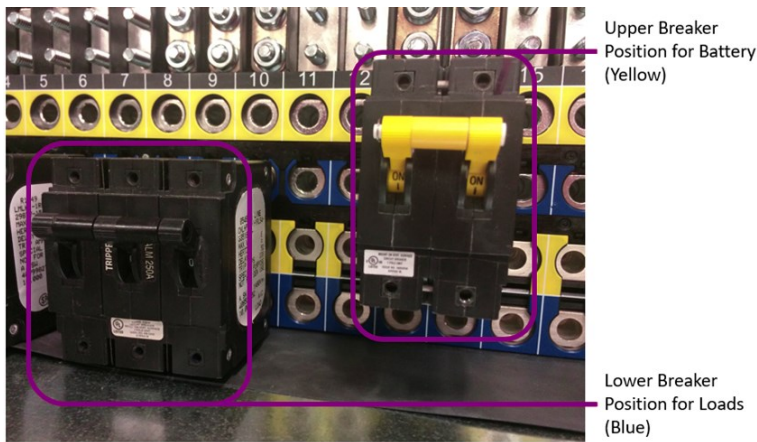

Load and battery cabling, showing multi-pole adapters installed in distribution space

The correct multi-pole adapters must be used with multi-pole breakers

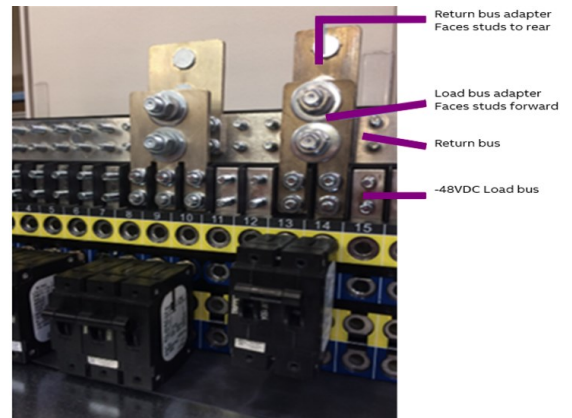

Ordering code	Description	Picture
850021775	2 - pole Adapter bus for 100-150A breakers; used for 3/8" on 1" lugs (order 2 per 3pole breaker to accommodate load and return lugs.)	
850021955	3 - pole Adapter bus for 200-250A breakers; Centered connection (order 2 per 3 pole breaker to accommodate load and return lugs.)	

Step # 4 – Controller Connections

Connect LAN, Office Alarm, Alarm Inputs and Thermal Probes to J5, J4, J3 and J2 respectively as shown right. Special Cables are available for these purposes if required.

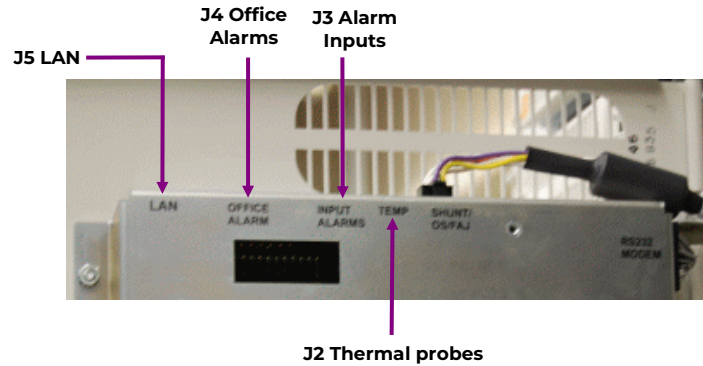

Step # 5 – Rectifier Installation

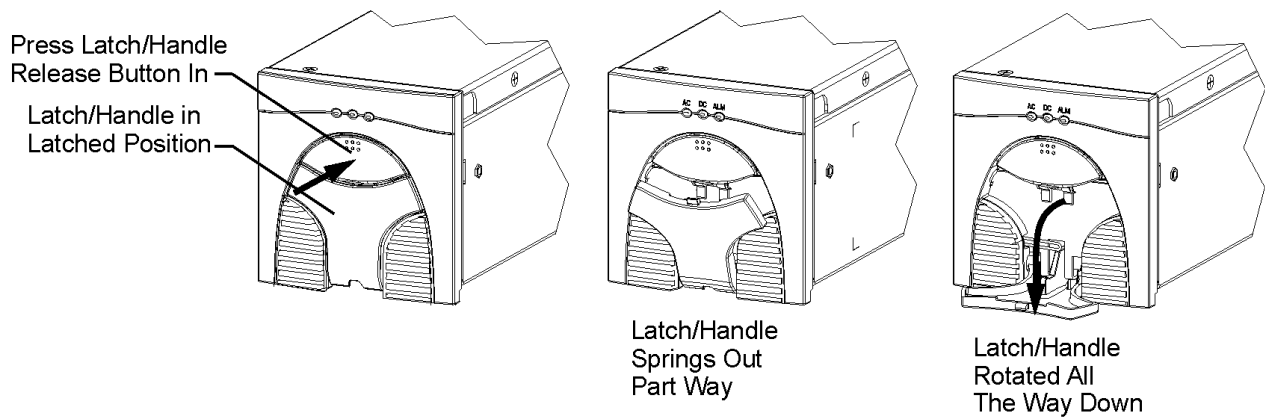

To install a rectifier, remove the rectifier from all of its packing material and unlatch the handle as shown above. Firmly push the rectifier into the rectifier slot until the connector on the rear of the rectifier engages with the connector at the back of the rectifier slot on the CPS shelf. The latch will pop most of the way up when the rectifier is properly seated. Push the latch up into the latched position to complete engagement.

Step # 6 – Initial Start Up

Verify that all AC, DC and Alarm connections are complete and secure. Once this is complete, the AC input breakers may be turned on. If rectifiers have not yet been installed, install rectifiers now as described previously. As each rectifier is installed, the controller automatically identifies the new rectifier and begins communication. If there are no alarms, make any adjustments to the default settings on the controller that are required for this installation. Refer to the Pulsar Plus Product Manual for issues like web pages, craft port and changes to settings. Most functions in software are intuitive by referring to the menu map listed in the detail Manual

Information: Controller Basic Operation

The backlight of the four-line LCD display changes color to reflect the system alarm status as follows:

- Green Normal
- Amber Minor Alarms Present
- Red Major Alarms Active

The up and down arrow keys can be used to adjust screen contrast when the controller is displaying the default screen. The left and right arrow keys are used to navigate the menus and the up and down arrow keys are used to change values when configuring the system. A black box highlighting a menu item indicates that the item has sub-menus. Full configuration details and Menu structure are available in the Product Manual.

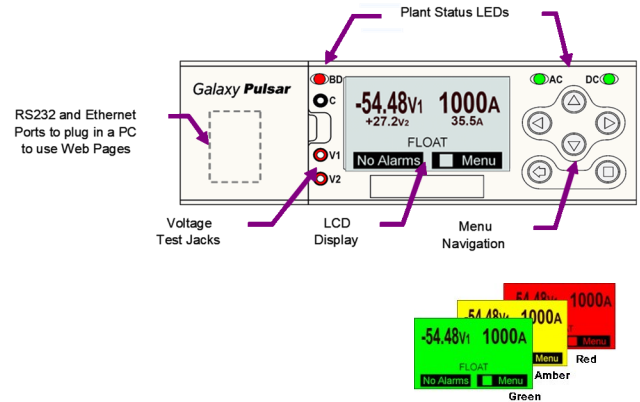

Information: Controller Menu

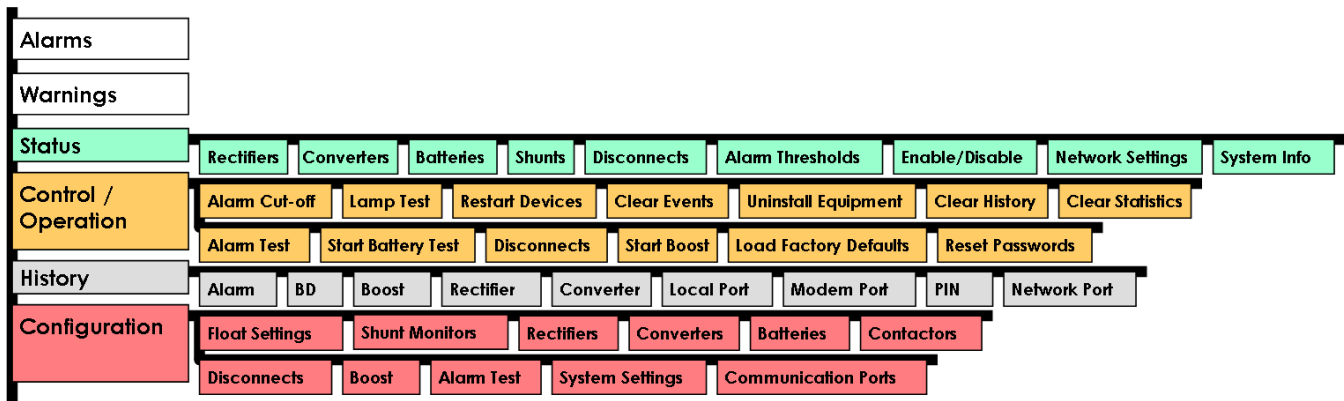

Information: 1 – Wire Battery Temp and Voltage Monitor

Battery Monitoring is accomplished with a “Daisy Chained” series of probes connected to J3. The Probes are used to monitor battery temperature and voltage (ES771 required to monitor voltage). Bolt the Probe under the “-” terminal connector hardware; NOT under the connecting Lug.

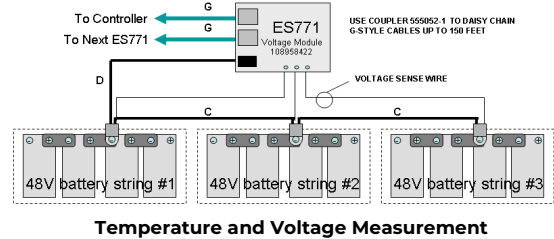
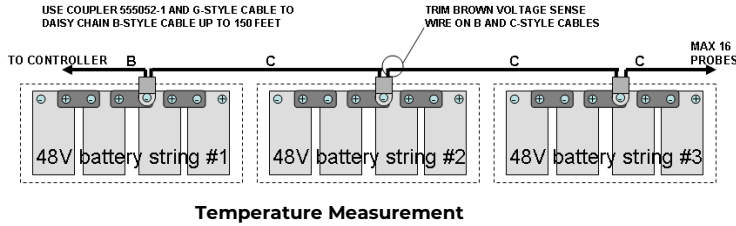

Ordering Codes	Descriptions
CC109142980	QS873A Thermal Probe
CC848817024	B: 10' controller to thermal probe wireset
CC109157434	B: 20' controller to thermal probe wireset
CC848822560	C: 1' thermal probe to thermal probe wireset
848719803	C: 5' thermal probe to thermal probe wireset
CC848822321	C: 10' thermal probe to thermal probe wireset

Ordering Codes	Descriptions
108958422	ES771A Voltage Monitor Card
CC848791517	D: 2 ½' ES771A to probe wireset
CC848797290	D: 6' ES771A to probe wireset
848719829	D: 10' ES771A to probe wireset
CC848791500	G: 4' ES771A to ES771A or controller wireset
848652947	G: 10' ES771A to ES771A or controller wireset

Information: Office Alarm Connections

All standard controller output alarm connections are available from the output connector. Connector J4 provides access to the primary customer alarm output interface. Connector J4 is a 20-pin right angle header with latching capability. Standard color coded cable assemblies are available.

Office Alarm Cables:

Discrete Wire 15ft: CC109157442

Discrete Wire 50ft: CC848817635

Discrete Wire 150ft: CC848817643

Contact technical field support for additional cable options.

	48V Standard	Pin	Color
PCR	Power Critical	1	BL
PCR_C		11	BL-BK
PMJ	Power Major	2	O
PMJC		12	O-BK
PMN	Power Minor	3	G
PMN_C		13	G-BK
R1	Battery on Discharge (BD)	4	BR
R1_C		14	W-BK
R2	AC/Multiple AC Fail (ACF)	5	S
R2_C		15	BK-W
R3	Rectifier Fail (RFA)	6	BL
R3_C		16	BL-R
R4	Very Low Voltage	7	O
R4_C		17	R
R5	Fuse Alarm (External FAJ2)	8	G
R5_C		18	R-G
R6	High Voltage (HV)	9	BR
R6_C		19	R-W
R7	Unassigned (User Configurable)	10	S
R7_C		20	R-BK

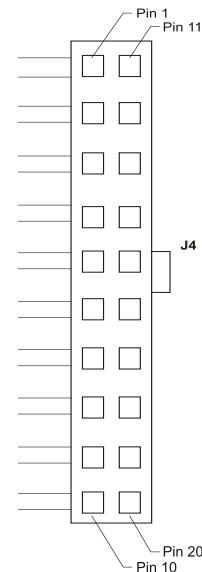

Change History (excludes grammar & clarifications)

Revision	Date	Description of the change
1.0	07/2012	Initial release
2.0	07/11/2023	Updated as per ABB template
2.1	11/08/2023	Updated as per OmniOn template
3.0	01/07/2024	Corrected document name

OmniOn Power Inc.

601 Shiloh Rd.
Plano, TX USA

omnionpower.com

We reserve the right to make technical changes or modify the contents of this document without prior notice. OmniOn Power does not accept any responsibility for errors or lack of information in this document and makes no warranty with respect to and assumes no liability as a result of any use of information in this document.

We reserve all rights in this document and in the subject matter and illustrations contained therein. Any reproduction, disclosure to third parties or utilization of its contents – in whole or in parts – is forbidden without prior written consent of OmniOn Power. This document does not convey license to any patent or any intellectual property right. Copyright© 2023 OmniOn Power Inc. All rights reserved.