

GPS 4848 Galaxy Power System

-48V DC Large Power Plant H569-434



Table of contents

03	Overview
04– 06	Galaxy 595LT TE Rectifiers
07	Cabinet Specification
08	AC Input Specifications
09 – 28	Ordering Information

The industry standard for telecom power, the GPS4848/100 is the first choice to meet dc power requirements of large centralized switching, and Internet Services data centre applications. The GPS provides output capacities up to 20,000A in an integrated multi-cabinet configuration utilizing 3-Phase 3-wire rectifiers operating on commercial 208/220/240Vac or 380/400/480Vac. The Galaxy Millennium II controller provides detailed system management and flexible control of OmniOn and third part equipment.

- Telecom central office, IS data centres and MTSO applications
- Streamlined system control and monitoring
- 20,000 Amp capacity
- Rectifier efficiencies approaching 96%

Bay Options

The system can be deployed in centralized or distributed system architectures. GPS provides industry leading capacity of up to 3080 Amps in a single cabinet which can scale to 20,000 Amps in a multi-cabinet system solution. A single Millennium II controller links all components of the system, while intelligently interacting with the local and remote Ethernet networks.

595 Rectifier

The 595LT-TE rectifier integrates proven technology with superior control features in a compact, cost effective solution. This highly efficient rectifier platform provides unparalleled performance maximizing system investment approaching 96%. The 595LT-TE series offers two modules for use in -48V applications.

Rectifier:

- 595LTA-TE, 220A/48V output @ 480VAC
- 595LTB-TE, 220A/48V output @ 208/240VAC

Galaxy Millennium* II Controller

The Galaxy Millennium II controller combines sophisticated power monitoring and remote management. This flagship controller simplifies operations and maintenance while lowering administrative costs. Remote peripheral modules support over 500 monitoring points for OmniOn or third party devices. Ethernet, SNMP, and TL1 provide integration and surveillance of system-state conditional reporting and capacity management.

Features and Benefits

Reliability

- Delivers decades of service
- High availability architecture
- NEBS level 3 certified

Intelligence

- Industry leading controller features
- Ethernet interface for remote access
- Centralized network management

Investment Protection

- Backward compatibility
- Flexible upgrade options
- Seamless integration with ferro plants

On Time Delivery

- Standard building blocks
- 4 - 6 week availability
- 24/7 technical support

Galaxy 595LT TE Rectifiers

- Provides high power density
- Plug and Play-installation of the rectifier in a shelf connected to a compatible system controller initializes all set up parameters automatically. No adjustments are needed.
- Digital meter, rectifier state and on/off/standby indicators
- Extended service life-parallel operation with automatic load sharing ensures that parallel units are not unduly stressed even when a unit fails or is removed.
- Monitoring/control-the built in microprocessor controls and monitors all critical rectifier functions and communicates with the system controller using the built in Galaxy Protocol serial interface.
- Fail safe performance-hot insertion capabilities allow for rectifier replacement without system shutdown; soft start and inrush current protection prevent nuisance tripping of upstream breakers.



Applications

- Telecommunications Networks
- Digital Subscriber Line (DSL)
- Indoor/Outdoor Wireless
- Routers/Switches
- Fiber in the Loop
- Transmission
- Data Networks
- PBX

Key Features

- Digital load sharing
- Hot pluggable
- Front panel meter
- System State - LED indicators
- High power density
- 3-Phase, 3-wire input
- Compliant to RoHS Directive 2011/65/EU and amended Directive (EU) 2015/863.
- -48V input
- Approaching 96% efficient

Specifications

Input	595LTA TE Rectifier	595LTB TE Rectifier
Voltage Range	320 – 530 Vac	176 – 275 Vac
Input Current (Specified)	20A at 480V 25A at 380V	40A at 208Vac 35A at 240Vac
Rated Maximum	30A	50A
Typical Maximum	22A at 320Vac 19A at 380Vac 15A at 480Vac	41A at 176Vac 36A at 200Vac 33A at 208Vac 30A at 240Vac
Input Frequency	44 – 63Hz	44 – 63Hz
Power Factor	0.99 at >50% to 100% load	0.99 at >50% to 100% load
Efficiency (from 100Adc to 220Adc)	96%	95.5%
Total Harmonic Distortion	<5% from 50 – 100% load	<5% from 50 – 100% load
Output		
Voltage Adjust Range	44-58Vdc float/boost	44-58Vdc float/boost
Voltage Nominal	52Vdc	52Vdc
Regulation (with controller)	±0.5%	±0.5%
Ripple	100mVrms	100mVrms
Output Current	-0°C to 37°C -0°C to 40°C 50°C	NA 220A 200A
Heat Release	54Vdc – 160Adc 54Vdc – 200Adc 54Vdc – 220Adc	270W (920 BTU/hr) 450W (1,550 BTU/hr) 560W (1,930 BTU/hr)
		360W (1,240 BTU/hr) 510W (1,750 BTU/hr) 630W (2,150 BTU/hr)

ENVIRONMENTAL

Operating Temperature	-5°C to +55°C (23°F to 131°F)
Storage Temperature	-40°C to +85°C (-40°F to 185°F)
Humidity	< 95% non-condensing
Altitude	-50 to 4000 meters (Altitudes above 1500 meters, de-rate the temperature by 0.656C per 100 meters)
MECHANICAL	
Length (inch /mm)	18.2/ 470
Width (inch /mm)	10.40/265
Height (inch/mm)	8.25/210
Weight (lb / Kg)	LTA – 37/17 LTB – 33/15

Specifications (Continued)

Safety and Standards Compliance		595LT TE Rectifier
NEBs Level 3	Evaluated by independent NRTL test lab to Telcordia GR63, Issue 3 & GR 1089, Issue 5	
Safety	UL Recognized (US & Canada) and VDE UL 1950, EN60950/IEC950 CSA 234/950 (tested for SELV output)	
RoHS	Compliant to RoHS EU Directive 2002/95/EC; RoHS 5/6	
Electromagnetic Compliance: Emission and Immunity	EN55022 (CISPR22) Radiated/conducted emission Class I EC/EN61000-4-2 ESD levels 3 & 4 IEC/EN61000-4-3 Radiated Immunity. 10V/m IEC/EN61000-4-4 Electrical Fast Transients/Burst, level 4 IEC/EN61000-4-5 Lightning Surge, level 4 FCC Part 15, Class A; GR1089-CORE, Issue 5	

OUTLINE DRAWING

Rectifier Control and Feature Panel

- 3 Position Power Switch
- On and Stand by LED lamps
- Current Display Meter
- Status LED's
 - ALM (red): Thermal/Comm.
 - LIM (yel.): Current Limit
 - FAN ALM (red): Fan Fail
 - BST (yel.): Boost/Equalize mode

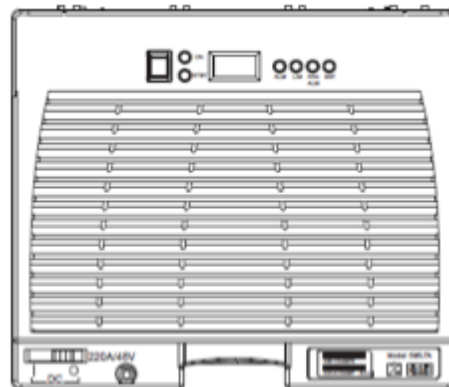
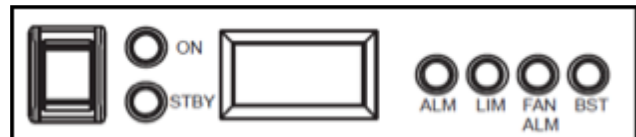

Cabinet Specifications

Mechanical	
Height	84.0 inches (2,134mm)
Width	23.6 inches (600mm)
Depth	23.6 inches (600mm)

Thermal (54Vdc at 220A dc)	595 LTA TE	595 LTB TE
4 Rectifiers	2,240W (7,720 BTU/hr)	2,520W (8,600 BTU/hr)
6 Rectifiers	3,360W (11,580 BTU/hr)	3,780 (12,900 BTU/hr)
8 Rectifiers	4,480W (15,440 BTU/hr)	5,040W (17,200 BTU/hr)
12 Rectifiers	6,720 (23,160 BTU/hr)	7,560 (25,800 BTU/hr)
14 Rectifiers	7,840 (27,020 BTU/hr)	8,820 (30,100 BTU/hr)

Environmental	
Operating Temperature Range	0°C to +45°C (32°F to 113°F)
Operating Relative Humidity	< 95% non-condensing
Storage Temperature Range	-40°C to +85°C (-40°F to 185°F)
EMC	FCC and CISPR22 (EN55032) Class A
Immunity	GR1089, EN55024

Agency Certifications	
UL	Canada/US UL60950/UL1801
EMI/EMC	CISPR Class A conducted and radiated

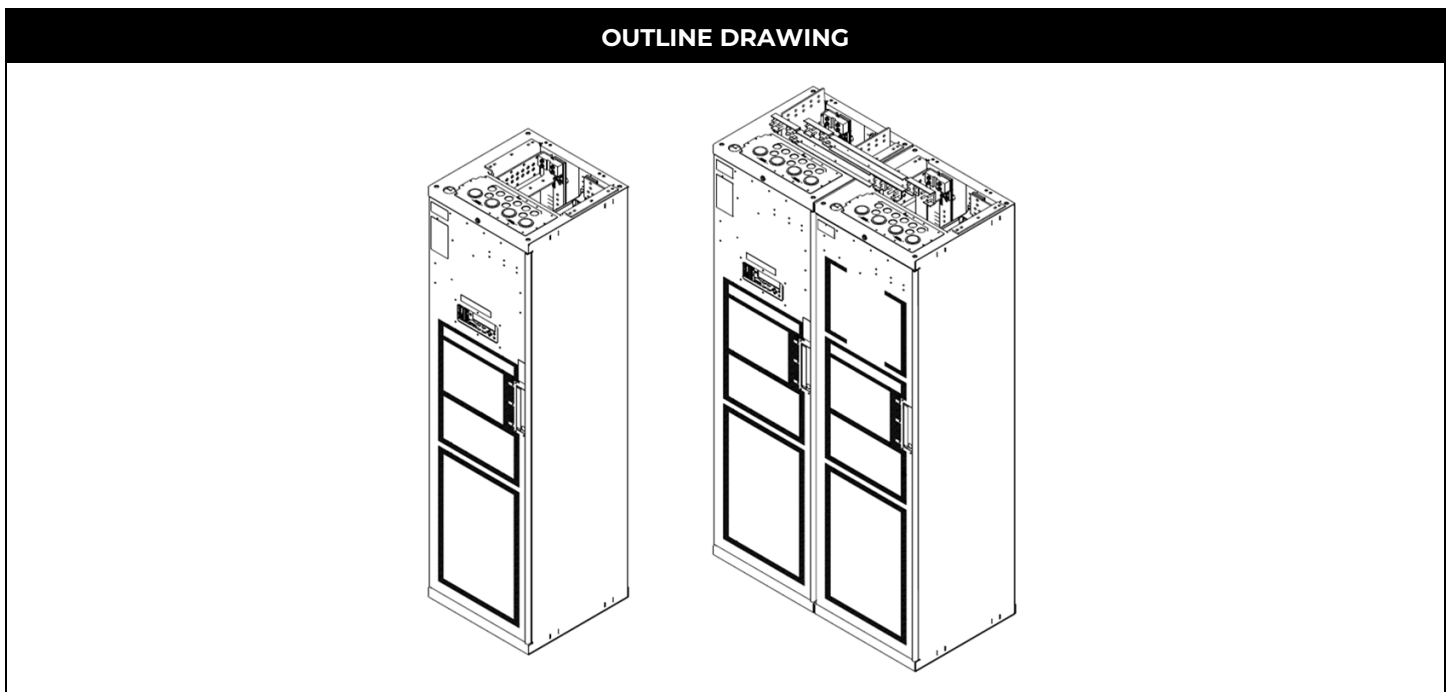

AC Input Specifications

Group Code	# of Rect shelves	# of Rect per CB	Nominal Rect Voltage	Input Current per CB	Circuit Breaker	# of Circuit Breakers	Wire Size at 90C per NEC 310-16	Wires per Conduit	# of Conduits	Minimum Conduit Size
321	3	3	208	104.7	150	2	1/0	3	2	1 1/4
323	3	3	480	44.6	70	2	4	6	1	1 1/4
	3	3	480	44.6	70	2	6	3	2	3/4
325	3	1	208	34.9	50	6	4	9	2	1 1/4
	3	1	208	34.9	50	6	8	3	6	3/4
327	3	1	480	14.9	25	6	8	18	1	1 1/2
	3	1	480	14.9	25	6	10	9	2	3/4
	3	1	480	14.9	25	6	10	3	6	1/2
328	6	1	480	14.9	25	12	8	18	2	1 1/2
	6	1	480	14.9	25	12	8	18	2	1 1/2
	6	1	480	14.9	25	12	10	9	4	3/4
	6	1	480	14.9	25	12	10	9	4	3/4
	6	1	480	14.9	25	12	10	6	6	1/2
329	6	1	208	34.9	50	12	6	6	6	1
	6	1	208	34.9	50	12	4	9	4	1 1/2
332	7	1	480	14.9	25	14	10	6	7	1/2
333	7	1	208	34.9	50	14	6	6	7	1
334	6	3	480	44.6	70	4	4	6	2	1 1/4
	6	3	480	44.6	70	4	6	3	4	3/4
335	6	3	208	104.7	150	4	1/0	3	4	1 1/4
371	3	1	480	14.9	25	6	8	18	1	1 1/2
	3	1	480	14.9	25	6	10	9	2	3/4
	3	1	480	14.9	25	6	10	3	6	1/2
220	4	2	208	69.8	100	2	2	3	2	1
224	4	1	208	34.9	50	4	6	6	2	1
	4	1	208	34.9	50	4	8	3	4	1/2
226	4	1	480	14.9	25	4	10	6	2	1/2
270	4	2	480	29.8	50	2	8	3	2	1/2

Additional Information

Product Documentation

H569434 : Ordering Guide A copy of the appropriate installation manuals below ship with each system.

108994042 : Galaxy Power System 4848/100 with dual rectifier shelf Product Manual

108327362 : Installation Guide for Galaxy Power Systems

Ordering Information – GPS4848 Galaxy Power System

The GPS4848 system can be deployed in centralized or distributed system architectures. GPS provides industry leading capacity of up to 3080 Amps in a single cabinet which can scale to 20,000 Amps in a multi-cabinet system solution. A single Millennium II controller links all components of the system, while intelligently interacting with the local and remote Ethernet networks. Designed for either internal input AC breakers or terminal strip terminations, rectifier shelves can be spread across multiple bays as the system grows. For greater flexibility and working space, the 4848 may be equipped with a larger 36 inch wide distribution bay to accommodate large cable termination and egress.

Key Features

- Telecom central office, IS data centres and MTSO applications
- Streamlined system control and monitoring
- 20,000 Amp capacity
- Rectifier efficiencies approaching 96%

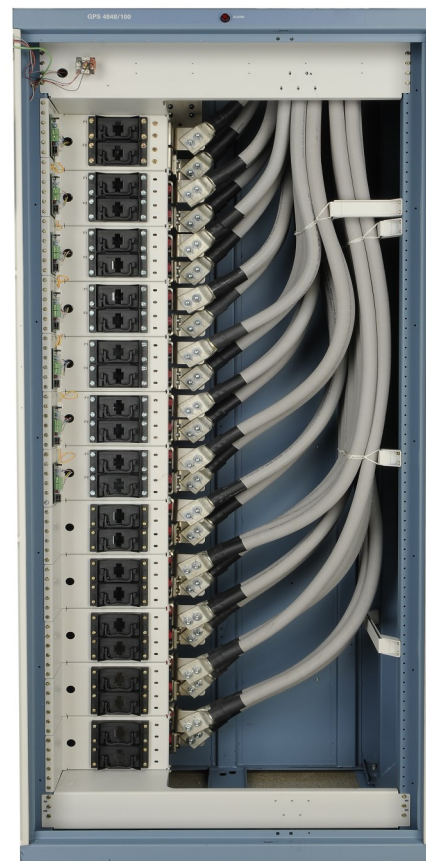

Wide Bay Wired with 750MCM Cable

Step 1: Select the Bays

-48V Distributed Architecture Primary (Control) Bays					
Output	Ordering Code	Model	AC Input		Picture
	108997516	GPS 4848 Distributed Architecture Full Height Control Bay, Millennium II controller, bulk feed 480V AC input for up to six 595LTA rectifiers, 1500A battery shunt H569434 G-1, 19, 323, 32			
			2 AC Feeds 6 Circuit Breakers		Vertical Distribution Available: 36"
	108997425	GPS 4848 Distributed Architecture Full Height Control Bay, Millennium II controller, terminal strip feed 480V AC input for upto six 595LTA rectifiers, 1500A battery shunt H569434 G-1, 19, 327, 32			
			6 AC Feeds Terminal Strip		Vertical Distribution Available: 45"
	108997524	GPS 4848 Distributed Architecture Full Height Control Bay, Millennium II controller, bulk feed 480V AC input for up to four 595LTA rectifiers, 3000A battery shunt H569-434 G-1, 19, 322, 32A			
			1 AC Feed 4 Circuit Breakers		Vertical Distribution Available: 54"
	108997482	GPS 4848 Distributed Architecture Full Height Control Bay, Millennium II controller, terminal strip feed 480V AC input for upto four 595LTA rectifiers, 3000A battery shunt H569434 G-1, 19, 326, 32A			
			4 AC Feeds Terminal Strip		Vertical Distribution Available: 54"
	CC109126182	GPS 4848 Distributed Architecture Full Height Control Bay, Millennium II controller, terminal strip feed 480V AC input for upto eight 595LTA rectifiers, 3000A battery shunt H596-434 G-1, 19, 330, 32A			
			8 AC Feeds Terminal Strip		Vertical Distribution Available: 54"

Step 1: Select the Bays-Distributed Architecture (continued)

-48V Distributed Architecture Primary (Control) Bays					
Output	Ordering Code	Model	AC Input		Picture
	CC109145942	GPS 4848 Distributed Architecture Full Height Control Bay, Millennium II controller, bulk feed 208-240V AC input for up to six 595LTB rectifiers, 1500A battery shunt H569434 G-1, 19, 321, 32			Vertical Distribution Available: 36"
			2 AC Feeds 6 Circuit Breakers		
	CC109150067	GPS 4848 Distributed Architecture Full Height Control Bay, Millennium II controller, terminal strip feed 208-240V AC input for up to six 595LTB rectifiers, 1500A battery shunt H569434 G-1, 19, 325, 32			Vertical Distribution Available: 45"
			6 AC Feeds Terminal Strip		
	CC109154571	GPS 4848 Distributed Architecture Full Height Control Bay, Millennium II controller, bulk feed 208-240V AC input for up to four 595LTB rectifiers, 1500A battery shunt H569-434 G-1, 19, 320, 32			Vertical Distribution Available: 51"
			2 AC Feed 4 Circuit Breakers		
	CC109154588	GPS 4848 Distributed Architecture Full Height Control Bay, Millennium II controller, terminal strip feed 208-240V AC input for up to four 595LTB rectifiers, 1500A battery shunt H569-434 G-1, 19, 324, 32			Vertical Distribution Available: 54"
			4 AC Feeds Terminal Strip		
	CC109128484	GPS 4848 Distributed Architecture Full Height Control Bay, Millennium II controller, terminal strip feed 208-240V AC input for up to eight 595LTB rectifiers, 3000A battery shunt H596-434 G-1, 19, 331, 32A			Vertical Distribution Available: 54"
			8 AC Feeds Terminal Strip		

Step 1: Select the Bays-Distributed Architecture (continued)

-48V Distributed Architecture Primary (Control) Bays					
Output	Ordering Code	Model	AC Input		Picture
	108997508	GPS 4848 Distributed Architecture Full Height Supplement Bay, no controller, bulk feed 480V AC input for up to six 595LTA rectifiers, 3000A battery shunt H569434 G-1, 18D, 323, 32A			
			2 AC Feeds 6 Circuit Breakers		Vertical Distribution Available: 36"
	108997433	GPS 4848 Distributed Architecture Full Height Supplement Bay, no controller, terminal strip feed 480V AC input for upto six 595LTA rectifiers, 1500A battery shunt H569434 G-1, 18D, 327, 32			
			6 AC Feeds Terminal Strip		Vertical Distribution Available: 45"
	108997532	GPS 4848 Distributed Architecture Full Height Supplement Bay, no controller, bulk feed 480V AC input for up to four 595LTA rectifiers, 3000A battery shunt H569-434 G-1, 18D, 322, 32A			
			1 AC Feed 4 Circuit Breakers		Vertical Distribution Available: 54"
	108997490	GPS 4848 Distributed Architecture Full Height Supplement Bay, no controller, terminal strip feed 480V AC input for upto four 595LTA rectifiers, 3000A battery shunt H569-434 G-1, 18D, 326, 32A			
			4 AC Feeds Terminal Strip		Vertical Distribution Available: 54"
	CC109126174	GPS 4848 Distributed Architecture Full Height Supplement Bay, no controller, terminal strip feed 480V AC input for upto eight 595LTA rectifiers, 3000A battery shunt H596-434 G-1, 18D, 330, 32A			
			8 AC Feeds Terminal Strip		Vertical Distribution Available: 36"

Step 1: Select the Bays – Distributed Architecture (continued)

-48V Distributed Architecture Supplementary Bays					
Output	Ordering Code	Model	AC Input		Picture
	CC109151148	GPS 4848 Distributed Architecture Full Height Supplemental Bay, no controller, bulk feed 208-240V AC input for up to four 595LTB rectifiers, 1500A battery shunt H569-434 G-1, 18D, 320, 32			
			2 AC Feeds 4 Circuit Breakers		Vertical Distribution Available: 51"
	CC109150075	GPS 4848 Distributed Architecture Full Height Supplemental Bay, no controller, terminal strip feed 208-240V AC input for upto four 595LTB rectifiers, 1500A battery shunt H569-434 G-1, 18D, 324, 32			
			4 AC Feeds Terminal Strip		Vertical Distribution Available: 54"
	CC109152690	GPS 4848 Distributed Architecture Full Height Supplemental Bay, no controller, bulk feed 208-240V AC input for up to six 595LTB rectifiers, 1500A battery shunt H569434 G-1, 18D, 321, 32			
			2 AC Feeds 6 Circuit Breakers		Vertical Distribution Available: 36"
	CC109147955	GPS 4848 Distributed Architecture Full Height Supplemental Bay, no controller, terminal strip feed 208-240V AC input for upto six 595LTB rectifiers, 1500A battery shunt H569434 G-1, 18D, 325, 32			
			6 AC Feeds Terminal Strip		Vertical Distribution Available: 45"
	CC109128476	GPS 4848 Distributed Architecture Full Height Supplemental Bay, no controller, terminal strip feed 208-240V AC input for upto eight 595LTB rectifiers, 3000A battery shunt H596-434 G-1, 18D, 331, 32A			
			8 AC Feeds Terminal Strip		Vertical Distribution Available: 36"

Step 1: Select the Bays – Centralized Architecture (continued)

-48V Centralized Architecture Primary (Control) Bays					
Output	Ordering Code	Model	AC Input		Picture
	108994406	GPS 4848 Centralized Architecture Full Height Control Bay, Millennium II controller, bulk feed 480V AC input for up to twelve 595LTA rectifiers, battery shunt H569434 G2, 19, 334, 33			Rectifier Only Bay
			4 AC Feeds 12 Circuit Breakers		
	108994380	GPS 4848 Centralized Architecture Full Height Control Bay, Millennium II controller, terminal strip feed 480V AC input for upto twelve 595LTA rectifiers, battery shunt H569434 G2, 19, 328, 33			Rectifier Only Bay
			12 AC Feeds Terminal Strip		
	CC109134235	GPS 4848 Centralized Architecture Full Height Control Bay, Millennium II controller, bulk feed for 208-240V AC input for upto twelve 595LTB rectifiers H569434 G2, 19, 335, 33			Rectifier Only Bay
			4 AC Feeds 12 Circuit Breakers		
	CC109145777	GPS 4848 Centralized Architecture Full Height Control Bay, Millennium II controller, terminal strip feed 208-240V AC input for up to twelve 595LTB rectifiers H569434 G2, 19, 329, 33			Rectifier Only Bay
			12 AC Feeds Terminal Strip		
	108982752	GPS 4848 4800 Amp Centralized Architecture Full Height Control Bay, Millennium II controller, distribution only H569-434 G2, 16, 29, 33	Distribution Only Bay		
					Vertical Distribution Space: 72"
	CC109167607	GPS 4848 4800 Amp Centralized Architecture Full Height Control WIDE Bay, distribution only Vertical Distribution Space: 72.0" with Controller H569434 G2, 19, 430, 33	Distribution Only Bay		
					Vertical Distribution Space: 72"

Step 1: Select the Bays – Centralized Architecture (continued)

-48V Centralized Architecture Supplementary Bays					
Output	Ordering Code	Model	AC Input		Picture
	108993275	GPS 4848 Centralized Architecture Full Height Supplemental Rectifier Only Bay, no controller, bulk feed 480V AC input for upto twelve 595LTA rectifiers H569-434 G2, 18C, 334, 33			
	CC109133006	GPS 4848 Centralized Architecture Full Height Supplemental Rectifier Only Bay, no controller, terminal strip feed 480V AC input for up to twelve 595LTA rectifiers H569-434 G2, 18C, 328, 33			
	108993283	GPS 4848 Centralized Architecture Full Height Supplemental Rectifier Only Bay, no controller, terminal strip 480V AC input for up to fourteen 595LTA rectifiers H569-434 G2, 18C, 332, 33			
	CC109134227	GPS 4848 Centralized Architecture Full Height Supplemental Rectifier Only Bay, no controller, bulk feed 208-240V AC input for up to twelve 595LTB rectifiers H569-434 G2, 18C, 335, 33			
	CC109144333	GPS 4848 Centralized Architecture Full Height Supplemental Rectifier Only Bay, no controller, terminal strip feed 208-240VAC input for up to twelve 595LTB rectifiers H569-434 G2, 18C, 329, 33			
	CC109136660	GPS 4848 Centralized Architecture Full Height Supplemental Rectifier Only Bay, no controller, terminal strip feed 208-240VAC input for up to fourteen 595LTB rectifiers H569-434 G2, 18C, 333, 33			





Step 1: Select the Bays – Centralized Architecture (continued)

-48V Centralized Architecture Supplementary Bays					
Output	Ordering Code	Model	AC Input		Picture
	108873415	GPS 4848 4800 Amp Centralized Architecture Full Height Supplemental Bay, distribution only , no controller H569434 G2, 12, 29, 33	Distribution Only Bay		
					Vertical Distribution Space: 72"
	CC109167615	GPS 4848 4800 Amp Centralized Architecture Full Height Supplemental WIDE Bay, distribution only , no controller (7'H x 36"W 24"D) H569434 G2, 18C, 430, 33	Distribution Only Bay		
					Vertical Distribution Space: 72"
Bottom Feed Solutions (bays to be installed in pairs)					
	150034119	GPS 4848 Centralized Architecture Full Height Control Bay, Distribution only, Millennium II controller. Compatible with 150034120 only H569434 G2, G19, G431	Bottom Feed, Distribution Only Bay		
	150034120	GPS 4848 Centralized Architecture Full Height Supplemental Bay, Rectifiers only, no controller, bulk feed 480V AC input for up to twelve 595LTA rectifiers, battery shunt. Compatible with 150034119 or 150034121 only H569434 G2, G18E, G334B, G33			
			4 AC Feeds 12 Circuit Breakers		
	150034121	GPS 4848 Centralized Architecture Full Height Distribution only, No controller. Used as growth bay when 150034119 and 150034120 are already in place. Should be combined with 150034120 only H569434 G2, 18C, 431	Bottom Feed, Distribution Only Bay		

Note: All supplemental bays include the interconnect bus bars to connect to an adjacent bay

Additional Kits		
Ordering Code	Model	
850019233	Bus Bar Extender	Provides 16 return terminations

Step 2: Select Rectifier

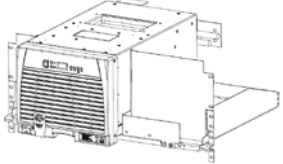
Rectifiers			
Output	Ordering Code	Model	Picture
 220A	108979238	220 Amp, 48VDC output, 480VAC 3 Ph input Rectifier, 96% efficient 595LTA TE	
 220A	108990405	220 Amp, 48VDC output, 208 -240 VAC 3 Ph input Rectifier, approaching 96% efficient 595LTB TE	
	108994686	595LT filler bracket and keying kit for LT rectifier when used with single rectifier shelf	
	848693586	Spare Rectifier Fan Assembly for non-TE rectifiers	
	CC848880914	Spare Rectifier Fan Assembly for TE rectifiers	





Step 3: Select Field Installed Distribution Panels

Field Installed North American Breaker Panels					
Ordering Code	Group Code	Panel Description	Vertical Space (in.)	Internal Return Bars (Dist Arch Only)	Group Code
108971474	G43A	6 Position 125A-800A Circuit Breaker Panel	12	108908070	G43
108971318	G42A	3 Position 125A-600A Circuit Breaker Panel	6	108908070	G42
108971417	G48B	5 Position 125A-800A Circuit Breaker Panel	9	108908070	G48
108971532	G96A	10 Position 3A-100A Bullet Breaker Panel	6	108908104	G96
108971680	G97A	14 Position 3A-200A Bullet Breaker Panel	6	108908104	G97
108987678	G98B	22 Position 3A-200A Bullet Breaker Panel	9	108908104	G98B
Field North American Fuse Panels					
108970872	G52A	10 Position 3A-60A TPS Fuse Panel	6	108908070	G52
108986746	G54A	5 Position 70A-225A TPL-B Fuse Panel	9	108908070	G54
CC109133113	G53A	2 Position 70A-600A TPL Fuse Panel	6	108908104	G53
108985235		6 position 1A-15A GMT Fuse Panel	0	NA	NA
108908278	Low Voltage Load Disconnect Option				
108908070	Return Bus for panels in like shaded lines				
108908104	Return Bus for panels in like shades lines				





Distribution Panels with Ground Return Included					
Ordering Code	Group Code	Description	Vertical Space (in.)		
108971466	G43	6 Position 125A-800A Circuit Breaker Panel	12		
108971292	G42	3 Position 125A-600A Circuit Breaker Panel	6		
108971409	G48	5 Position 125A-800A Circuit Breaker Panel	9		
CC109133105	G59	2 Position 70A-600A Fuse Panel	6		
408472322		Fuse Holder for 70-250A fuses in G59			
108986738	G54	5 Position 70A-225A Fuse Panel	9		
108971524	G96	10 Position 3A-100A Bullet Breaker Panel	6		
108971672	G97	14 Position 3A-100A Bullet Breaker Panel	6		
108987686	G98	22 Position 3A-200A Bullet Breaker Panel	9		
108985235	G58	6 Position GMT Holder up to 15A	0		

Step 4: Select Distribution Component

Note: Plug in, and bolt in distribution components are listed below. These must be selected to match the distribution panels selected in Step 3.

Bullet Style Load Circuit Breakers				
Ordering Code	Amperage	CB Positions	Min Wire Gauge	Photo
407998137	3	1	10	
407998145	5	1	10	
407998152	10	1	10	
407998160	15	1	10	
407998178	16	1	10	
407998186	20	1	10	
407998194	25	1	10	
407998202	30	1	10	
408213486	40	1	8	
407998210	45	1	8	
407998228	50	1	6	
407998236	60	1	6	
407998244	70	1	2	
407998251	80	1	2	
407998269	90	1	2	
407998277	100	1	2	
CC848808551	100	2	2	
408185353	125	2	2	
408185346	150	2	1/0	
408564941	200	3	2/0	
CC408573975	225	3	4/0	
408535752	250	3	4/0	
848631479	2-pole adapter bus kit (includes bus for 1/4" hole lug on 5/8" centers and hardware), order one per breaker			
848745662	3-pole adapter bus kit (includes bus for 5/16" hole lug on 1" centers and hardware), order one per breaker			

Step 4: Select Distribution Component (Continued)

Large Circuit Breaker Kits				
Ordering Code	Amperage	CB Positions	Min Wire Gauge	Photo
108908187	125	1	2	
108908179	150	1	1/0	
108908195	175	1	2/0	
108908203	225	1	4/0	
108908211	300	2	2 x 4/0	
108908237	400	2	2 x 4/0	
108908229	500	3	3 x 4/0	
108908252	600	3	3 x 4/0	
108984782	800	4	4 x 4/0	

Large TPL Fuses				
Ordering Code	Amperage	Max # wires per	Min Wire Gauge	Photo
408472322	(Optional) 70-250A Fuse Holder Head for applications using <251A fuses in GP59 panel.			
402328926	0.18A Alarm Fuse			
406794776	70	3	6	
408239648	80	3	4	
406794784	100	3	2	
406925685	125	3	2	
406794792	150	3	1/0	
406794818	200	3	4/0	
406794982	225	3	4/0	
406794842	250	3	4/0	
406794867	300	3	2 x 4/0	
406794875	400	3	2 x 4/0	
406794883	500	3	2 x 4/0	
406794891	600	3	3 x 4/0	

Step 4: Select Distribution Component (Continued)

Bullet Style Fuse Holder and TPS Fuses					
Ordering Code	Amperage	WP-92461 List	Min Wire Gauge	Photo	
406700567	3	100	10		
406700583	5	101	10		
406700591	6	102	10		
406700609	10	103	10		
406700617	15	104	10		
406700625	20	105	10		
406700633	25	106	10		
406700641	30	107	10		
406700658	40	108	10		
406700674	50	109	8		
406700682	60	110	6		
406700690	70	111	6		
402328926	0.18 Alarm Fuse				
408548944	Bullet Fuse Holder, TFD-101-011-09 (Alarms on Blown Fuse or Fuse Head Removal)				
CC408617410	Bullet Fuse Holder, TFD-101-011-10 (Alarms on Blown Fuse Only)				
GMT Fuses					
405006222	0.25A				
3150439	0.5A				
405673146	1.33A				
405181983	2A				
406976985	3A				
406159061	5A				
405725433	7.5A				
406159236	10A				
406473959	15A				
408515823	Fuse Puller				

Step 5: Select Remote Peripheral Monitoring Options (Millennium 2 Controller only)

Ordering Code	Description			Photo
	Modules	# Inputs	# Temp	
108469461	J85501G1L21 RPM Shunt Monitoring	6	1	
108469479	J85501G1L22 RPM Voltage 0-200VDC	6	1	
108469495	J85501G1L23 RPM Transducers (221J)	6	1	
108298431	J85501G1L24 RPM Voltage 0-3VDC	6	1	
108298498	J85501G1L25 RPM Voltage 0-16VDC	6	1	
108469503	J85501G1L26 RPM Voltage 0-70VDC	6	1	
108298449	J85501G1L27 RPM Binary (222A)	6	1	
108483538	J85501G1L28 RPM Temperature (223T)	0	7	
108298456	J85501G1L9 RPM Control Relay (214A)	3	0	





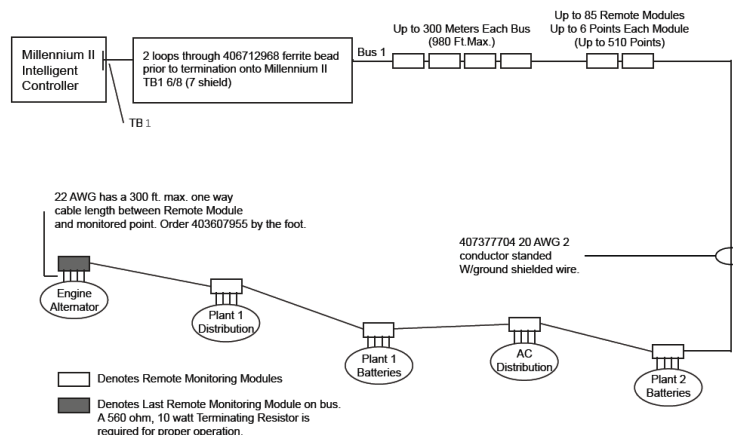

Supporting Material

407377704	Connecting Cable for RPMs (Order by foot)	
848535332	Blue panel for mounting 6 modules above a GPS cabinet	
848412367	White panel for mounting 6 modules in a 23-inch frame inside	
847307410	12' Cable to be used with Temperature Probes	
847917879	1/2" Diameter Ring Terminal Temperature Probe (Cable Required)	
848528881	5/16" Diameter Ring Terminal Temperature Probe (Cable Required)	
405298308	Termination Resistor (1 per bus)	
406712968	Ferrite Bead (1 per bus)	
403607955	Monitor Channel cable KS13385 22AWG stranded pair, R&Bk (order by the foot)	
108984477	23" grey panel, 6 RPM mounting panel for Lorain plants	

Millennium Remote Monitoring



Step 6: Select Optional AC Monitoring Equipment (Millennium 2 Controller only)

AC Monitoring Options		
Ordering Code	Description	Photo
Configured Panels		
CC408646005	3P/3W 208/240V Line to Line, 10x12x14 box provides current, voltage, and power	
CC408646046	3P/3W 480V Line to Line, 10x12x14 box provides current, voltage, and power	
CC408646054	3P/4W 208V Line to Neutral, 10x12x14 box provides current, voltage, and power	
Transducers		
CC408645808	1-phase AC Current Transducer (Built-in CT; 150A max current; 350 kcmil max conductor size)	
CC408645816	1-phase AC Voltage Transducer 120V	
CC408645824	1-phase AC Voltage Transducer 208/240V	
CC408644537	3-phase AC Voltage Transducer 208/240V Line to Line	
CC408645741	3-phase AC Voltage Transducer 208/240V Line to Neutral (120V)	
CC408645832	3-phase AC Voltage Transducer 480V Line to Line	
CC408645840	3-phase AC Current Transducer	
Current Transformers (Required for configured panels and current transducers)		
CC408645857	Current Transformer, 200A primary, 5A secondary, 4 in inside diameter	
408524862	Current Transformer, 400A primary, 5A secondary, 4 in inside diameter	
CC408645865	Current Transformer, 600A primary, 5A secondary, 6 in inside diameter	
CC408645873	Current Transformer, 800A primary, 5A secondary, 6 in inside diameter	
CC408645881	Current Transformer, 1000A primary, 5A secondary, 8 in inside diameter	
CC408645898	Current Transformer, 1200A primary, 5A secondary, 8 in inside diameter	
Miscellaneous		
CC408645907	Barrier terminal block to extend the CT secondary leads beyond their 12 ft factory length. Use 12 AWG THHN wire in conduit.	
CC408645915	Bud Industries Wall Box (12H x 10W x 8D) w/captive screw cover & internal mounting panel. For mounting transducers	

Step 7: Select Battery Termination Options

Order optional termination bar if standard 8 positions may be exceeded	
Ordering Code	Description
850019233	Optional bus bar that provides 16 output terminations. (one required per cabinet)
848385878	Optional adapter that allows two lugs to be stacked and connected at one location. (Provides one adapter)

Step 8: Select Distributed Return Bus Bars

Standard Architecture 600mm Bays		
Ordering Code	Description	
CC848805160	External Return Bus Kit for Mounting on Distributed Architecture Cabinets, 1 per cabinet, rated at 1800 Amps	H569434G13

Only required if internal return bus bars were not ordered. The external return bus kit is an alternative to internal return buses when many large cables are required. Please contact OmniOn for additional options for external return bus bars.

22 SETS OF 3/8 HOLES ON INCH CENTERS FOR 750KCMIL CABLE
7 SETS OF 1/4 INCH HOLES ON 5/8 INCH CENTERS

CC848805160 EXTERNAL RETURN BUS KIT FOR MOUNTING AN DISTRIBUTED ARCHITECTURE CABINETS
THIS KIT IS AN ALTECNATIVE TO INTERNAL RETUEN BUSES WHEN MANY LARGE CABLE ARE REQUIRED

Step 9: Select Centralized Return Bus Bars

Centralized Architecture	
Ordering Code	Description
108298472	ED8301950G9 2600A Ground Bar arranged for mounting on auxiliary framing, or 20 or 25 inch ladder-type cable rack
109006080	ED8301950G11 2600A Ground Bar for stacking with a Group 9, Maximum of 2 can be stacked
108662933	ED8301950G9,2-11 Commonly ordered configuration containing 3 stacked 2600A ground bars

Please see ED83019-50 Drawing, or contact OmniOn, for more ground bar options.

ED83019-50 Outline Drawing for the main bus bar in Groups 9 and 11 (28.62 inches long by 6.00 inches wide)

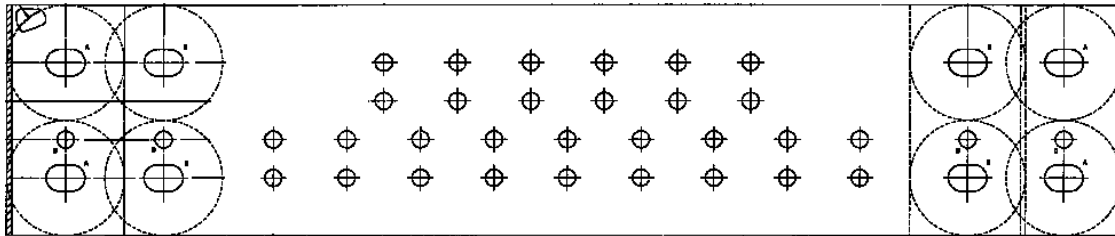

ED83019-50 Outline Drawing for stacking two Group 11's with a Group 9 (Height of 4.5 inches per stack)

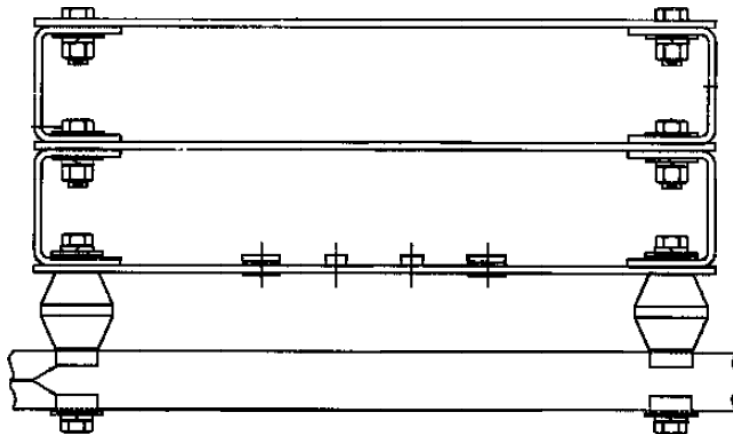

Centralized Architecture	
Ordering Code	Description
105579163	5200A Ground Bar arranged for mounting on auxiliary framing, or 20 or 25 inch ladder-type cable rack

Please see 105579163 Drawing, or contact GE, for more ground bar options of this style.

Outline Drawing for 105579163 bus bar (72.0 in long by 6.00 in wide)

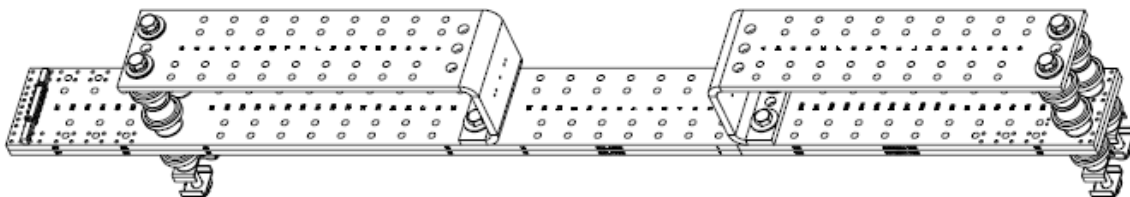

Step10: Select Chandelier Bus Bar (Centralized Architecture)

Centralized Architecture	
Ordering Code	Description
601412273	J85504A1L5 1,200 Amp Chandelier Bus Bar Assembly, Shunt Ordered Separately
848734851	J85504A1LG Growth busbars to List 5 for a 2,600 Amp Capacity
601412265	J85504A1L15 2,600 Amp Chandelier Bus Bar Assembly, Shunt Ordered Separately
601412257	J85504A1LQ Growth busbars to List 15 for a 5,200 Amp Capacity
601978323	J85504A1L20 5,200 Amp Chandelier Bus Bar Assembly, Shunt Ordered Separately
847627650	50mV Shunt with 800 Amp Capacity
846799906	50mV Shunt with 1200 Amp Capacity
846799922	J85504A1LF 50mV Shunt with 2600 Amp Capacity
846799963	50mV Shunt with 4000 Amp Capacity
846799989	J85504A1LP 50mV Shunt with 6000 Amp Capacity
848656294	ED8301950G23 10,000 Amp Chandelier Bus Bar Assembly, Shunt Included
846799948	50mV Shunt with 2600 Amp Capacity
109008532	2600A Upgrade to Main Plant Chandelier

Please see contact OmniOn for more Chandelier options.

J85504A-1 List 15 and Q Front View Outline Drawing Vertical Busbars J85504A-1 List 20 Horizontal Bus Bars

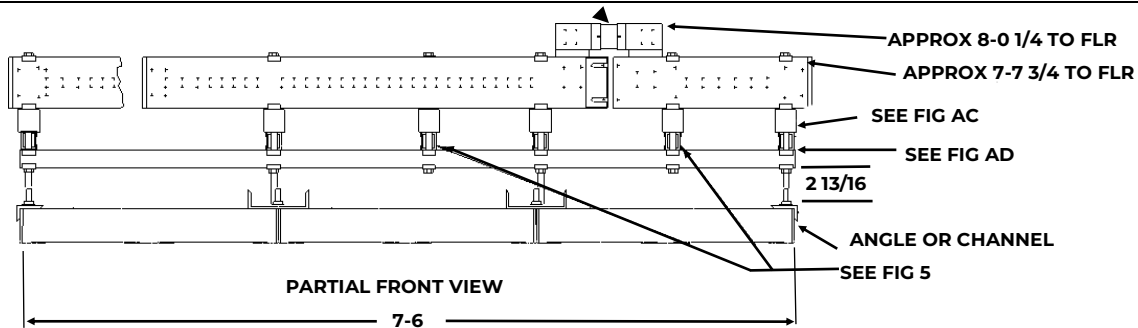

ED83019-50 Group 23 Outline Drawing (Busbar is 72.00 inches long by 8.00 inches wide) Horizontal Busbars

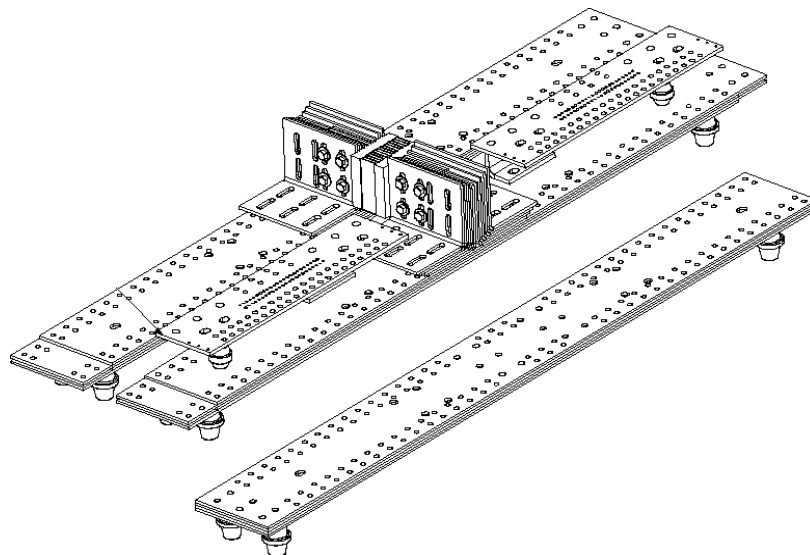

Step 11: Select Optional Horizontal Return Bus Bar System (Centralized Architecture)

Standard Architecture 600mm Bays		
Ordering Code	Description	Picture
CC109170180	Horizontal External Bus Bars Horizontal Rectifier Bay, Rated at 5000Amps, 1 per rectifier bay, Standard Width	
CC109170197	Horizontal External Bus Bars Horizontal Distribution Bay (WIDE), Rated at 5000 Amps, 1 per bay	
CC109170511	Horizontal External Bus Bars Horizontal Distribution Bay (Std), Rated at 5000 Amps, 1 per bay	
<p>This modular external return bus kit is an alternative to standard external or internal return buses. It allows for modular growth of the bars from bay to bay. The bar is designed to accept both small and large cable terminations to support many varying conditions. Please contact OmniOn for additional options for external return bus bars.</p>		

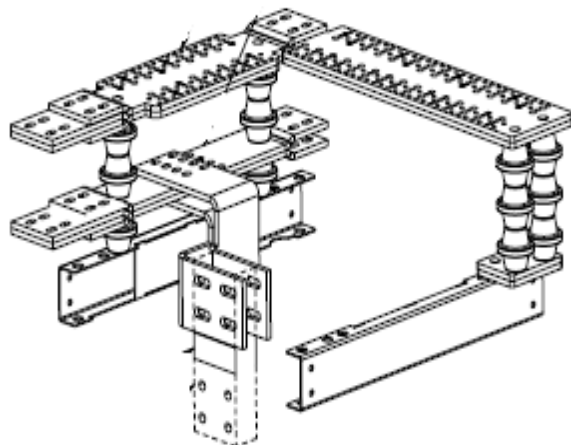

Standard Bay

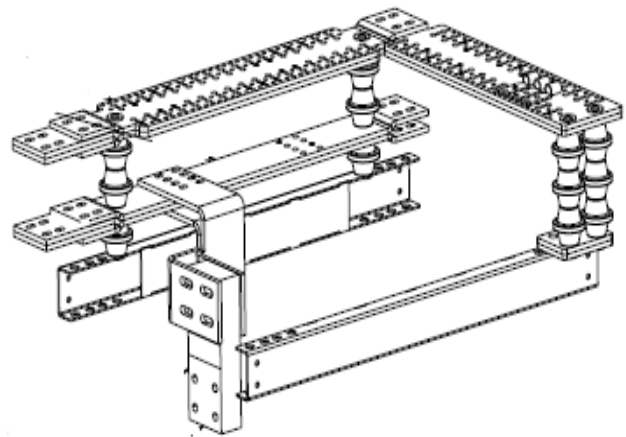

Wide Bay

Horizontal Modular Distribution Bay Overhead Bus

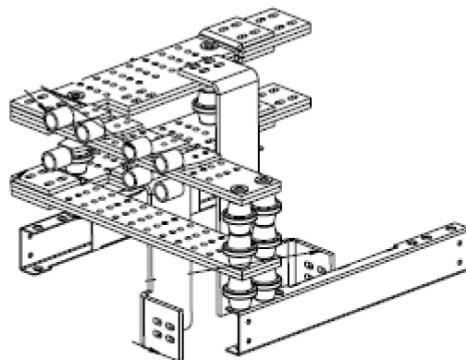

Horizontal Modular Rectifier Bay Overhead Bus

Step 12: Select Optional Vertical Return Bus Bar System (Centralized Architecture)

Standard Architecture 600mm Bays		
Ordering Code	Description	Picture
CC109170404	Vertical External Bus Bars Rectifier Bay Rated at 5000Amps,1 per rectifier bay, Standard Width	
CC109170206	Vertical External Bus Bars Rectifier Bay Rated at 10000Amps,1 per rectifier bay, Standard Width	
CC109170412	Vertical External Bus Bars Horizontal Distribution Bay (WIDE),Rated at 5000 Amps,1 per bay	
CC109170214	Vertical External Bus Bars Horizontal Distribution Bay (WIDE),Rated at 10000 Amps,1 per bay	
CC109173175	Vertical External Bus Bars Horizontal Distribution Bay (Std),Rated at 5000 Amps,1 per bay	

This modular external return bus kit is an alternative to standard external or internal return buses. It allows for modular growth of the bars from bay to bay. The bar is designed to accept both small and large cable terminations to support many varying conditions. Please contact OmniOn for additional options for external return bus bars.

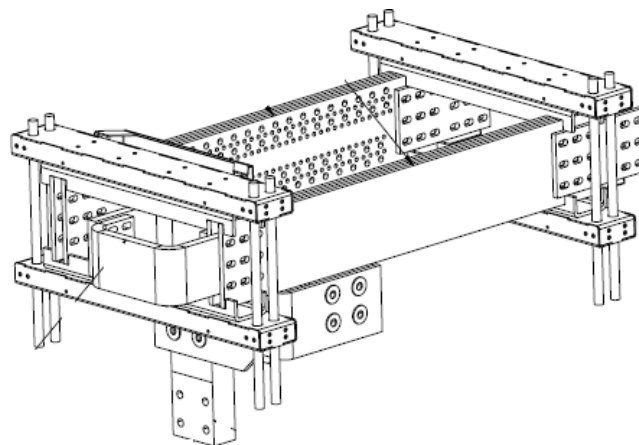

Horizontal Modular Distribution Bay Overhead Bus

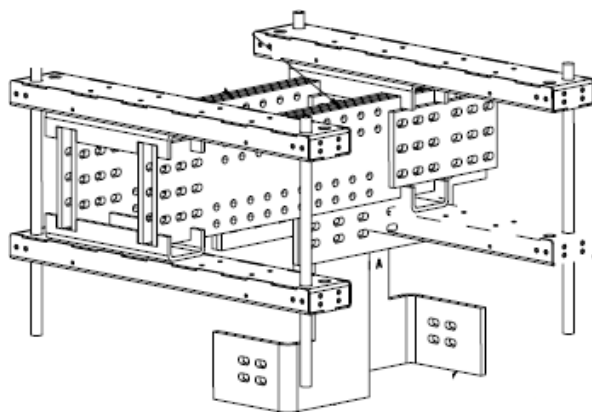

Field option A

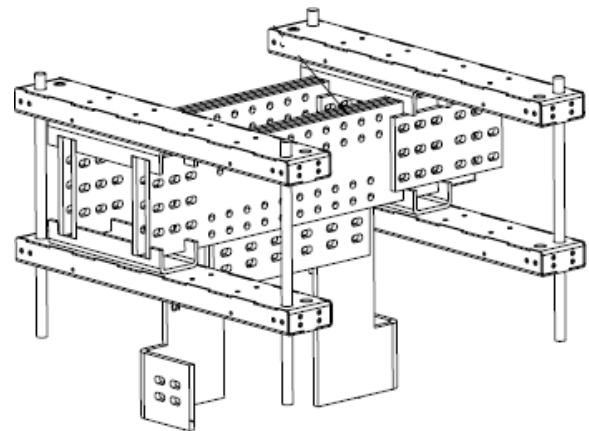

Field option B

Rectifier Bay Overhead Bus

Notes

A series of horizontal dotted lines for taking notes.

Management Visibility

Galaxy Manager* software is the centralized visibility and control component of a comprehensive power management system designed to meet engineering, operations and maintenance needs. The Galaxy Manager client-server architecture enables remote access to system controllers across the power network.

- Dashboard display with one-click access to management information database
- Trend analysis
- Scheduled or on demand reports
- Fault, configuration, asset, and performance management

Training

OmniOn offers on-site and classroom training options based on certification curriculum. Technical training can be tailored to individual customer needs. Training enables customers and partners to more effectively manage and support the power infrastructure. We have built our training program on practical learning objectives that are relevant to specific technologies or infrastructure design objectives.

Service & Support

OmniOn field service and support personnel are trusted advisors to our customers always available to answer questions and help with any project, large or small. Our certified professional services team consists of experts in every aspect of power conversion with the resources and experience to handle large turnkey projects along with custom approaches to complex challenges. Proven systems engineering and installation best practices are designed to safely deliver results that exceed our customers' expectations.

Warranty

OmniOn is committed to providing quality products and solutions. We have developed a comprehensive warranty that protects you and provides a simple way to get your products repaired or replaced as soon as possible.

For full warranty terms and conditions please go to

[omnionpower.com](https://www.omnionpower.com)

OmniOn Power Inc.

601 Shiloh Rd.
Plano, TX USA

omnionpower.com

We reserve the right to make technical changes or modify the contents of this document without prior notice. OmniOn Power does not accept any responsibility for errors or lack of information in this document and makes no warranty with respect to and assumes no liability as a result of any use of information in this document.

We reserve all rights in this document and in the subject matter and illustrations contained therein. Any reproduction, disclosure to third parties or utilization of its contents – in whole or in parts – is forbidden without prior written consent of OmniOn Power. This document does not convey license to any patent or any intellectual property right. Copyright© 2023 OmniOn Power Inc. All rights reserved.