

PRODUCT MANUAL

Galaxy Power System 4848/100 with Dual Rectifier Shelf (GPS 4848/100) H569-434

Note: Instructions in this manual reference installation and setup of the Galaxy Millennium Controller. For Galaxy Millennium II installation and setup, refer to the Millennium II Product Manual 167-792-181.

Notice:

The information, specifications, and procedures in this manual are subject to change without notice. OmniOn Power assumes no responsibility for any errors that may appear in this document.

This page intentionally left blank

PRODUCT MANUAL

Galaxy Power System 4848/100 with Dual Rectifier Shelf (GPS 4848/100) H569-434

TABLE OF CONTENTS

1 Introduction

GPS 4848/100	13
Overview.....	13
Illustration	14
Safety.....	15
Electromagnetic Compliance	15
CE Marking	15
Telcordia	15
Customer Service Contacts	15
Customer Service, Technical Support, Product	
Repair and Return, and Warranty Service.....	15
Customer Training	16
Downloads and Software	16

2 System Description

Overview	17
Block Diagram.....	17
System Components.....	18
Architecture	18
Introduction	18
Distributed.....	18
Centralized.....	20
Standard.....	22
Non-Traditional	22

3 Galaxy Millennium Controller

Overview	23
Mounting Location	23

Circuit Boards	23
Reference Material.....	23
Controller Product Manual.....	23
RPM System Product Manual	23
User Interface and Display	23
Front Panel	23
Default Display	24
LEDs	24
Pushbutton Controls.....	24
Test Jacks	24
4 Rectifiers	
595 Series.....	25
Overview.....	25
Front Panel Display.....	25
Power Switch	25
Status Indicators.....	25
Current Display	25
Lamp Test	26
Illustration	26
Features	26
Output Voltage Adjustment.....	26
Output Current “Walk-in”	26
Electronic Current Limit.....	26
Selective High Voltage Shutdown (SHVSD)	26
Backup High Voltage Shutdown (BHVSD)	26
Restart.....	27
Output Circuit Breaker	27
Fan Alarm and Control	27
Thermal Alarm.....	27
Controller Communications Alarm	27
Autonomous Operation of the Rectifier	27
Connectorized	27

“Forced” Load Sharing	27
5 AC Input Panels	
Overview	29
AC Service	29
Illustrations	29
6 Battery Connection Panels	
Overview	35
Introduction	35
Distributed Architecture	35
Centralized Architecture	35
Illustrations	35
7 DC Distribution Panels	
Overview	41
Function	41
Illustrations	41
8 Circuit Boards	
Overview	49
Function	49
Terminal Boards	49
Alarm Boards	49
Alarm/Terminal Boards	49
BLJ Terminal Board	49
Bay Interface Card	49
Contactor Control Board	49
9 Specifications	
GPS 4848/100	51
Rectifiers	52
AC Input Panels	54
Battery Connection Panels	55
DC Distribution Panels	56
10 Safety	

11 Maintenance and Replacement

Requirements	57
System	57
Batteries	57
Controller	57
Rectifier	57
Vacant Rectifier Positions.....	57
Rectifier Fan Assembly.....	57
Replacement Procedures	58
Installing or Replacing a Rectifier.....	58
Removing a Rectifier.....	60
Replacing the Rectifier Fan Assemblies.....	61
Testing	62
Testing Additional Alarms After Replacing Rectifiers	62
Testing Rectifiers and Load Share in Bay Expansions.....	62
Replacement Parts	63
System	63
Millennium Controller Circuit Boards.....	63
Additional Ordering Information	64
Documentation	64
Software	64
12 Troubleshooting Preparations	
Preliminary	65
Introduction	65
Safety.....	65
Tools.....	65
Troubleshooting Procedure	65
Purpose	65
Cabinet Alarm	65
System Status.....	66
Alarms Menu.....	66
Troubleshooting Tables.....	67

Identifying Problems	67
Reference Figures	67
Figure Numbers and Titles	67
Millennium Controller	67
Rectifier	69
Low Voltage Battery Disconnect	70
AC Input	71
AC Input	72
DC Distribution	73
Low Voltage Load Disconnect	74
13 Troubleshooting Millennium Systems	
Introduction	75
In This Section	75
Preparation	75
Technical Assistance	75
Troubleshooting Tables	75
Organization	75
Table Reference	75
Rectifier Display Messages and LEDs	75
Millennium Controller Display	76
AC Alarm LED	76
BATT Alarm LED	77
CTRL Alarm LED	78
DIST Alarm LED	82
RECT Alarm LED	82
BD and RM Alarm LEDs, or No LED	87
14 Product Warranty	
Revision History	

This page intentionally left blank

LIST OF FIGURES

- Figure 1-1: GPS 4848/100 With Millennium Controller 14
- Figure 2-1: Block Diagram of the GPS 4848/100 (Distributed Architecture) 17
- Figure 2-2: Distributed Architecture 19
- Figure 2-3: Distributed Architecture Initial and Growth Cabinets 19
- Figure 2-4: Centralized Architecture 20
- Figure 2-5: Centralized Architecture Initial and Growth Cabinets 21
- Figure 2-6: Non-Traditional Cabling Arrangements 22
- Figure 3-1: Galaxy Millennium Controller Front Panel 23
- Figure 4-1: Rectifier Front Panel 26
- Figure 5-1: H569-434 G20/320/420 (ED83142-30 G3) 208/240V AC Input Circuit Breaker Panel - 4 Rectifier 29
- Figure 5-2: H569-434 G21/23/321/323/421 (ED83142-30 G4) 208/240/480V AC Input Circuit Breaker Panel - 6 Rectifier 29
- Figure 5-3: H569-434 G334/335 (ED83142-30 G24/25) 208/240/480V AC Input Circuit Breaker Panel - 12 Rectifier 30
- Figure 5-4: H569-434 G22/322 (ED83142-30 G2) 480V AC Input Circuit Breaker Panel - 4 Rectifier 30
- Figure 5-5: H569-434 G24/25/26/27/324/325/326/ 327/330/331 (ED83142-30 G5)208/240/480V AC Input Terminal Strip Panel - 6 Rectifier 31
- Figure 5-6: H569-434 G128/129/130/131 (ED83142-30G18) 208/240/480V AC Input Terminal Strip Panel - 8 Rectifier 31
- Figure 5-7: H569-434 G328/329/332/333 (ED83142-30G26) 208/240/480V AC Input Terminal Strip Panel -14 Rectifier 32
- Figure 5-8: H569-434 G70/370/470 (ED83142-30 G10)480V 65kAIC AC Input Circuit Breaker Panel 4 Rectifier 32
- Figure 5-9: H569-434 G71/371/471 (ED83142-30 G11) 480V 65kAIC AC Input Circuit Breaker Panel 6 Rectifier 33
- Figure 6-1: H569-434 G30 (ED83143-31 G32) Battery Connection Panel 35
- Figure 6-2: H569-434 G31 (ED83143-31 G31) Battery Connection Panel 36
- Figure 6-3: H569-434 G32/32A (ED83143-31 G30/30A) Battery Connection Panel 36
- Figure 6-4: H569-434 G34 (ED83143-31 G41) Battery Connection Panel 36
- Figure 6-5: H569-434 G35 (ED83143-31 G42) Battery Connection Panel 37
- Figure 6-6: H569-434 G37/38 (ED83143-31 G60/61) Battery (OLE) Connection Panel 37

Figure 6-7: H569-434 G80/81/82 (ED83143-31 G31/43) Battery Connection Panel 38

Figure 6-8: H569-434 G86/87 (ED83143-31 G63/64) Battery Connection Panel 39

Figure 6-9: H569-434 G39 (ED83143-31 G36) Battery Connection Panel..... 39

Figure 7-1: H569-434 G40/45/50/55 (ED83143-31 G11) 400A DC Distribution Panel..... 41

Figure 7-2: H569-434 G41/46/51/56 (ED83143-31 G12) 400A DC Distribution Panel..... 41

Figure 7-3: H569-434 G42/47 (ED83143-31 G2) 600A DC Distribution Panel 42

Figure 7-4: H569-434 G43 (ED83143-31 G1) 1200A DC Distribution Panel 42

Figure 7-5: H569-434 G48 (ED83143-31 G5) 1000A DC Distribution Panel 43

Figure 7-6: H569-434 G52 (ED83143-31 G53) 600A DC Distribution Panel 43

Figure 7-7: H569-434 G53/57 (ED83143-31 G55) 1000A DC Distribution Panel 44

Figure 7-8: H569-434 G60/61/65/66 (ED83143-31 G71) 600A DC Distribution Panel..... 44

Figure 7-9: H569-434 G67 (ED83143-31 G22) 600A DC Distribution Panel..... 45

Figure 7-10: H569-434 G68 (ED83143-31 G21) 1200A DC Distribution Panel..... 45

Figure 7-11: H569-434 G96 (ED83143-31 G15) 510A DC Distribution Panel 46

Figure 7-12: H569-434 G97 (ED83143-31 G16) 14-Position, and H569-434 G98 (ED83143-31 G17) 22-Position DC Distribution Panel 46

Figure 7-13: H569-434 G54 (ED83143-31 G54) 5- Position DC Distribution Panel 47

Figure 7-14: H569-434 G58 (ED83143-31 G58) 6- Position GMT DC Distribution Panel 47

Figure 7-15: H569-434 G59 (ED83143-31 G56) 2- Position Fuse Distribution Panel 48

Figure 11-1: Installing a Rectifier in a Rectifier Shelf..... 59

Figure 11-2: Rectifier Faceplate Assembly..... 61

Figure 11-3: Rectifier Fan Assembly 61

Figure 12-1: Location of Cabinet Alarm Light and Controller..... 66

Figure 12-2: Millennium Controller Display 68

Figure 12-3: Millennium Controller Fuses and Circuit Boards 68

Figure 12-4: Rectifier Display..... 69

Figure 12-5: Low Voltage Battery Disconnect Contactor Control Switches..... 70

Figure 12-6: AC Input Panel and Rectifier Positions, 6 Rectifiers..... 70

Figure 12-7: AC Input Panel and Rectifier Positions, 12 Rectifiers..... 72

Figure 12-8: DC Distribution Panel..... 73

Figure 12-9: Low Voltage Load Disconnect Contactor Control Switches 74

LIST OF TABLES

Table 9-A: Galaxy Power System 4848/100 Specifications	51
Table 9-B: 595LT Series Rectifier Specifications	52
Table 9-C: Rectifier Display Messages and LEDs	54
Table 9-D: AC Panels	54
Table 9-E: Battery Connection Panels	55
Table 9-F: DC Distribution Panels	56
Table 11-A: GPS 4848/100 Replacement Parts	63
Table 11-B: Galaxy Millennium Controller Circuit Boards	63
Table 11-C: Product Documentation	64
Table 13-A: AC Alarms	76
Table 13-B: Battery Alarms	77
Table 13-C: Controller Alarms	78
Table 13-D: Distribution Alarms	82
Table 13-E: Rectifier Related Alarms	82
Table 13-F: Miscellaneous Alarms	87

This page intentionally left blank

1 Introduction

GPS 4848/100

Overview

The Galaxy Power System (GPS) 4848/100 provides -48 volt telecommunications powering solutions in worldwide markets. The GPS 4848/100 combines 220 and 200-ampere, fan-cooled, switch mode rectifiers, microprocessor control technologies, battery and load disconnect/reconnect options, and a comprehensive line of fuse and circuit breaker dc distribution options in a modular front-access design. This modularity ensures easy access, simplified installation and maintenance, and allows the system to expand in capacity and features as power needs grow.

With 14,080-ampere maximum capacity, distribution flexibility, and universal ac input capability, the GPS 4848/100 supports switching, transmission, and wireless applications in central office locations and environmentally controlled remote sites (huts or vaults). For centralized architecture, bus bars are available to 14,080A.

Notes

This document includes information for 595LT series rectifiers. For information about 595A and 595B series rectifiers see the GPS 4848/100 product Manual.

595A and 595B series rectifiers (full width, one per shelf) are fully supported by GPS 4848/100 with Dual Rectifier Shelves.

GPS 4848/100 (continued)

Illustration

Figure 1-1 is an isometric view of the GPS 4848/100 with a Millennium Controller.

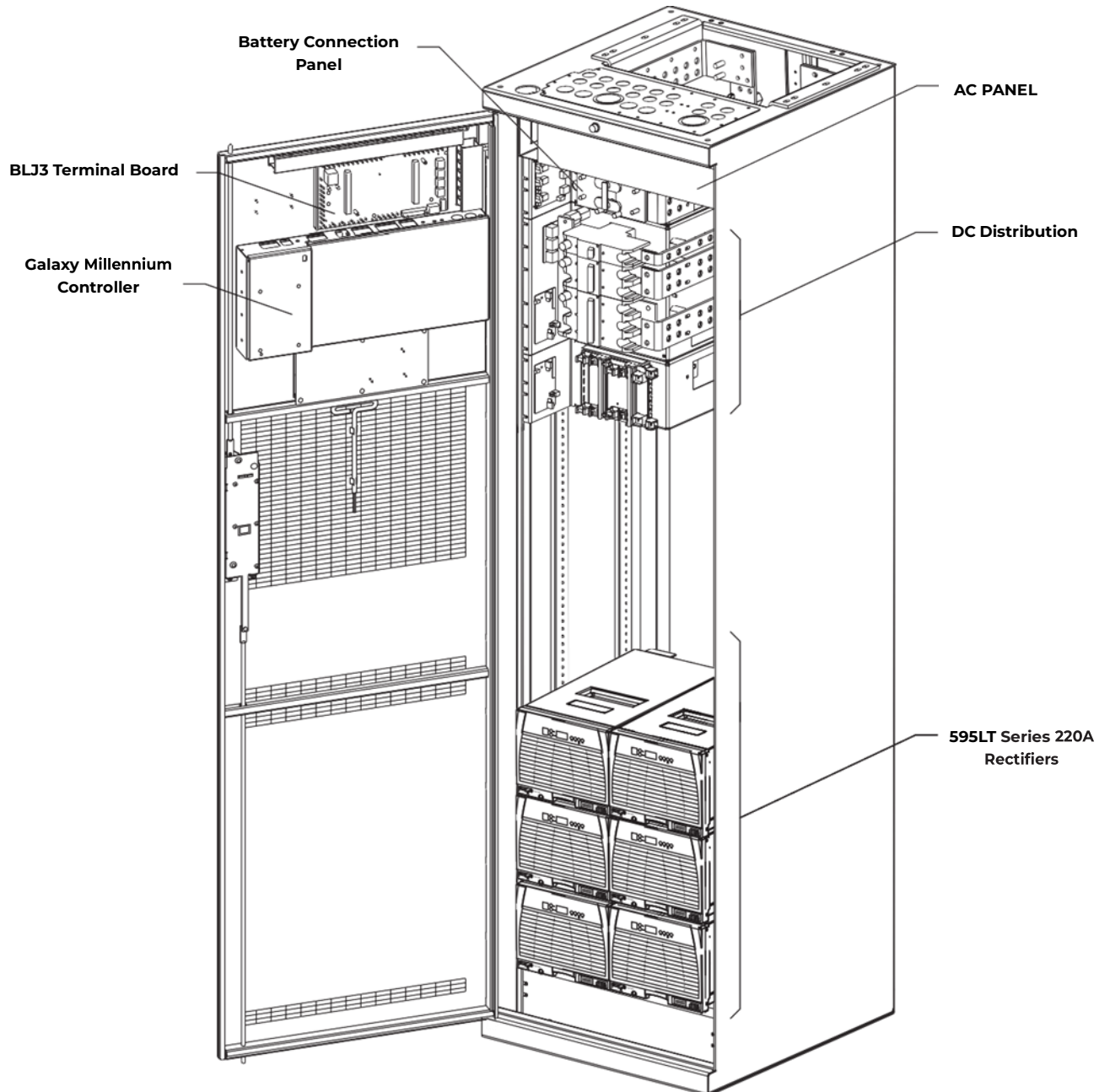

Figure 1-1: GPS 4848/100 With Millennium Controller

GPS 4848/100 (continued)

Safety

- UL¹ Listed (US and Canada): UL Subject 1801 with applicable sections of UL1950/CSA² 950)
- VDE Licensed to VDE 0805/IEC950/EN60950

Electromagnetic Compliance

- Emission:
 - FCC Part 15 Class B
 - EN55022 (CISPR 22) Radiated/Conducted Emission, Class B
- Immunity
 - IEC/EN 61000-4-2 ESD level 3 and 4
 - IEC/EN 61000-4-3 Radiated Immunity, 10V/m
 - IEC/EN 61000-4-4 Electrical Fast transients/Burst, level 4
 - IEC/EN 61000-4-5 Lightning Surge, level 4

CE Marking

- CE marked per European Union Council Directives:
 - Low-Voltage Directive (73/23/EEC) and
 - EMC Directive (89/336/EEC) as amended by CE Marking Directive (93/68/EEC)

Telcordia

- GR-63 and GR-1089 NEBS (including Level 3 testing)
- Report by an independent test laboratory - NRTL

Customer Service Contacts

Customer Service, Technical Support, Product Repair and Return, and Warranty Service

For customers in the United States, Canada, Puerto Rico, and the US Virgin Islands, call 1-877-546-3243 or 1-972-244-9288. This number is staffed from 7:00 am to 5:00 pm Central Time (zone 6), Monday through Friday, on normal business days. At other times this number is still available, but for emergencies only. Services provided through this contact include initiating the spare parts procurement process, ordering documents, product warranty administration, and providing other product and service information.

For other customers worldwide the 800 number may be accessed after first dialing the OmniOn Direct country code for the country where the call is originating, or you may contact your local field support center or your sales representative to discuss your specific needs.

1. UL is a registered trademark of underwriters Laboratories Inc.
2. CSA is registered trademark of Canadian Standards Association.

Customer Service Contacts (continued)

Customer Training

OmniOn Power offers customer training on many Power Systems products. For information call 1-877-546-3243 or 1-972-244-9288. This number is answered from 8:00 a.m. until 4:30 p.m., Central Time Zone (Zone 6), Monday through Friday.

Downloads and Software

To download the latest product information, product software and software upgrades, visit our web site at [omnionpower.com](https://www.omnionpower.com)

2 System Description

Overview

Block Diagram

Figure 2-1 shows a basic block diagram of the Galaxy Power System 4848/100. It illustrates the arrangement and interconnections of the system components from the ac input to the dc output.

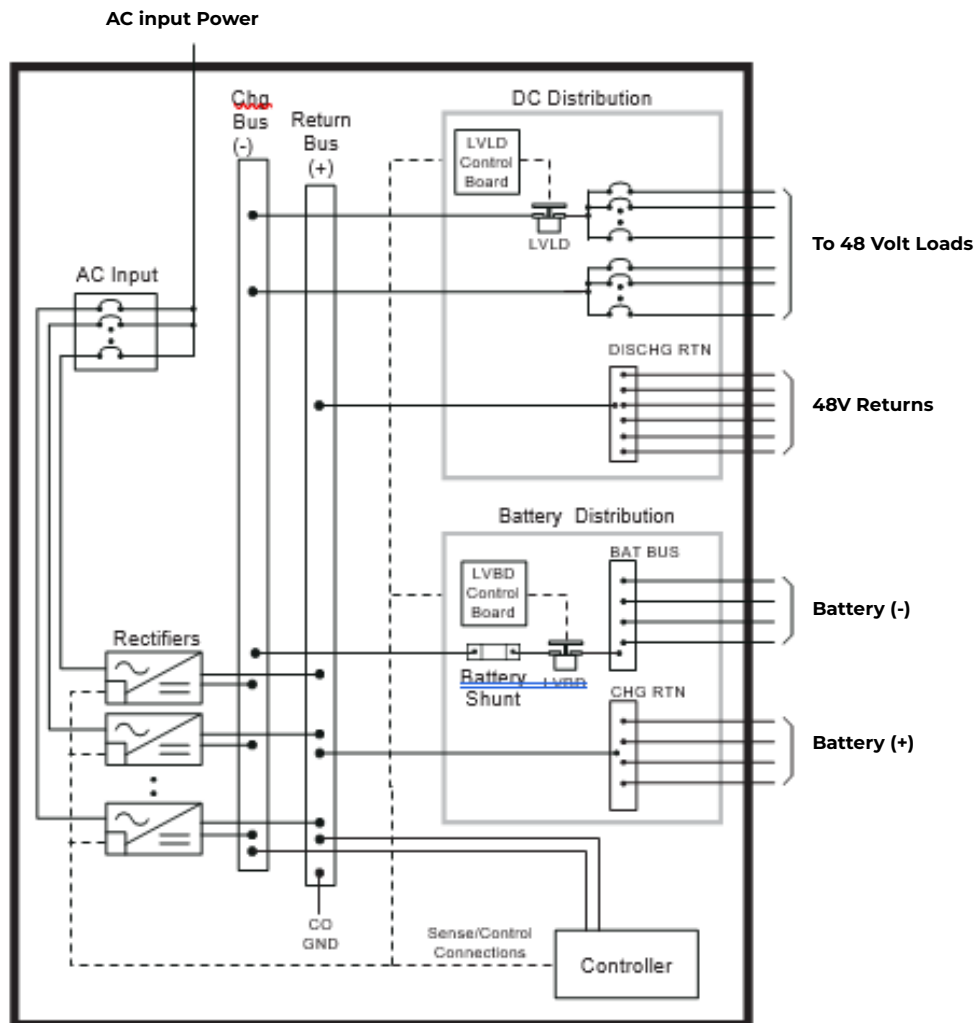

Figure 2-1: Block Diagram of the GPS 4848/100 (Distributed Architecture)

Overview (continued)

System Components

The power system accepts alternating current from the commercial utility or a standby ac power source and rectifies it to produce dc power for the using equipment. The system's control and alarm functions interact with the rectifiers and the office. In addition, the system provides overcurrent protection and charge, discharge, and distribution facilities. Battery reserve automatically provides a source of dc power if the commercial or standby ac fails. Battery reserve can be engineered to supply dc power for a specific period of time. In normal practice, battery capacity is sized to provide 3 to 8 hours of reserve time.

AC Input connects the commercial and/or standby ac power sources to the rectifiers within the system and provides overcurrent protection. In some applications the ac service is wired directly to the rectifiers and overcurrent protection is provided at the service panel.

Rectifiers convert an ac source voltage into the dc voltage level required to charge and float the batteries and to power the using equipment.

Controller provides the local and remote control, monitoring, and diagnostic functions required to administer the power system.

Batteries provide energy storage for an uninterrupted power feed to the using equipment during loss of ac input or rectifier failure.

DC Distribution Panel provides overcurrent protection, connection points for the using equipment, and bus bars used to interconnect the rectifiers, batteries, and dc distribution.

Battery Connection Panel provides connection points for the battery strings through battery disconnect fuse, contactors, current monitoring shunts, and equalize converters.

Architecture

Introduction

For the GPS 4848/100 system, the basic system components, i.e., ac input panels, battery connection panels, dc distribution panels, rectifiers, and controller, can be configured to form two distinct system architectures: distributed or centralized.

Distributed

In this system each cabinet contains ac distribution, dc distribution panels, battery connection panels, rectifiers, termination points for load circuits, and a battery shunt. The initial cabinet also contains the system controller and, as such, it can function as a stand-alone system. The rectifier output buses are interconnected to permit cabinets to share current and ensure common voltage references for all system rectifiers. Because each cabinet is basically a self-contained system, the overall system capacity can be increased by simply adding cabinet/battery entities. However, growing the system requires a distinct, dedicated floor plan.

Architecture (continued)

During normal operation, the readings from the battery shunts are summed and subtracted from the rectifier current to obtain the system load current. While the batteries are providing the system load power, the individual battery shunts may be monitored to determine the status of the individual battery sections.

Cabinets can be equipped with load and/or battery disconnect/reconnect contactors. Battery contactors prevent battery damage during deep discharges by disconnecting batteries. Load contactors can extend the time critical loads operate on battery discharge by disconnecting

non-critical loads during discharge.

Figure 2-2 shows an example of GPS 4848/100 components configured in a distributed architecture; Figure 2-3 gives a front view of the distributed initial and growth cabinets.

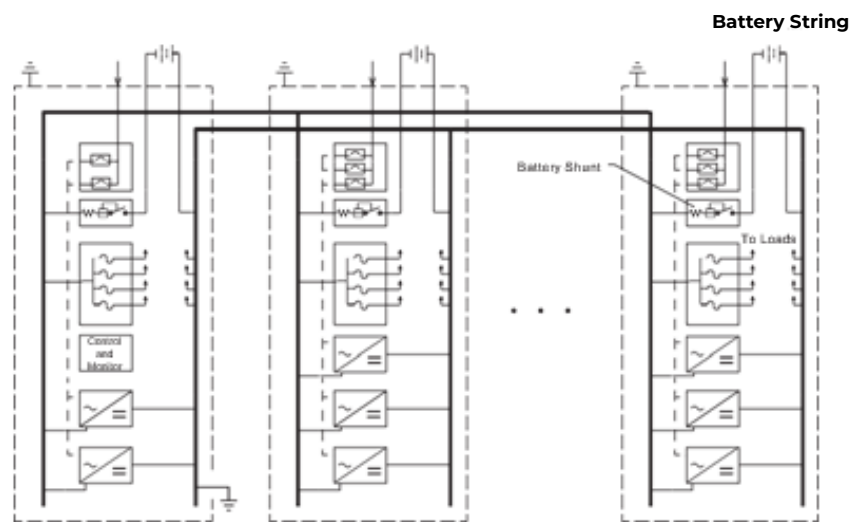

Figure 2-2: Distributed Architecture

Architecture (continued)

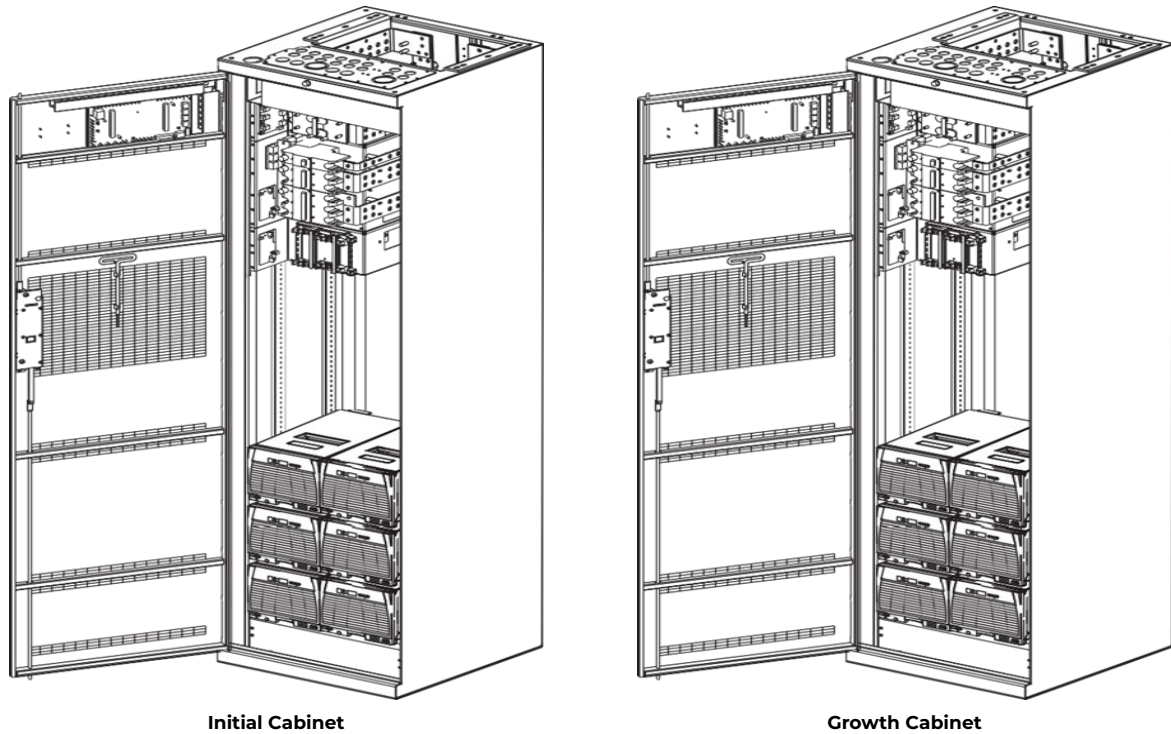

Figure 2-3: Distributed Architecture Initial and Growth Cabinets

Centralized

Figure 2-4 shows GPS 4848/100 components configured in a centralized architecture; Figure 2-5 provides a view of the centralized architecture initial and growth cabinets. Rectifiers, dc distribution panels, and batteries are cabled to external busbars where a single system shunt is provided to measure total system load current. The initial cabinet contains ac distribution, rectifiers, the controller, and termination points for the system interconnect cables. Growth cabinets contain ac distribution, rectifiers, and cable termination points. A separate cabinet provides load distribution and protection facilities and may include load disconnect/reconnect contactors.

This architecture requires extensive up-front planning to determine the ultimate system capacity and engineering to size the external busbars appropriately; however, the system plan is not constrained to dedicated layouts as required for distributed architecture systems.

Architecture (continued)

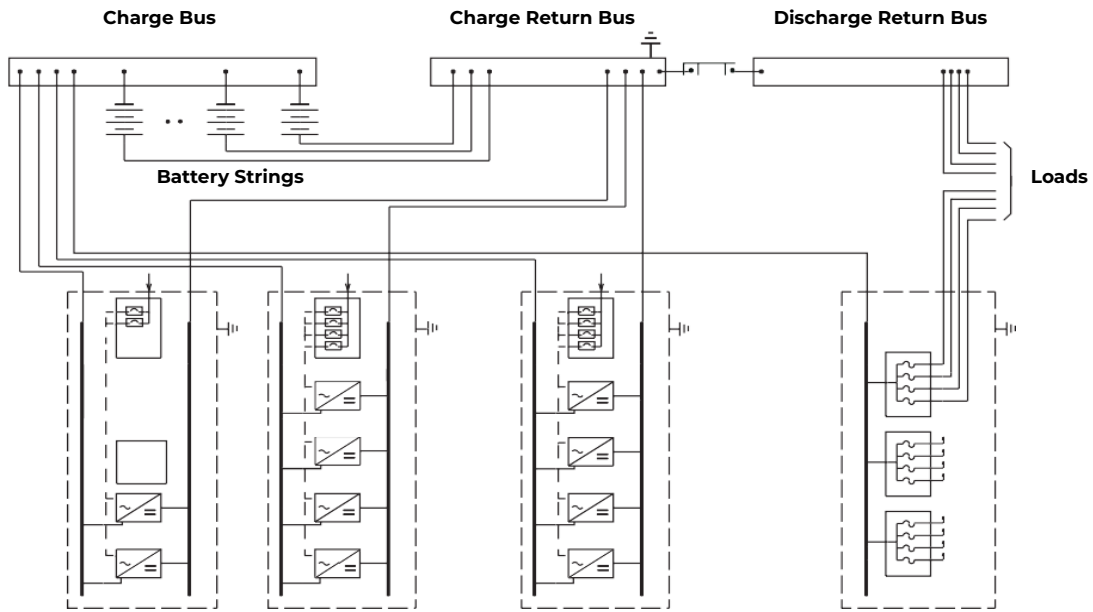

Figure 2-4: Centralized Architecture

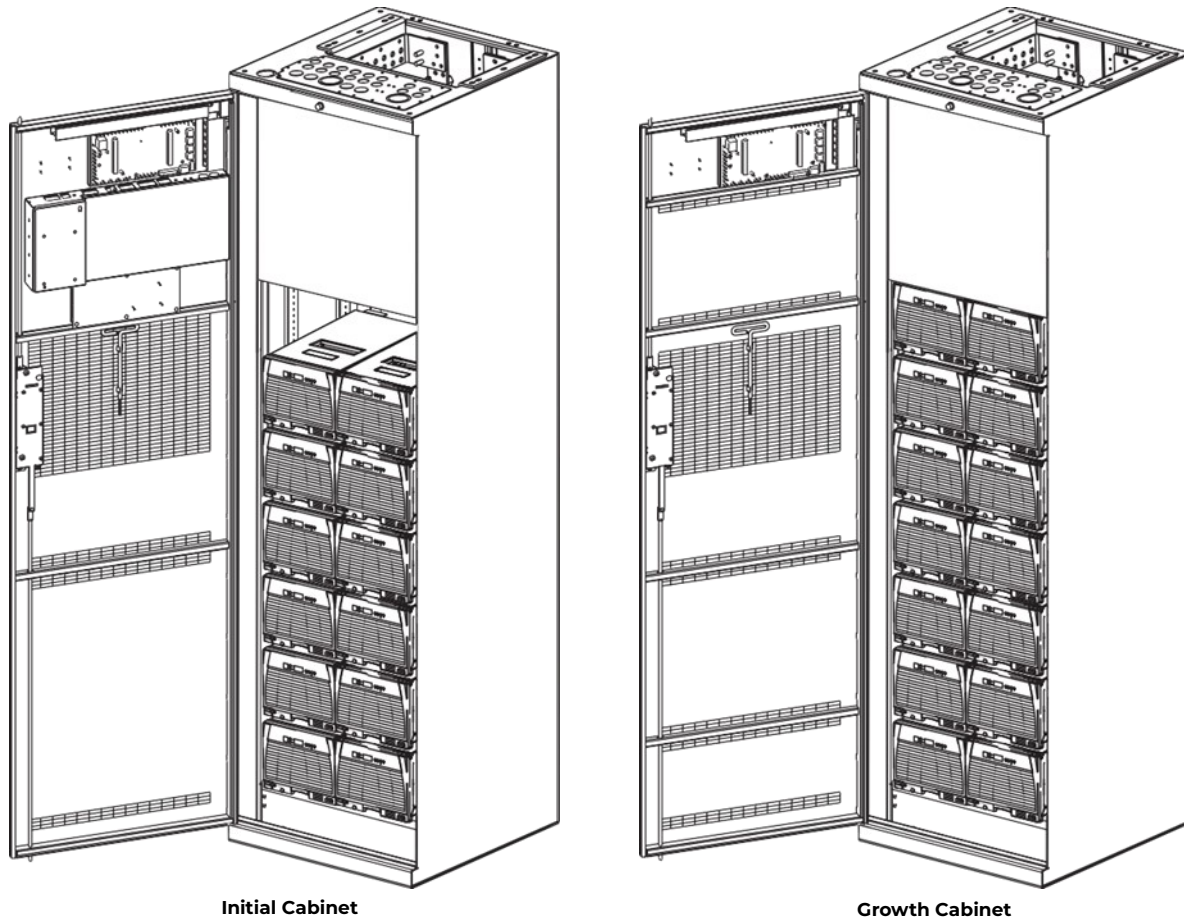

Figure 2-5: Centralized Architecture Initial and Growth Cabinets

Cabinet Cabling Options

Standard

Standard cabinets are designed so that ac, battery, and dc load cables are run through the top of the cabinet.

Non-Traditional

Any of the battery panels and dc load panels (shown in Sections 6 and 7) may be used in cabinets that have non-traditional cabling orientations. However, only G20, G22, G24, G26, and G27 ac panels (shown in Section 5) are available for these cabinets (see Figure 2-6). Suffixes of the ac panels indicate the cabling arrangements listed below:

AC Panel Suffix	Cabling Arrangement	
	AC	Battery and DC Load
A	Through bottom of cabinet	Through bottom of cabinet
B	Through bottom of cabinet	Through top of cabinet
C	Through top of cabinet	Through bottom of cabinet

Note: Check H569-434 for availability

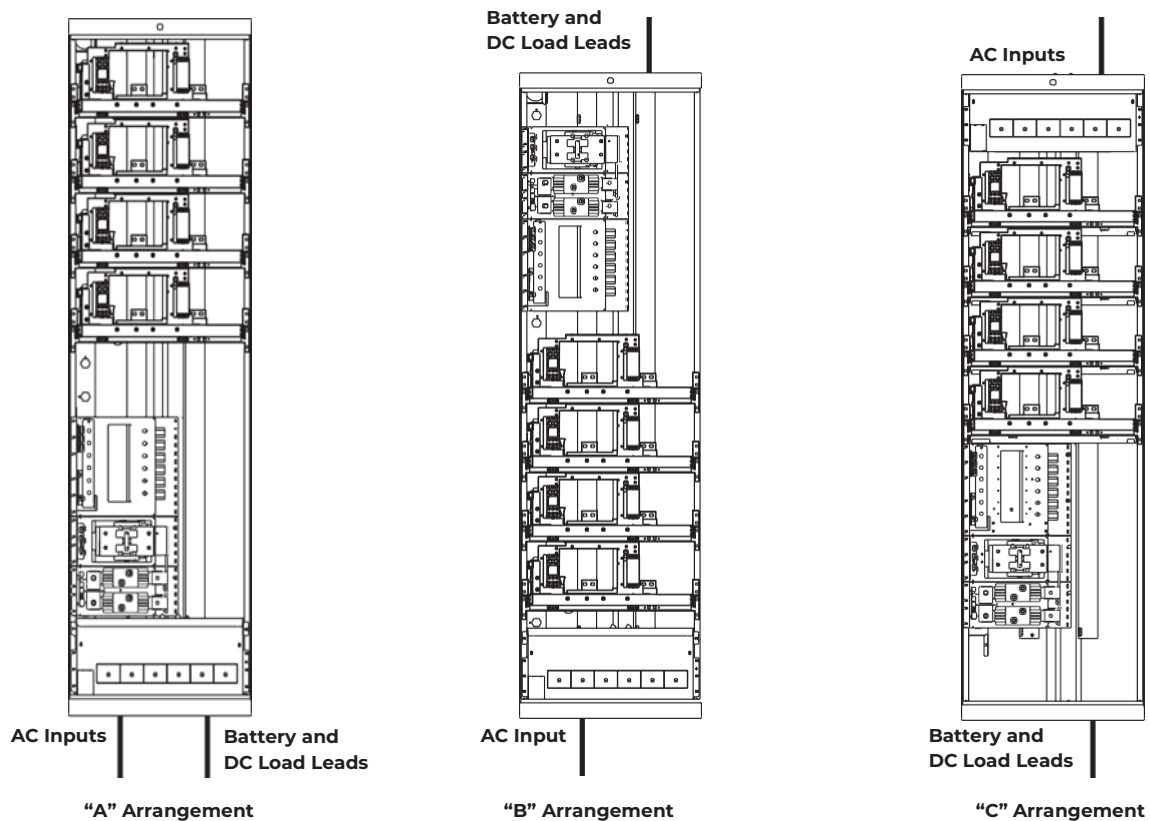

Figure 2-6: Non-Traditional Cabling Arrangements

3 Galaxy Millennium Controller

Overview

Mounting Location

The Galaxy Millennium Controller mounts inside the front door with the display viewed from the outside

Circuit Boards

The Galaxy Millennium Controller is equipped with a Basic control board for basic operations and an optional Intelligent control board that provides advanced local and remote monitoring and data acquisition features. These control boards monitor each other's status and issue appropriate alarms in the event a failure occurs. Circuit packs are accessed by opening the hinged cover from the left side.

Reference Material

Controller Product Manual

A Galaxy Millennium Controller, Select Code 167-792-180, is furnished with every GPS 4848/100. Refer to the manual for information regarding configuration and operation.

RPM System Product Manual

Refer to the Galaxy Remote Peripheral Monitoring System product manual (Select Code 167-790-063) for additional information regarding module operation

User Interface and Display

Front Panel

The control panel displays alarm and status indicators and provides test jacks to monitor the system output. Keys are provided for interacting with various menus that configure and monitor the system. The controller menus can be viewed in either English or Spanish.

The user's primary interface with the controller is a panel that includes a backlit LCD front panel display, two rows of LEDs, test jacks, and an array of simple pushbutton controls. See Figure 3-1.

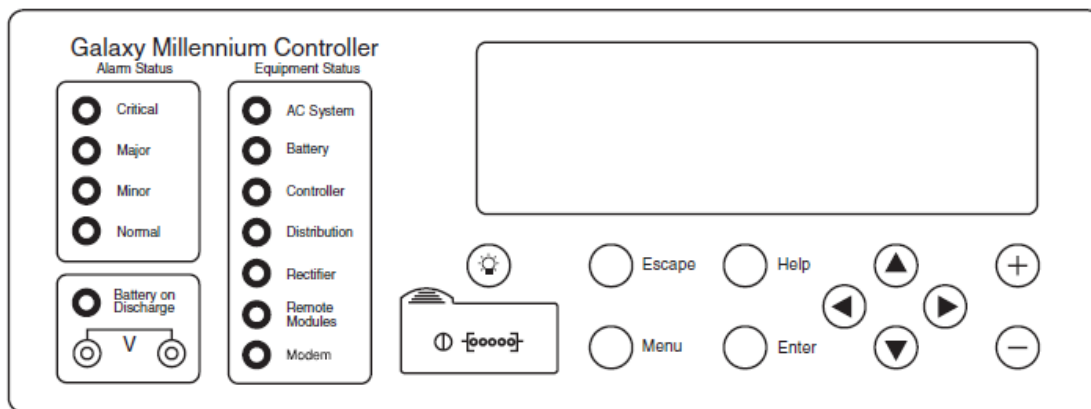

Figure 3-1: Galaxy Millennium Controller Front Panel

User Interface and Display (continued)

Default Display

The default display shows basic plant status. The controller returns to this display three minutes after the last time a key is pressed. The default screen display is similar to the following: The first line shows the number of alarms (0) and warnings (0) present in the system, the date and time. The next two lines show the plant voltage and the plant load. The last line shows the plant mode, which can be FLOAT, BOOST, STC (Slope Thermal Compensation), BTP (Battery Thermal Protection, a boost mode that offers protection against thermal runaway), or BATT TEST mode.

The information on the screen is updated automatically approximately every two seconds.

LEDs

Two columns of LEDs show the severity and source of active alarms. An alarm event may activate two LEDs: one Alarm Status LED and one Equipment Status LED. More than one of the Equipment Status LEDs may be active simultaneously. In that case, the Alarm Status LED that is active will be that of the most severe active alarm.

The first column has five LEDs. The first four indicate the severity of the reported alarms: Critical, Major, Minor, and Normal. The fifth LED, labeled Battery on Discharge, illuminates when the plant voltage is below the threshold set for this alarm condition in the plant configuration.

The second column includes seven LEDs, six of which indicate the source of the alarm: AC System, Battery, Controller, Distribution, Rectifier, or Remote Module. The final Modem LED will be active whenever the controller modem port is in use.

The pushbutton identified with an illuminated lamp icon can be used to test the controller's circuit pack and front panel LEDs. It will also test the indicators of all serially connected devices.

Pushbutton Controls

A group of pushbutton keys beneath the backlit LCD display provides the primary user interface with the controller. These keys are used singly or in combination to navigate through the controller's menus. The following is the general description of these keys.

- Up arrow key: Use to navigate the menu; press the key to move the cursor up one line.
- Down arrow key: Use to navigate the menu; press the key to move the cursor down one line.
- Left arrow key: Use to navigate the menu; press the key to move the cursor left one field.
- Right arrow key: Use to navigate the menu; press the key to move the cursor right one field.
- MENU key: Press this key any time to view the MAIN menu.
- HELP key: Press this key to display limited on-line help information.
- ENTER key: Use this key to select a menu item.
- ESCAPE key: Use this key to return to the immediately higher level menu.

Test Jacks

A pair of test jacks allows direct measurement of the system voltage being monitored, normally the battery voltage. This is the same point regulated as system voltage and displayed on the front panel

4 Rectifiers

595 Series

Overview

Four rectifiers are available for the GPS 4848/100 system with dual rectifier shelves: 595A Series, 595B Series, 595LTA Series, and 595LTB Series.

GPS4848/100 Rectifiers			
Series	DC Current	Rectifiers per Shelf	3-Phase AC Input Voltage
595A	200A	1	320-530Vac
595B	200A	1	170-260Vac
595LTA	220A	2	320-530Vac
595LTB	220A	2	170-260Vac

The rectifiers are shipped separately from the cabinets for quick and straightforward installation into rectifier shelves at the site.

Interconnections to ac input, dc output, and control signals occur automatically during insertion. The rectifiers are keyed to prevent installation of a rectifier with incompatible ac input. No operational settings or adjustments to potentiometers are necessary. The installer must set the rectifier's ID using the ON/STBY switch to allow the controller to identify the rectifier for status and alarm reporting.

595A and 595B series rectifiers (full width, one per shelf) are fully supported. See GPS 4848/100 User's Guide for views and other details of 595A and 595B series rectifiers.

Front Panel Display

Power Switch

This three-position switch has two functions:

- It controls the on/standby state of the rectifier.
- It is used to set the rectifier ID.

Status Indicators

In addition to the ON and STBY LEDs, four other LEDs on the rectifier's faceplate indicate the rectifier's condition.

- The ALM LED is red and lights when a thermal alarm occurs or a rectifier fail condition occurs. This LED blinks when communication with the plant controller is not active.
- The LIM LED is yellow lights when the unit is in current limit.
- The FAN ALM LED is red and lights when the fan inside the rectifier is not functioning properly.
- The EQL LED is yellow and lights when the rectifier is in equalize mode.

Current Display

This display indicates the current of the rectifier. Upon specific no-power conditions, the 3-digit display will show informative messages.

Front Panel Display (continued)

Lamp Test

To test the LEDs on the rectifier front panel, use the Lamp Test feature of the controller.

Illustration

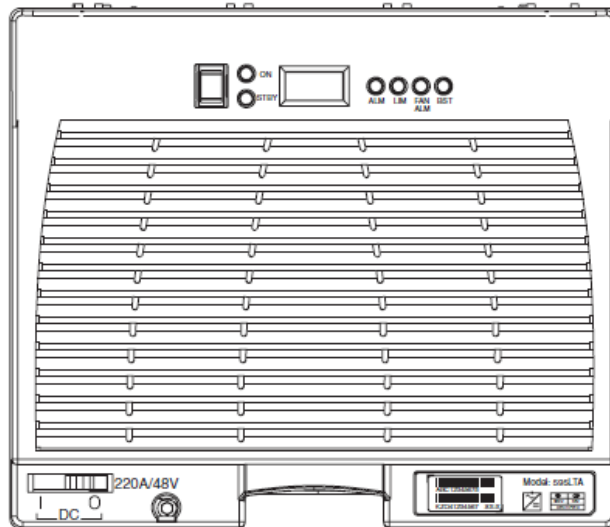

Figure 4-1: Rectifier Front Panel

Features

Output Voltage Adjustment

This feature allows the rectifier output voltage to be set and regulated by the controller.

Output Current “Walk-in”

This feature controls the time (up to eight seconds) required for the rectifier to reach normal operating conditions after it is turned on. This feature minimizes the starting surge on the customer's power source.

Electronic Current Limit

When the output current tends to increase above the current limit set point (30% to 100% of maximum output), the current limit circuit overrides voltage regulation and load share to safely limit the output current of the rectifier, thus preventing damage to itself, the battery, or the load.

Selective High Voltage Shutdown (SHVSD)

This feature allows the rectifier to respond and shut down at the output high voltage threshold set through the Galaxy controller.

Backup High Voltage Shutdown (BHVSD)

This is a hardwired feature independent of the rectifier's microcontroller. This feature is always active and will operate whether communicating with the controller or not and whether the rectifier's microcontroller is active or failed.

Features (continued)

Restart

Upon shutdown, the rectifier will attempt to restart. The rectifier will try to restart three times before issuing a rectifier fail alarm to the controller. The rectifier will also accept a restart command from the controller for a remote restart.

Output Circuit Breaker

The output circuit breaker located on the front panel protects the power system from rectifier malfunction and may be used to disconnect the rectifier from the system output bus.

Fan Alarm and Control

The rectifier contains two cooling fans whose speed is based on ambient temperature and output power level. The fan's speed is lowered during low-load and low-temperature conditions to minimize audible noise and maximize fan life.

Thermal Alarm

The rectifier senses the internal operating temperature and will issue a thermal alarm if the internal temperature exceeds a safe operating level. Ambient temperatures above the maximum rating may result in a rectifier shutdown and the issuing of a thermal alarm (TA).

Controller Communications Alarm

When communications between the rectifier and controller are interrupted, the rectifier continues to operate and the red ALM LED on the rectifier blinks.

Autonomous Operation of the Rectifier

If communication with the Galaxy controller is lost, the rectifier will continue to operate and deliver regulated power to the system load.

Connectorized

The rectifiers provide the controller with a full complement of status and alarm messages. The rectifier status and alarm signals, ac input, and dc output are all connectorized for easy installation and maintenance. All connections automatically occur as the rectifier is physically mated to its shelf.

“Forced” Load Sharing

The controller forces rectifiers to load share by sending messages to them. In the event communication to the controller is lost or the controller malfunctions, load share balance is maintained while ac or dc power is continuously applied to the rectifiers.

This page intentionally left blank

5 AC Input Panels

Overview

AC Service

The ac input panel provides the facility to terminate the 3-phase ac service to the GPS 4848/100. Depending upon the option ordered, the panel will connect 3-wire delta or 3-wire wye service to provide the phase-to-phase ac voltage required for the rectifiers.

In some systems, circuit breakers are provided in the AC Input Panel to protect the conductors providing ac service to the individual rectifiers. In other systems, the circuit breakers protecting these conductors are located in the building's ac service panel. In either case, conductors to each rectifier are protected by a dedicated circuit breaker.

Note: All wire sizes were based on the US National Electric Code

Illustrations

Circuit breaker panels are shown in Figures 5-1 through 5-4, 5-8, and 5-9. Terminal strip panels are shown in Figures 5-5 through 5-7.

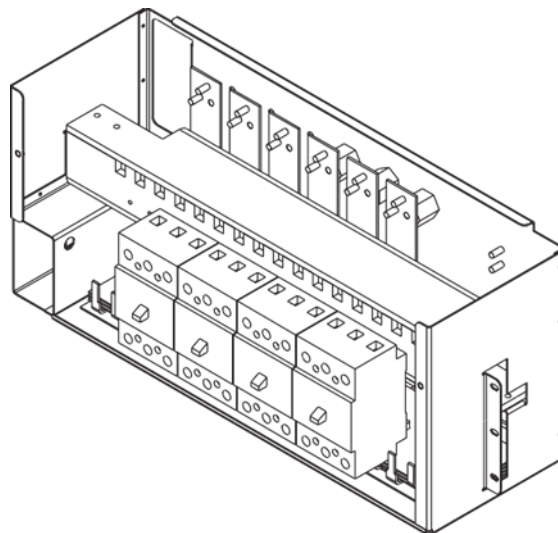

Figure 5-1: H569-434 G20/320/420 (ED83142-30 G3) 208/240V AC Input Circuit Breaker Panel - 4 Rectifier

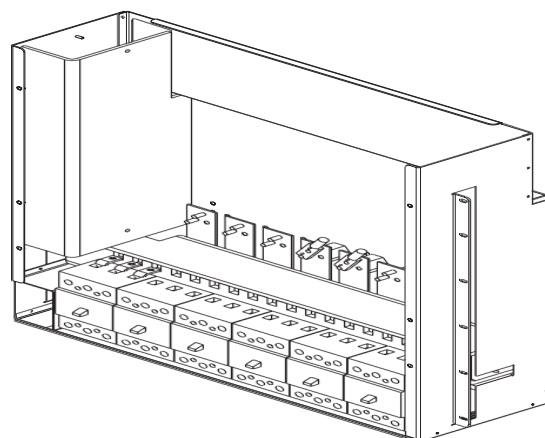

Figure 5-2: H569-434 G21/23/321/323/421 (ED83142-30 G4) 208/240/480V AC Input Circuit Breaker Panel - 6 Rectifier

5 AC Input Panels (continued)

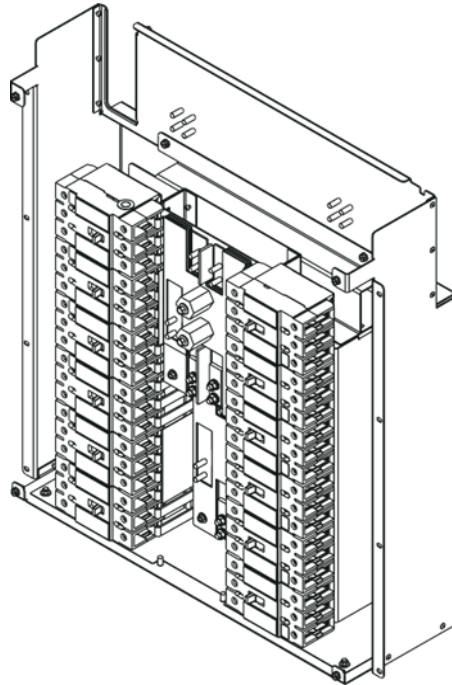

Figure 5-3: H569-434 G334/335 (ED83142-30 G24/25) 208/240/480V AC Input Circuit Breaker Panel - 12 Rectifier

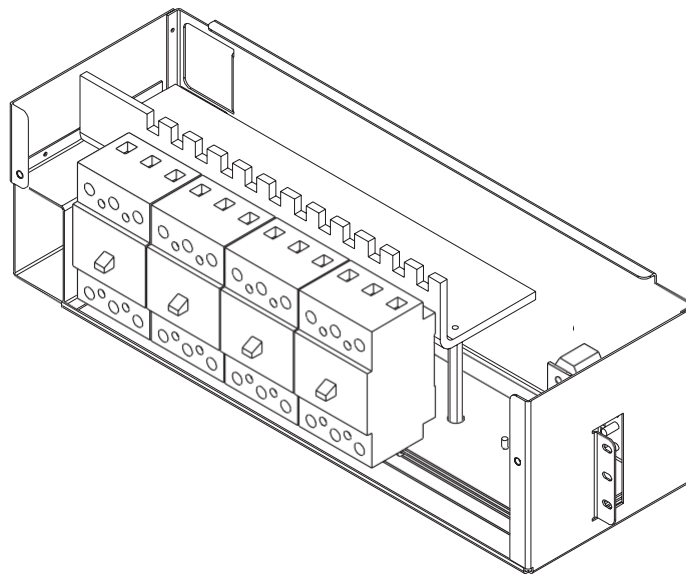

Figure 5-4: H569-434 G22/322 (ED83142-30 G2) 480V AC Input Circuit Breaker Panel - 4 Rectifier

5 AC Input Panels (continued)

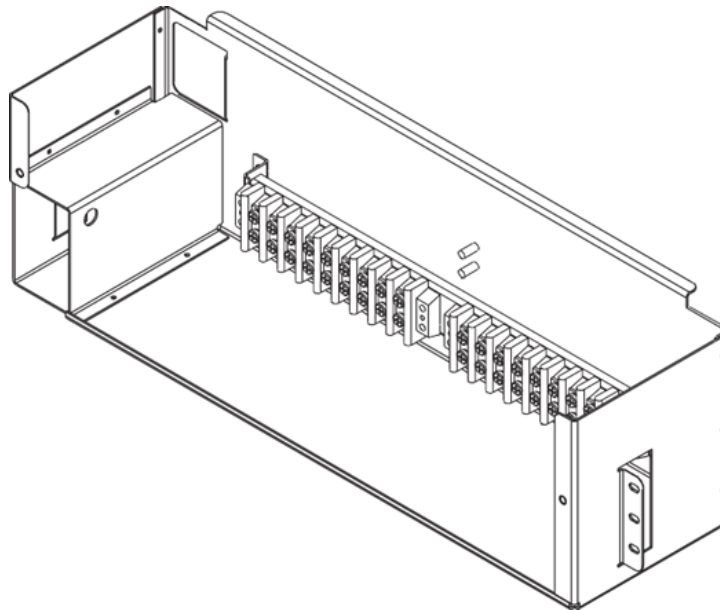

Figure 5-5: H569-434 G24/25/26/27/324/325/326/327/330/331 (ED83142-30 G5) 208/240/480V AC Input Terminal Strip Panel - 6 Rectifier

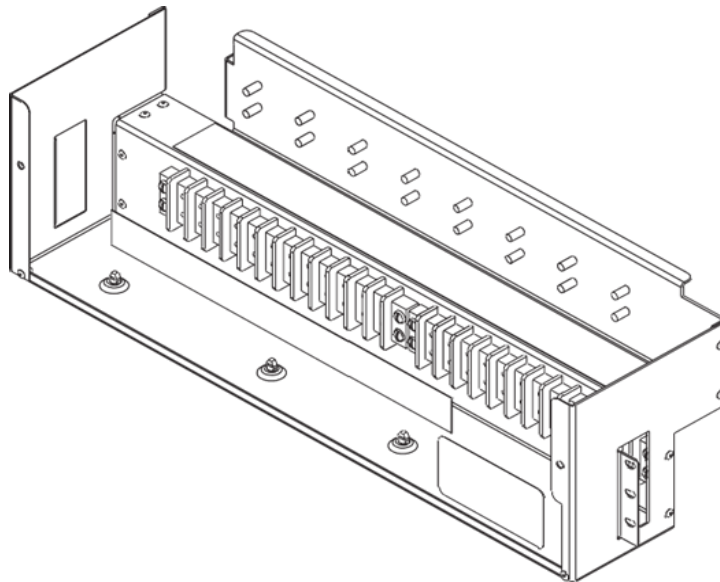

Figure 5-6: H569-434 G128/129/130/131 (ED83142-30 G18) 208/240/480V AC Input Terminal Strip Panel - 8 Rectifier

5 AC Input Panels (continued)

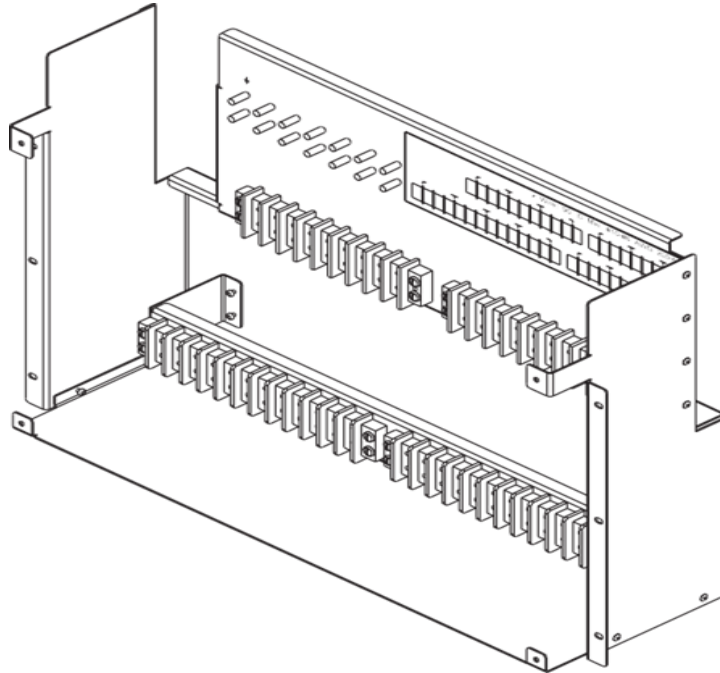

Figure 5-7: H569-434 G328/329/332/333 (ED83142-30 G26) 208/240/480V AC Input Terminal Strip Panel - 14 Rectifier

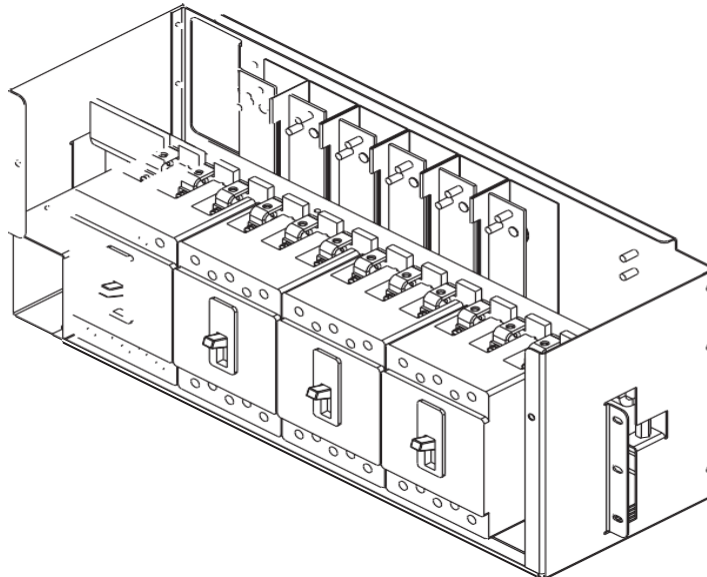

Figure 5-8: H569-434 G70/370/470 (ED83142-30 G10) 480V 65kAIC AC Input Circuit Breaker Panel - 4 Rectifier

5 AC Input Panels (continued)

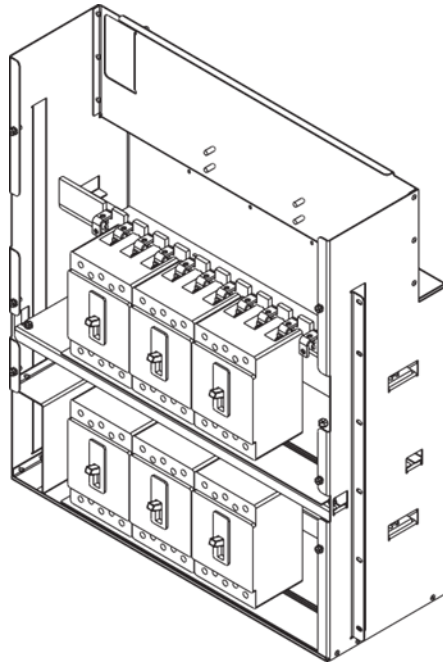

Figure 5-9: H569-434 G71/371/471 (ED83142-30 G11) 480V 65kAIC AC Input Circuit Breaker Panel - 6 Rectifier

This page intentionally left blank

6 Battery Connection Panels

Overview

Introduction

Batteries are connected to the GPS 4848/100 cabinets based on the system architecture.

Distributed Architecture

For distributed power architecture, the batteries are terminated on battery connection panels with shunts that monitor the battery charge / discharge current through circuits on the cabinet BIC (Bay Interface Card). These battery connection panels are located either in the very top of the cabinet (shunt-only panels) or directly below the ac input panel.

As options, these panels may also include fuses or low battery voltage disconnect/reconnect (LVBD/R) contactors. When equipped with contactor(s), contactor control card(s) provide local/manual control of the contactor(s) and communications with the controller for configured/ remote control.

Off Line Equalize (OLE) battery connection panels additionally provide means to manually equalize single battery sections. A plug-in dc to dc converter provides up to 65V to fully charge battery section cells, equalizing cell float voltages. This restores fully charged cell capacity to each cell in the section. A timer terminates the manually initiated equalize operation.

Centralized Architecture

For systems with centralized architecture, the batteries are connected between the system charge and charge return buses. In turn, these buses are connected to rectifier termination buses located behind the ac input panels.

Illustrations

The battery connection panels are illustrated in Figures 6-1 through 6-9.

Note: Battery connection panels are blue; dc distribution panels are white.

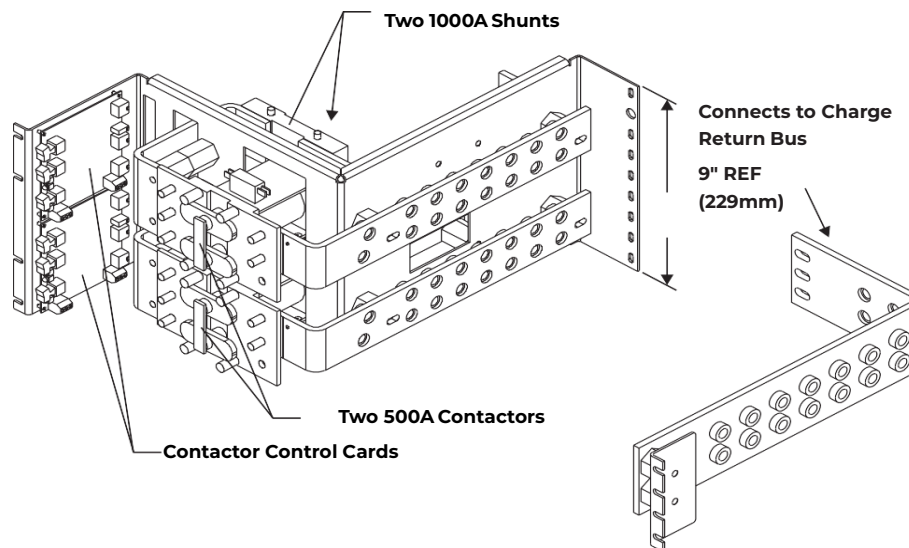

Figure 6-1: H569-434 G30 (ED83143-31 G32) Battery Connection Panel

6 Battery Connection Panels (continued)

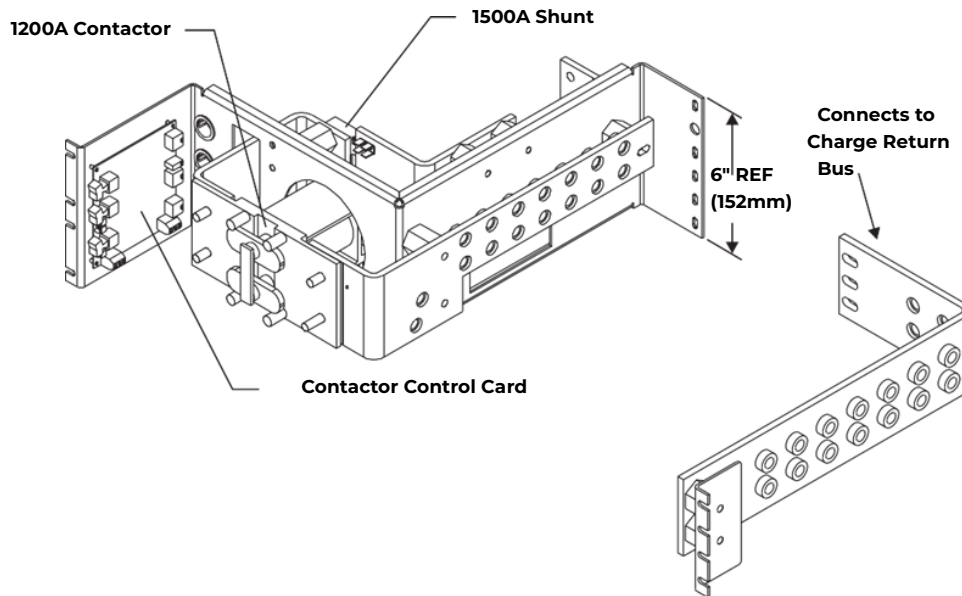

Figure 6-2: H569-434 G31 (ED83143-31 G31) Battery Connection Panel

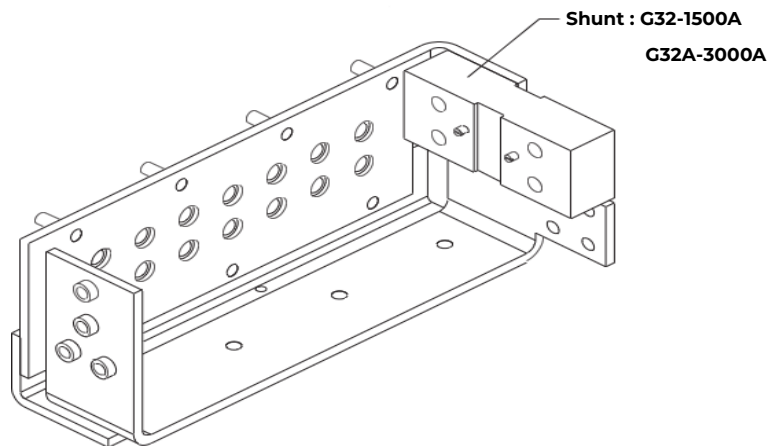

Figure 6-3: H569-434 G32/32A (ED83143-31 G30/30A) Battery Connection Panel

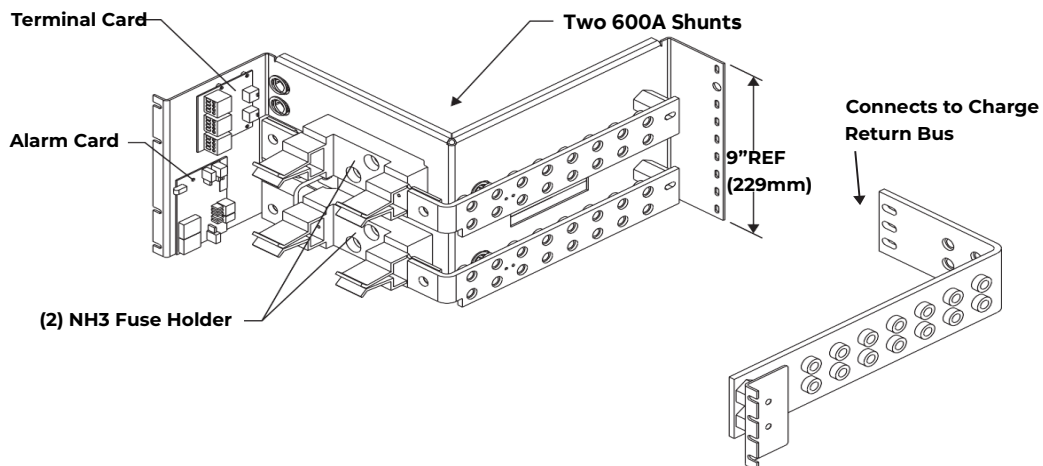

Figure 6-4: H569-434 G34 (ED83143-31 G41) Battery Connection Panel

6 Battery Connection Panels (continued)

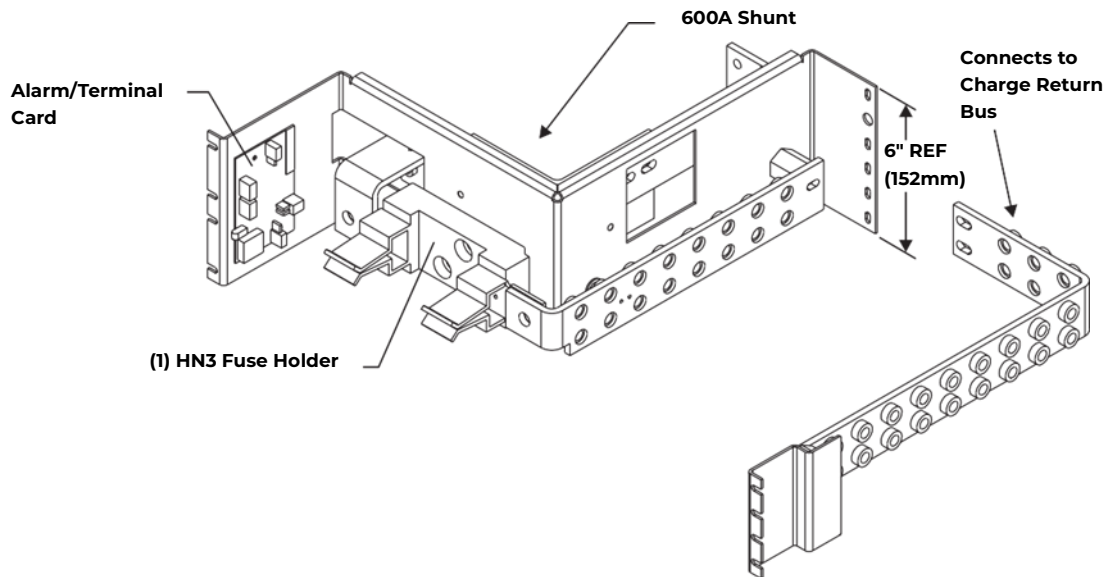

Figure 6-5: H569-434 G35 (ED83143-31 G42) Battery Connection Panel

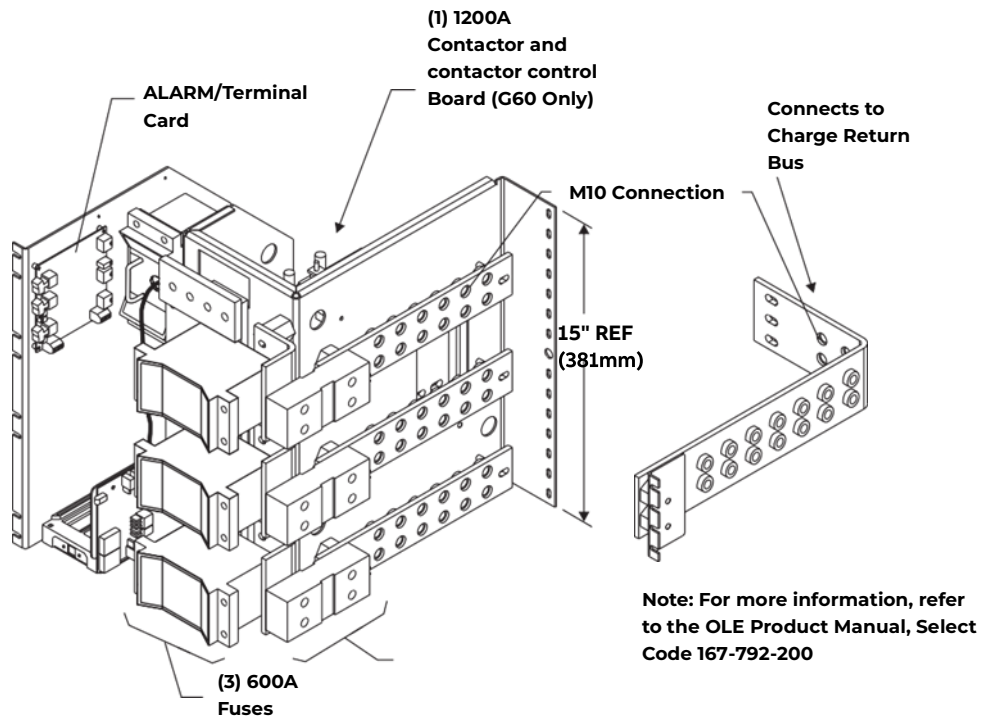

Figure 6-6: H569-434 G37/38 (ED83143-31 G60/61) Battery (OLE) Connection Panel

6 Battery Connection Panels (continued)

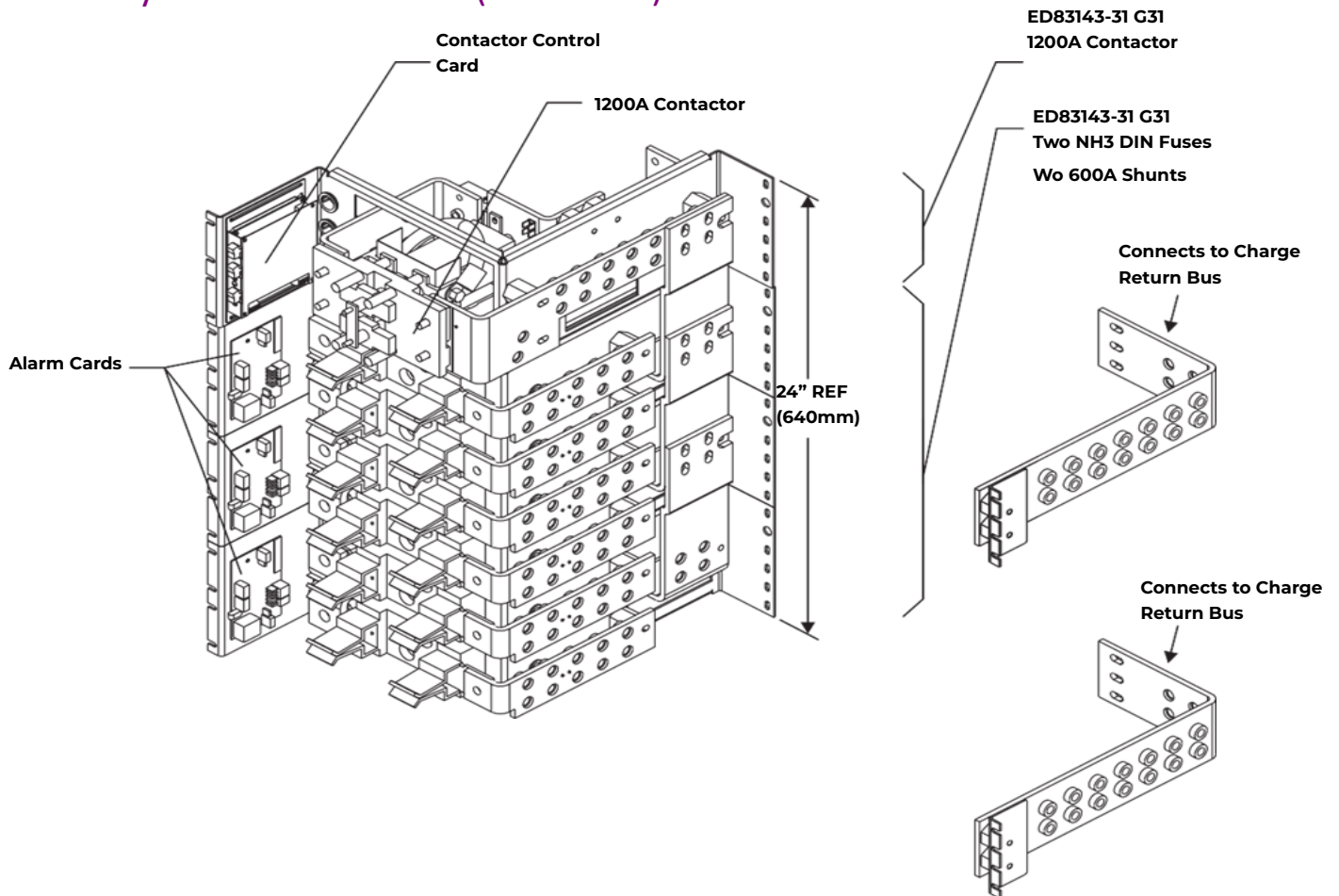

Figure 6-7: H569-434 G80/81/82 (ED83143-31 G31/43) Battery Connection Panel

H569-434	Includes:
G80	1 G31 1 G43
G81	1 G31 2 G43
G82	1 G31 3 G43 (shown)

6 Battery Connection Panels (continued)

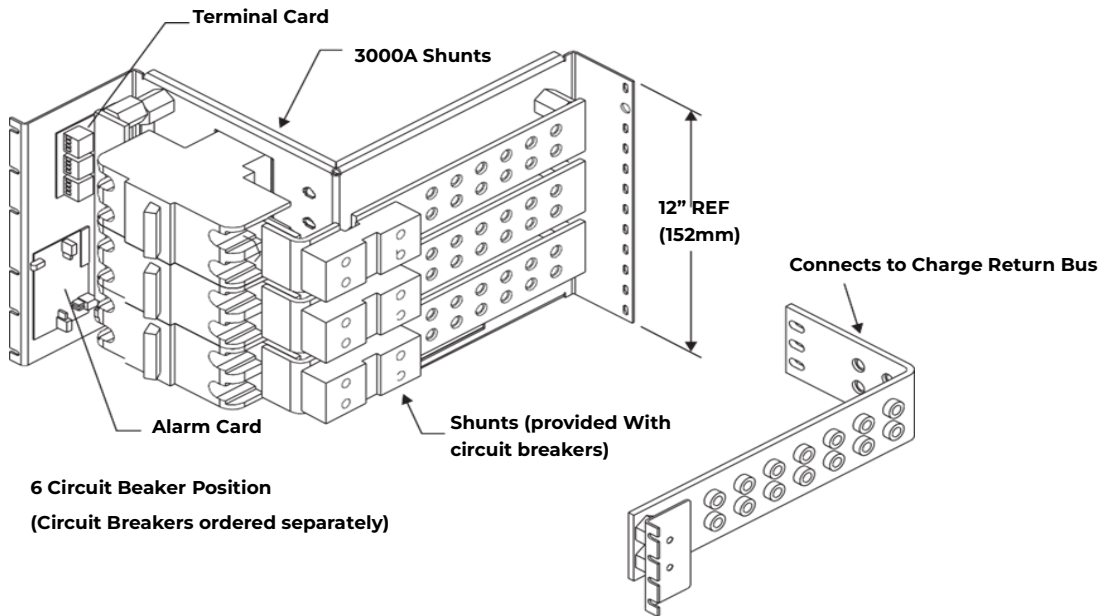

Figure 6-8: H569-434 G86/87 (ED83143-31 G63/64) Battery Connection Panel

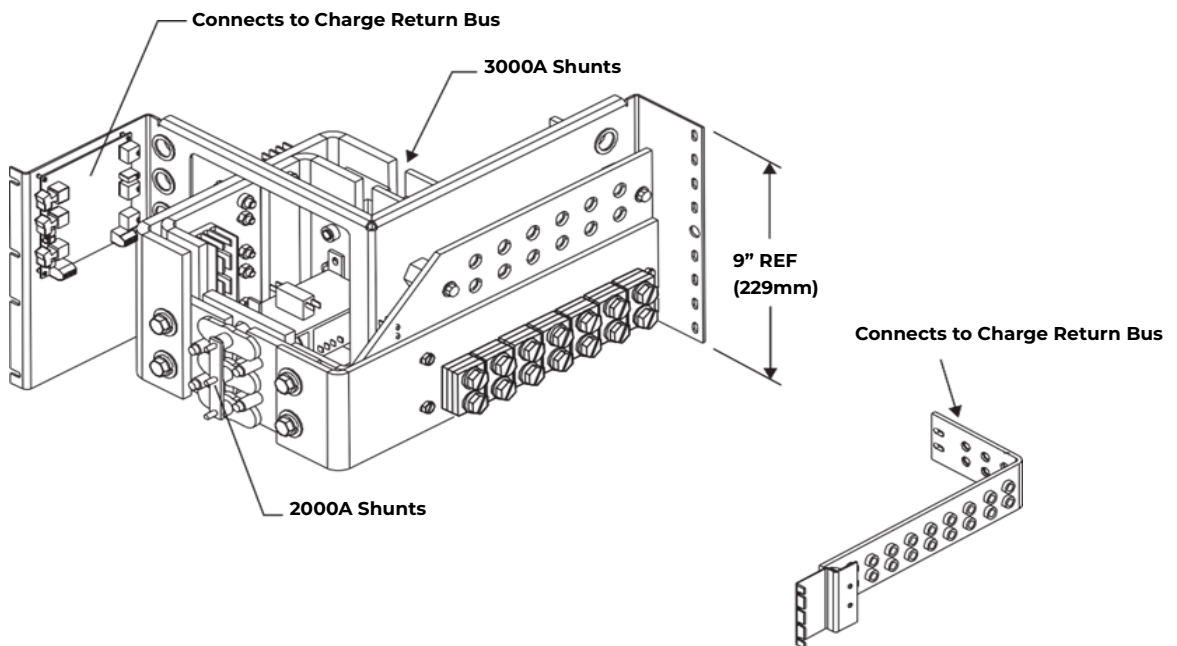

Figure 6-9: H569-434 G39 (ED83143-31 G36) Battery Connection Panel

This page intentionally left blank

7 DC Distribution Panels

Overview

Function

A variety of dc distribution panels are available featuring large or small fuses and circuit breakers of both domestic and European design. All panels are equipped with an alarm card. When a fuse operates or a circuit breaker trips, a red LED on the alarm card lights, the cabinet alarm lights, and the alarm is transmitted to the controller. Replacement fuses and plug-in circuit breakers are listed in the Replacement Parts section.

Illustrations

The dc distribution panels are illustrated in Figures 7-1 through 7-14.

Note: DC distribution panels are white; battery connection panels are blue.

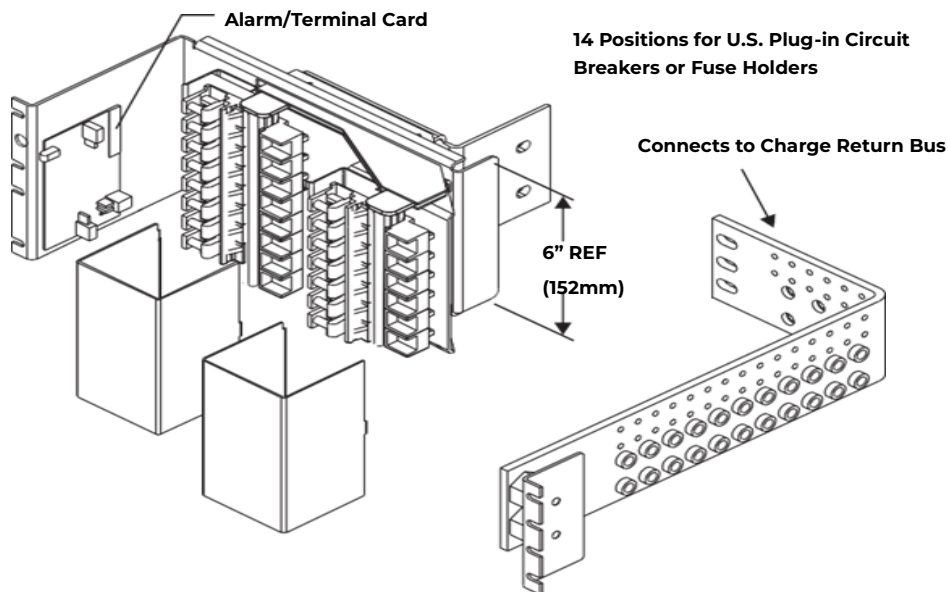

Figure 7-1: H569-434 G40/45/50/55 (ED83143-31 G11) 400A DC Distribution Panel

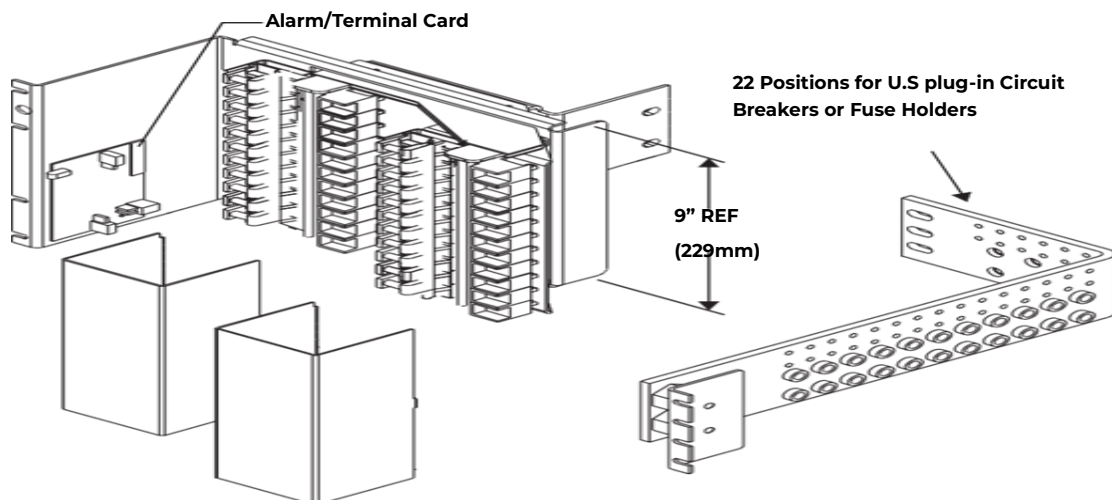

Figure 7-2: H569-434 G41/46/51/56 (ED83143-31 G12) 400A DC Distribution Panel

7 DC Distribution Panels (continued)

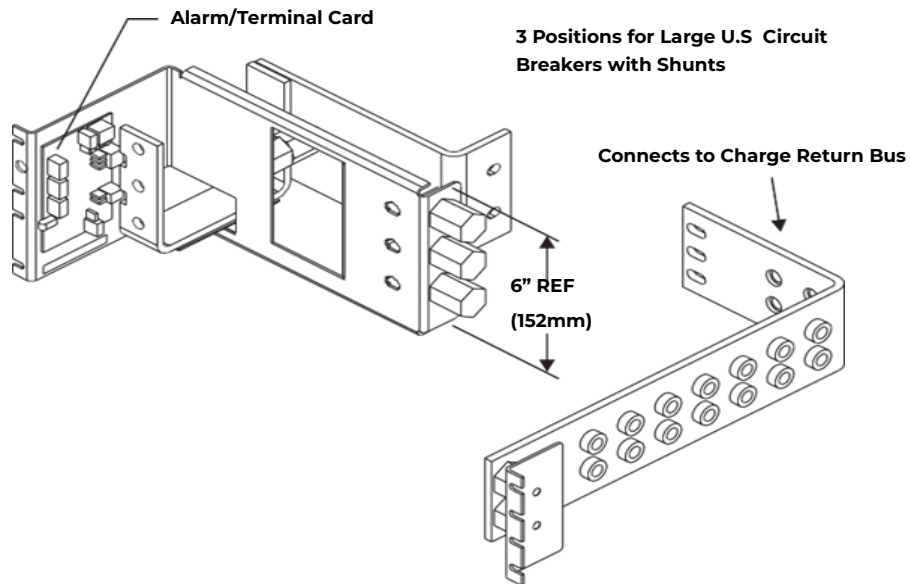

Figure 7-3: H569-434 G42/47 (ED83143-31 G2) 600A DC Distribution Panel

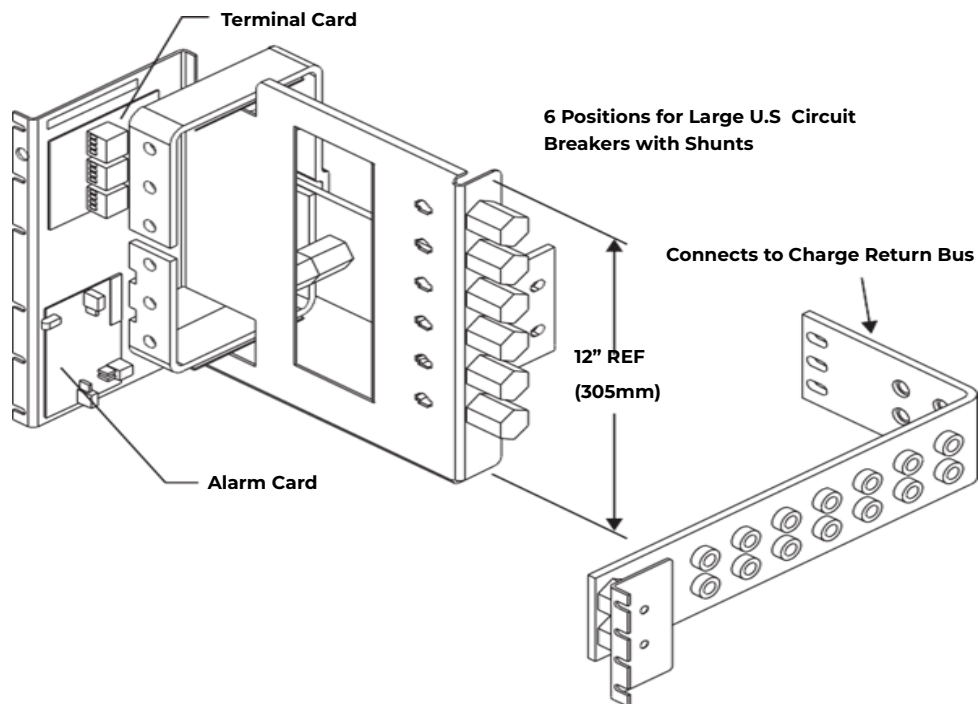

Figure 7-4: H569-434 G43 (ED83143-31 G1) 1200A DC Distribution Panel

7 DC Distribution Panels (continued)

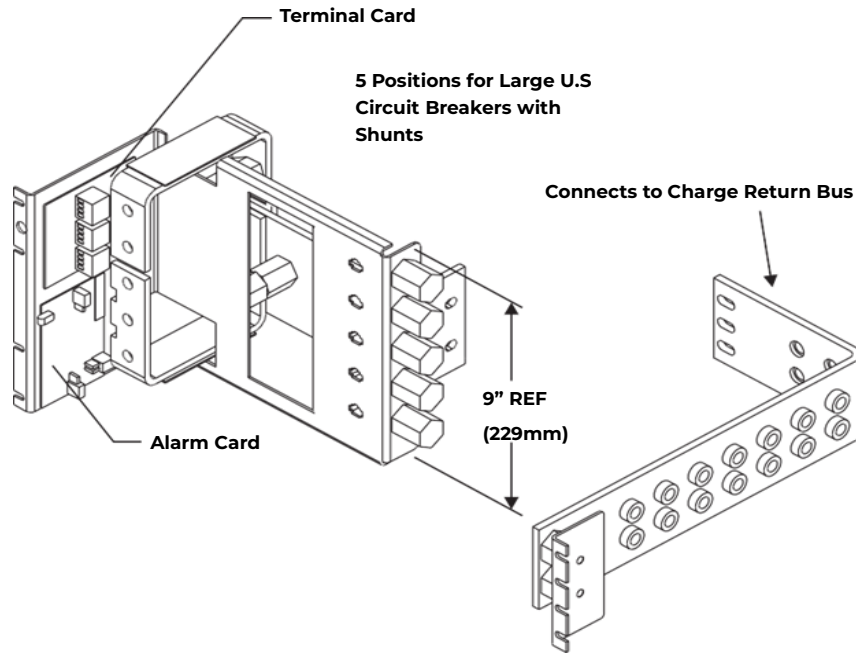

Figure 7-5: H569-434 G48 (ED83143-31 G5) 1000A DC Distribution Panel

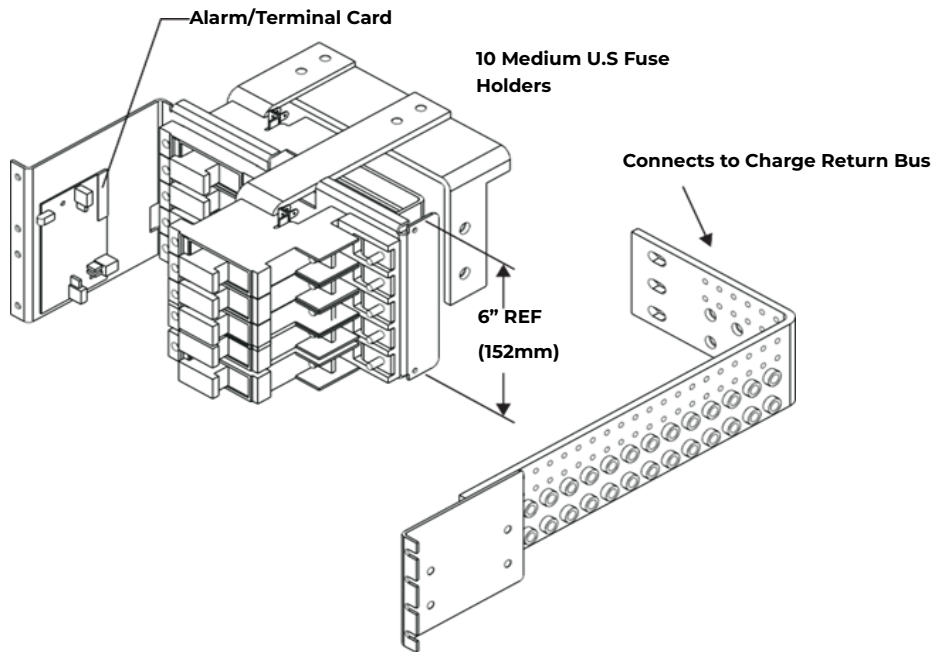

Figure 7-6: H569-434 G52 (ED83143-31 G53) 600A DC Distribution Panel

7 DC Distribution Panels (continued)

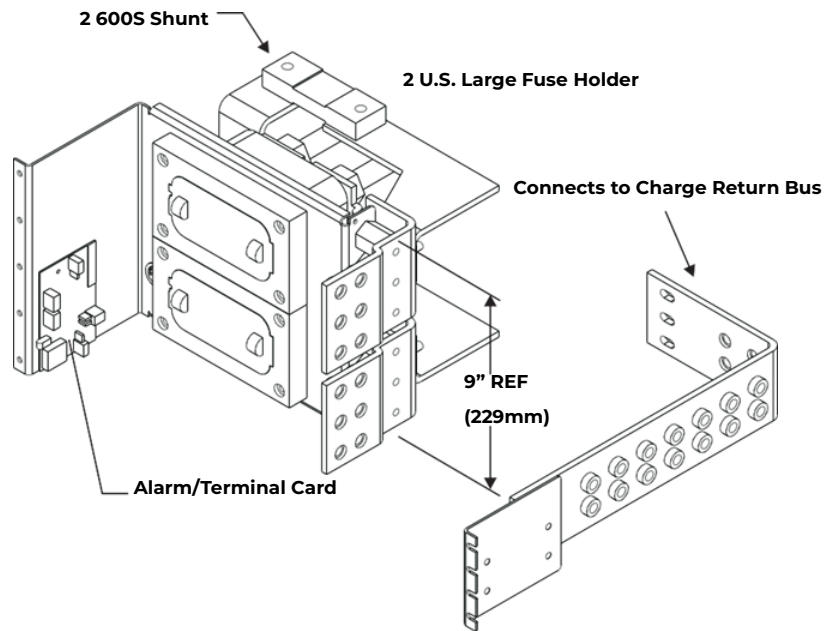

Figure 7-7: H569-434 G53/57 (ED83143-31 G55) 1000A DC Distribution Panel

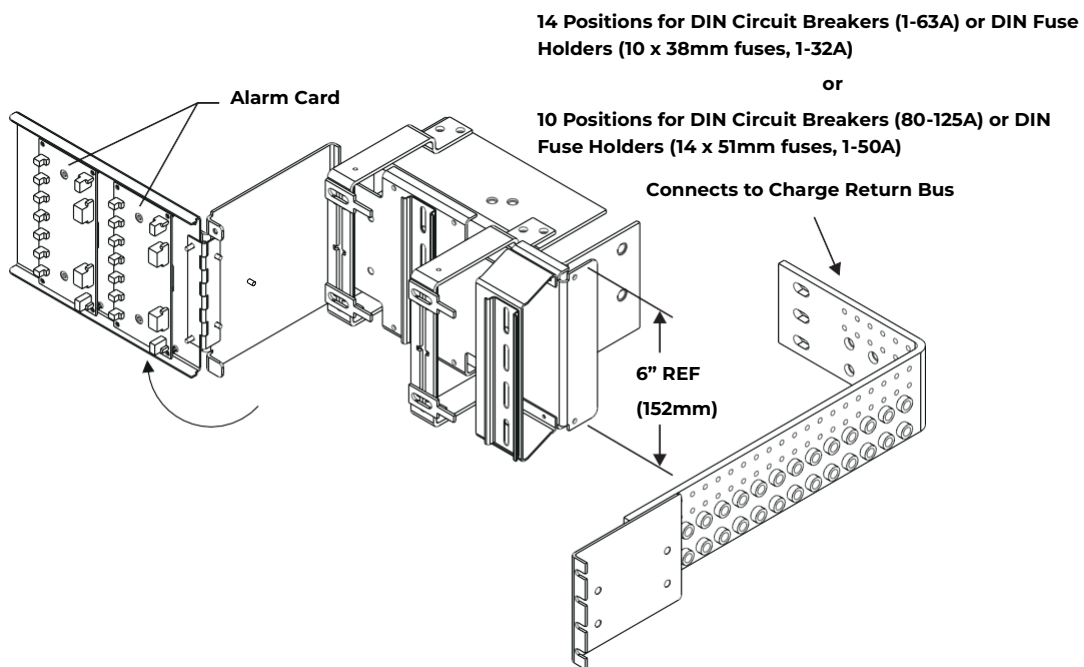

Figure 7-8: H569-434 G60/61/65/66 (ED83143-31 G71) 600A DC Distribution Panel

7 DC Distribution Panels (continued)

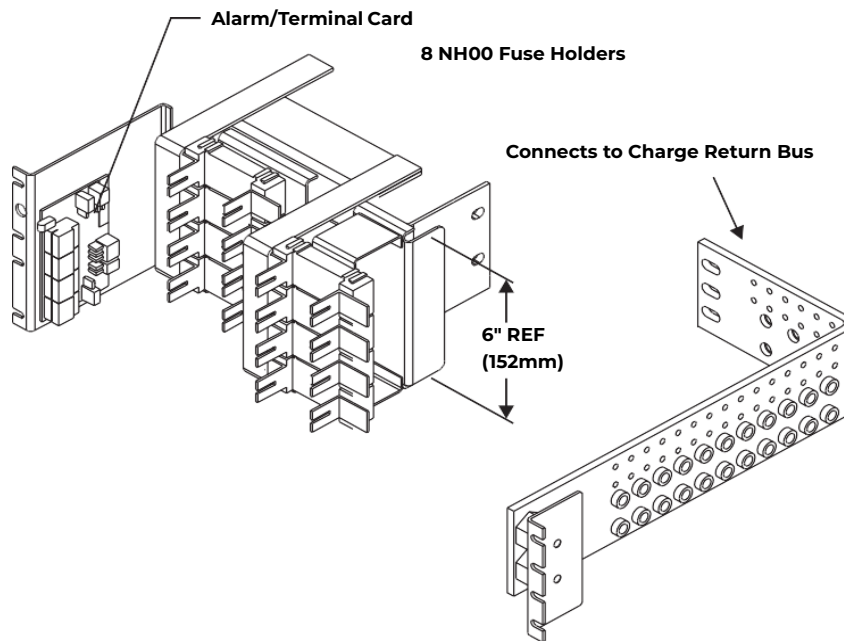

Figure 7-9: H569-434 G67 (ED83143-31 G22) 600A DC Distribution Panel

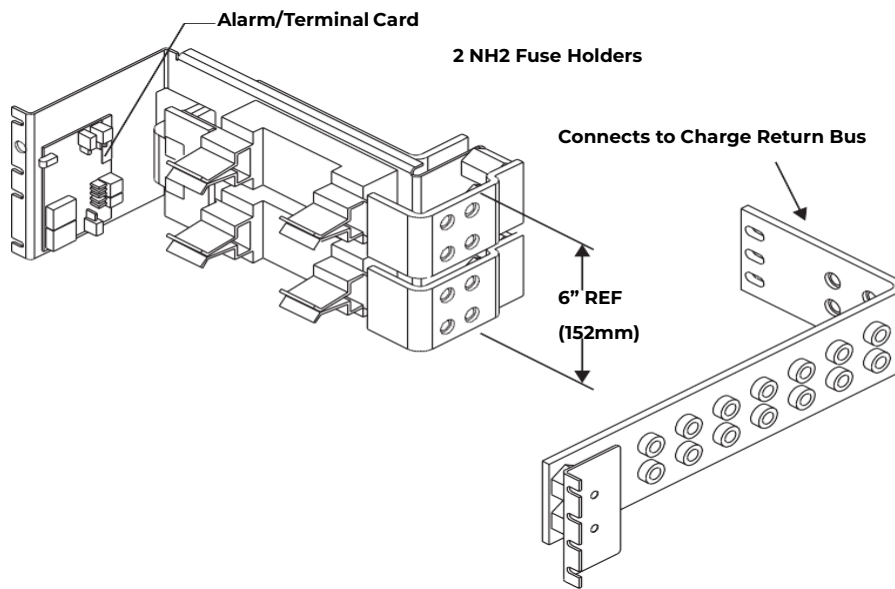

Figure 7-10: H569-434 G68 (ED83143-31 G21) 1200A DC Distribution Panel

7 DC Distribution Panels (continued)

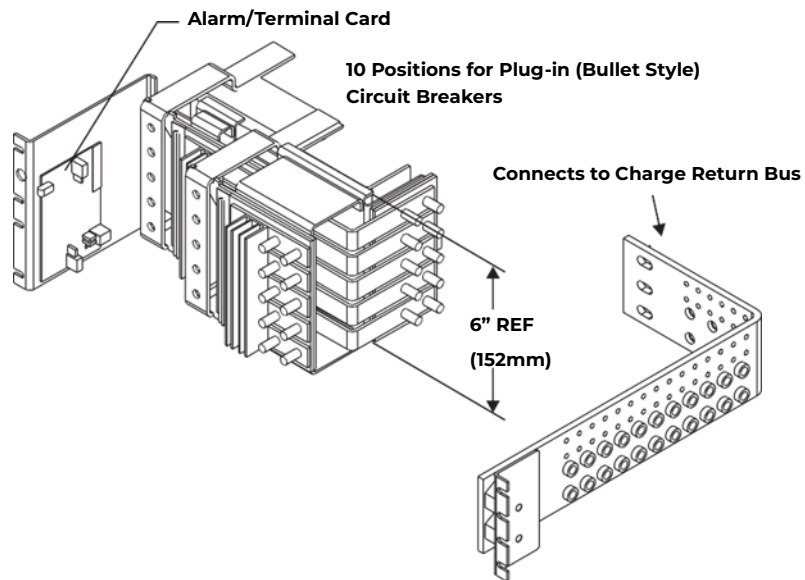

Figure 7-11: H569-434 G96 (ED83143-31 G15) 510A DC Distribution Panel

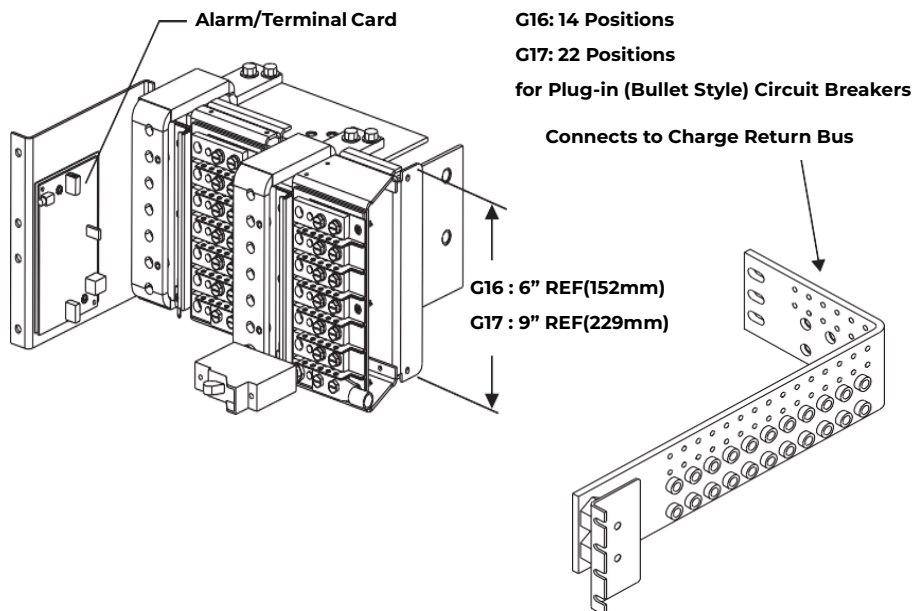

Figure 7-12: H569-434 G97 (ED83143-31 G16) 14-Position, and H569-434 G98 (ED83143-31 G17) 22-Position DC Distribution Panel

7 DC Distribution Panels (continued)

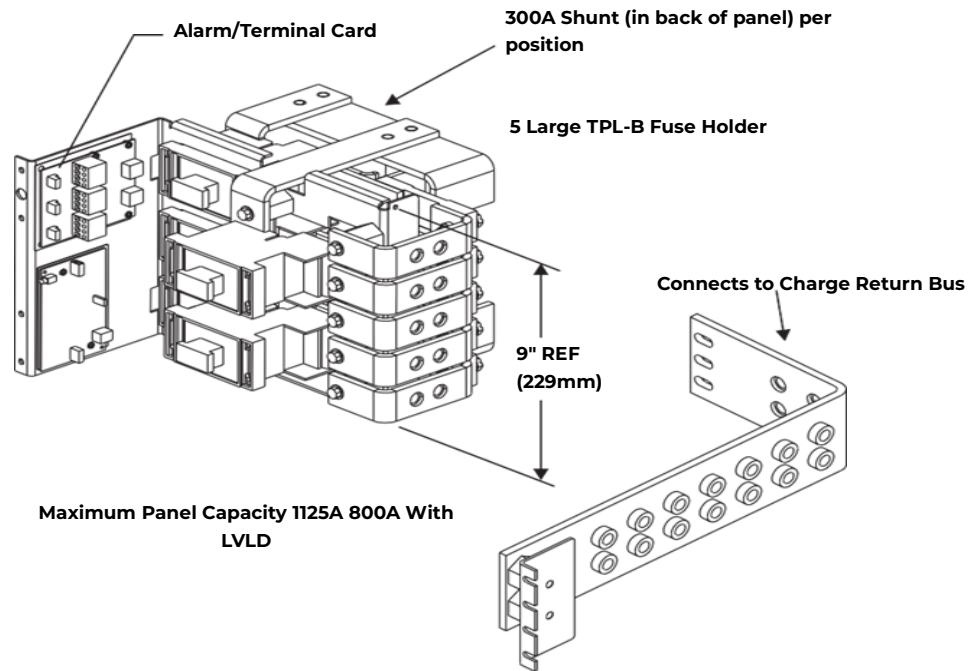

Figure 7-13: H569-434 G54 (ED83143-31 G54) 5-Position DC Distribution Panel

This panel mounts on the right side of the GPS cabinet and therefore takes up no space within the cabinet distribution area.

Maximum Panel Ampacity 15A per G58 Panel

6-Pin Jack for Power / Alarm Cable Set per 848665147

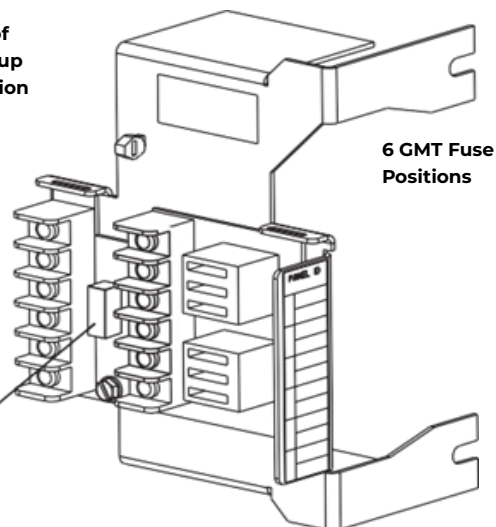

Figure 7-14: H569-434 G58 (ED83143-31 G58) 6-Position GMT DC Distribution Panel

7 DC Distribution Panels (continued)

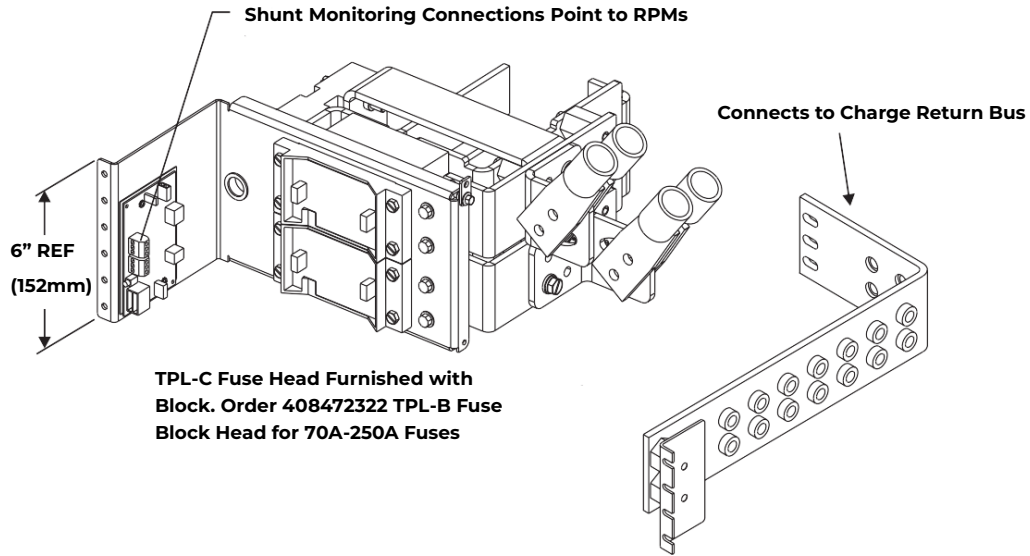

Figure 7-15: H569-434 G59 (ED83143-31 G56) 2-Position Fuse Distribution Panel

8 Circuit Boards

Overview

Function

Circuit boards (sometimes referred to as “cards” or “circuit packs”) are included in bays, battery connection panels, and dc distribution panels to provide data required by the controller and to control devices such as contactors and lamps.

Terminal Boards

Terminal boards are used to provide shunt voltage data to the controller, where it is used to calculate current. Data from the terminal boards located on the battery connection panels are used to calculate battery current; data from terminal boards located on the dc distribution panels are used to calculate load currents.

Alarm Boards

Alarm boards perform two functions:

- monitor panel functions and activate local indicators when faults occur on the panel;
- provide alarm data to the controller.

Alarm/Terminal Boards

Alarm/terminal boards combine the functions of alarm boards and terminal boards.

BLJ Terminal Board

The BLJ terminal board is located inside the cabinet door. The BLJ is the termination point for all signal cables in each cabinet and between cabinets.

Bay Interface Card

Each cabinet has a Bay Interface Card (BIC) that attaches to the cabinet’s terminal board (BLJ). The BIC provides controller access to alarm monitoring, battery voltages, battery currents, and temperature probes in the cabinet through the serial rectifier bus. The BIC also provides connection of the system serial rectifier bus to the bay rectifiers. See Figure 1-1.

Contactors Control Board

Contactors control boards provide four functions:

- Monitor and report shunt voltage to the controller
- Monitor and report contactor status to the controller
- Operate the contactor based on controller commands
- Operate or block the contactor based on maintenance switch settings

This page intentionally left blank

9 Specifications

GPS 4848/100

Electrical	
Nominal output voltage	-48Vdc
Operating Voltage Range (Float or Boost)	-44Vdc to -58Vdc
Output Current (System Maximum)	14,080A
Nominal Input Voltage (595LTA or 595A3 Rectifier)	380-480Vac, 3-wire plus ground
Nominal Input Voltage (595LTB or 595B3 Rectifier)	200-240Vac, 3-wire plus ground
Input Voltage Range per phase(595LTA or 595A3 Rectifier)	320Vac - 530Vac
Input Voltage Range per phase(595LTB or 595B3 Rectifier)	176Vac - 254Vac
Input Frequency Range	47 Hz - 63 Hz
System Efficiency (including ac and dc cables)	>88%
Regulation (line and load range with controller)	± 0.5%
AC Ripple	<100mVrms
Output Noise	<2mV psophometric
Electromagnetic Immunity	10V/meter over 20 MHz - 2000 MHz

Table 9-A: Galaxy Power System 4848/100 Specifications

Physical	
Width, Depth	600 mm, 600 mm (23.6 in. x 23.6 in.)
Weight (approximate, per cabinet)	250 kg (551 lbs.)
Height (cabinet only)	2134 mm (84.0 in.)
Height (cabinet with link bus bar)	2274 mm (89.5 in.)
Environmental	
Heat Release, per cabinet	at 54Vdc, 220Adc
Number of Rectifiers 4	595A / LTA 595B / LTB
5	4,120W (14,100 BTU / hr) 4,720W (16,100 BTU / hr)
6	5,150W (17,600 BTU / hr) 5,900W (20,200 BTU / hr)
7	6,180W (21,100 BTU / hr) 7,080W (24,200 BTU / hr)
8	7,210W (24,600 BTU / hr) 8,260W (28,200 BTU / hr)
12	8,240W (28,100 BTU / hr) 9,440W (32,200 BTU / hr)
14	12,360W (42,200 BTU / hr) 14,200W (48,300 BTU / hr)
per Rectifier	14,420W (49,200 BTU / hr) 16,500W (56,400 BTU / hr)
	1,030W (3,520 BTU / hr) 1,180W (4,050 BTU / hr)
Operating Temperature	0°C to 40°C
Operating Relative Humidity	5% - 95%
Units Per Initial Cabinet	
Rectifiers	595LTA / 595LTB: 0 - 12; 595A / 595B: 0 - 6
Controller	1
Battery Modules	0 - 3
DC Distribution	1 - 6 (maximum of 5 with battery disconnect)
Units Per Growth Cabinet	
Rectifiers	595LTA / 595LTB: 0 - 14; 595A / 595B: 0 - 7
Battery Modules	0 - 1
DC Distribution	1 - 6 (maximum of 5 with battery disconnect)

Table 9-A: Galaxy Power System 4848/100 Specifications (Continue)

9 Specifications (continued)

Standards Compliance	
Safety	<ul style="list-style-type: none"> UL³ Listed (US and Canada): UL Subject 1801 with applicable sections of UL1950/CSA⁴950 VDE Licensed to VDE 0805/IEC950/EN60950 <p>³UL is a registered trademark of Underwriters Laboratories, Inc. ⁴CSA is a registered trademark of Canadian Standards Association.</p>
Electromagnetic Compliance	<ul style="list-style-type: none"> Emission: <ul style="list-style-type: none"> FCC Part 15 Class B EN55022 (CISPR 22) Radiated/Conducted Emission, Class B Immunity <ul style="list-style-type: none"> IEC/EN 61000-4-2 ESD levels 3 and 4 IEC/EN 61000-4-3 Radiated Immunity, 10V/m IEC/EN 61000-4-4 Electrical Fast Transients/Burst, level 4 IEC/EN 61000-4-5 Lightning Surge, level 4
CE Marking	<ul style="list-style-type: none"> CE marked per European Union Council Directives: <ul style="list-style-type: none"> Low-Voltage Directive (73/23/EEC) EMC Directive (89/336/EEC) as amended by CE Marking Directive (93/68/EEC)
Telcordia	<ul style="list-style-type: none"> GR-63 and GR-1089 NEBS (including Level 3 testing) Report by an independent test house

Table 9-A: Galaxy Power System 4848/100 Specifications (continued)

Rectifiers

Electrical			
Output Voltage	52Vdc typical		
Output Voltage Adjustment	44-58Vdc float/boost		
Regulation (with controller)	±0.5%		
Output Current	595LTA	595LTB	
	220A	0°C to 40°C	0°C to 37°C at
	50°C	200A	200A
High Voltage Shutdown (selected by controller)	Float/boost 44-60Vdc (56Vdc default)		
Backup High Voltage Shutdown	Float/boost 59-60Vdc (59.5Vdc nominal)		
Ripple	100mVrms		
Noise	<2mV psophometric		
Current Limit Set Point	60Adc - 220Adc		
	595LTA Rectifier	595LTB Rectifier	
Nominal Input Voltage (3-wire plus ground)	380 - 480 Vac	200 - 240 Vac	
Input Voltage Range (per phase)	320 - 530 Vac	176 - 275Vac	
Input Current	Specified	20A at 480Vac	40A at 208Vac
		25A at 380Vac	35A at 240Vac
	Rated Maximum	30A	50A
	Typical Maximum	23.7A at 320Vac	44.1A at 176Vac
		20.4A at 380Vac	38.8A at 200Vac
		16.2A at 480Vac	37.3A at 208Vac
			32.3A at 240Vac
Frequency Range	47 - 63 Hz		
Power Factor	0.98 from 50% to 100% load		
Total Harmonic Distortion	<5% from 50% to 100% load		

Table 9-B: 595LT Series Rectifier Specifications

9 Specifications (continued)

AC Surge Protection: It is important that ac surges reaching rectifiers do not exceed the capacity of the rectifier internal surge protection. Protection must be provided external to the GPS system to limit surge energy reaching the rectifiers. Site surge protection must be coordinated with rectifier internal surge protection and must clamp at a lower voltage than the rectifier internal protection. The internal protection voltage and current characteristics of the rectifiers are as follows:

595LTA

Phase to Phase MOV Conduction

<u>Voltage</u>	<u>Current</u>
625 Vac (RMS)	0 A
940 Vpeak	1 mA
1650 Vpeak	100 A

595LTB

Phase to Phase MOV Conduction

<u>Voltage</u>	<u>Current</u>
320 Vac (RMS)	0 A
462 Vpeak	1 mA
810 Vpeak	100 A

Table 9-B: 595LT Series Rectifier Specifications (continued)

Physical	
Width	265 mm (10.4 in.) rear of unit
Height	210 mm (8.25 in.) rear of unit
Depth	470 mm (18.2 in.) overall, less connector
Weight	21.5 kg (47.5 lbs)
Environmental	
Efficiency	From 100Adc to 220Adc 595LTA 595LTB >92% >90%
Storage Temperature	-40°C - +85°C
Storage Relative Humidity	5% - 90%
Altitude	-50 to 4000 meters (Note: For altitudes above 1500 meters, derate the temperature by 0.656° Celsius per 100 meters.)
Audible Noise	< 60dBA at room temperature, mounted in cabinet
Heat Release per Rectifier:	595LTA 595LTB
54Vdc, 160Adc	750W (2,560 BTU / hr) 830W (2,800 BTU / hr)
54Vdc, 200Adc	940W (3,200 BTU / hr) 1,100W (3,800 BTU / hr)
54Vdc, 220Adc	1,000W (3,520 BTU / hr) 1,300W (4,500 BTU / hr)
Standards Compliance	
Safety	<ul style="list-style-type: none"> UL Recognized (US and Canada) and VDE UL1950, EN60950/IEC950, and CSA 234/950 (tested for SELV Output)
Electromagnetic Compliance: Emission and Immunity	<ul style="list-style-type: none"> EN55022 (CISPR22) Radiated/conducted emission, Class B meets FCC Part 15 Class B IEC/EN 61000-4-2 ESD levels 3 and 4 IEC/EN61000-4-3 Radiated Immunity, 10Vm IEC/EN61000-4-4 Electrical Fast Transients/Burst, level 4 IEC/EN 61000-4-5 Lightning Surge, level 4
CE Marking	CE marked per European Union Council directives: Low-voltage Directive (73/23/EEC) as amended by CE Marking Directive (93/68/EEC)

Table 9-B: 595LT Series Rectifier Specifications (continued)

9 Specifications (continued)

State	Display Message	LED Illuminated
Normal	Current	On
Output Limited	Current	LIM
Manual Standby	Blank	STBY
Remote Standby (Shutdown)	tr	STBY
Output Breaker Open	CB	ALM
Interlock Open	ILC	ALM
AC Fail	ACF	None
Phase Fail	PF	None
Over Temperature Shutdown	tA	ALM
Output Under Voltage Shutdown	LO	ALM
High Voltage Shutdown	HO	ALM
Internal Failure	LS, ICS, IP5, IP6, IP7, SEN, FSE, InF	ALM

Table 9-C: Rectifier Display Messages and LEDs

AC Input Panels

	Vac	AC Feeds	Rectifiers	ED83142-30	H569-434GPS4848/100
AC Circuit Breaker Panels - 595 Rectifiers					
	208/240	2	4	3	20, 220
	208/240	2	6	4	21
	480	1	4	2	22
	480	2	6	4	23
65KIC	480	2	4	10	70, 270
65KIC	480	2	6	11	71
AC Terminal Strip Panels- 595 Rectifiers					
	208/240	4	4	5	24, 224
	208/240	6	6	5	25
	208/240	8	8	18	129, 131
	480	4	4	5	26, 226
	480	6	6	5	27
	480	8	8	18	128, 130
AC Circuit Breaker Panels - 595LT Rectifiers					
	208/240	2	4	3	320, 420
	208/240	2	6	4	321, 421
	208/240	4	12	25	335
	480	1	4	2	322
	480	2	6	4	323
	480	4	12	24	334
65KIC	480	2	4	10	370, 470
65KIC	480	2	6	11	371, 471
AC Terminal Strip Panels - 595LT Rectifiers					
	208/240	4	4	5	324
	208/240	6	6	5	325
	208/240	8	8	18	331
	208/240	12	12	26	329
	208/240	14	14	26	333
	480	4	4	5	326
	480	6	6	5	327
	480	8	8	18	330
	480	12	12	26	328
	480	14	14	26	332
Distribution Only Panels, no ac					
		-		None	28
		-		None	29

Table 9-D: AC Panels

9 Specifications (continued)

Battery Connection Panels

Fuse or Circuit Breaker	LVBD	Shunt	ED83143-31	H569-434 GPS4848/100
No Battery Panel				
			None	33
Panels without Fuses or Circuit Breakers				
		1,500A	30	32
		3,000A	30A	32A
	2,000A	3,000A	36	39
	1,200A	1,500A	31	31
	2 x 500A	2 x 600A	32	30
Panels with Fuses or Circuit Breakers				
2 x NH3 fuse		2 x 600A	41	34
1 x NH3 fuse		600A	42	35
2 x NH3 fuse	1,200A	2 x 600A	43 with 31	80
4 x NH3 fuse	1,200A	4 x 600A	2 x 43 with 31	81
6 x NH3 fuse	1,200A	6 x 600A	3 x 43with 31	82
6 x breaker poles			63	86
6 x breaker poles	800A		64	87
Off Line Equalize Panels				
	1,200A	3 x 1,000A	60	37
		3 x 1,000A	61	38

Table 9-E: Battery Connection Panels

9 Specifications (continued)

DC Distribution Panels

Fuse or CB	Pos	Height(in.)	LVL D	Shunt	ED83143-31 Group ¹	H569-434 GPS 4848/100 Group ¹
CB Clip-on / Fuse Small - TPA	14	6			11	40, 40A, 50, 50A
CB Clip-on / Fuse Small - TPA	14	6	Y		11	45, 45A, 55, 55A
CB Clip-on / Fuse Small - TPA	22	9			12	41, 41A, 51, 51A
CB Clip-on / Fuse Small - TPA	22	9	Y		12	46, 46A, 56, 56A
CB Large – Bolt-in	3	6		CB size, 25mV	2	42, 42A, 106, 106A, 107, 107A, 108, 108A, 109, 109A
CB Large – Bolt-in	3	6	Y	CB size, 25mV	2	47, 47A
CB Large – Bolt-in	5	9		CB size, 25mV	5	48, 48A, 110, 110A, 111, 111A, 112, 112A, 113, 113A
CB Large – Bolt-in	5	9	Y	CB size, 25mV	5	48B, 48C
CB Large – Bolt-in	6	12		CB size, 25mV	1	43, 43A, 101, 101A, 102, 102A, 103, 103A, 104, 104A
CB Large – Bolt-in	6	12	Y	CB size, 25mV	1	43B, 43C
CB Bullet	10	6			15	96, 96A
CB Bullet	10	6	Y		15	96B, 96C
CB Bullet	14	6			16	97, 97A
CB Bullet	14	6	Y		16	97B, 97C
CB Bullet	22	9			17	98, 98A
CB Bullet	22	9	Y		17	98B, 98C
Fuse Medium - TPS	10	6			53	52, 52A
Fuse Medium - TPS	10	6	Y		53	52B, 52C
Fuse Large	2	6		1500A, 50mV 1 / fuse	56, 56A	59, 59A
Fuse Large - TPL	2	9		600A, 50mV 1 / fuse	55	53, 53A
Fuse Large - TPL	2	9	Y	600A, 50mV 1 / fuse	55	57, 57A
Fuse Large - TPL-B	5	9		300A, 50mV 1 / fuse	54	54, 54A
Fuse Large - TPL-B	5	9	Y	300A, 50mV 1 / fuse	54	54B, 54C
CB DIN Small	14	6			71/171	60, 60A
CB DIN Small	14	6	Y		71/171	60B, 60C
CB DIN Large	10	6			71/171	61, 61A
CB DIN Large	10	6	Y		71/171	61B, 61C
Fuse DIN 10 x 38mm	14	6			71/171	65, 65A
Fuse DIN 10 x 38mm	14	6	Y		71/171	65B, 65C
Fuse DIN 14 x 51mm	10	6			71/171	66, 66A
Fuse DIN 14 x 51mm	10	6	Y		71/171	66B, 66C
Fuse DIN NH00	8	6			22	67, 67A
Fuse DIN NH00	8	6	Y		22	67B, 67C
Fuse DIN NH2	2	6			21	68, 68A
Fuse DIN NH2	2	6	Y		21	68B, 68C
Small Fuse, 6-GMT	6	0			58	58
Blank Panel	-	3			JD	93
Blank Panel	-	6			JA	90
Blank Panel	-	9			JB	91
Blank Panel	-	12			JC	92

Table 9-F: DC Distribution Panels

- Groups with B suffix or no suffix include return bus.
Groups with A or C suffix and Blank Panels do not include return bus.

10 Safety

Please read and follow all safety instructions and warnings before servicing the GPS 4848/100. Reference the Safety section of the GPS Installation Guide and individual module product manuals for safety statements specific to the modules.

11 Maintenance and Replacement

Requirements

System

With the exception of the battery, periodic maintenance specific to the power system is not required. The ac service for the building must be maintained with ANSI specified limits. The temperature and humidity within the power room must be maintained within the limits specified in Section 9 of this product manual.

Refer to Table 11-A for system replacement parts.

Batteries

The batteries must be maintained as directed by the battery manufacturer's requirements.

Controller

For replacement circuit packs for the Galaxy Millennium Controller, refer to Table 11-B.

Rectifier

With the exception of a fan failure, rectifiers are repaired by replacement.

Refer to "Installing or Replacing a Rectifier" and "Removing a Rectifier" in this section.

Vacant Rectifier Positions

Vacant rectifier position below or beside the top installed rectifier in this cabinet may cause over-heating of the installed rectifiers. Immediately install a replacement rectifier or a Rectifier Shelf Cover / Air Dam into the vacated position.

Rectifier Shelf Cover(848680211)	Covers both left and right rectifier positions
Air Dam (CC848809178)	Covers the left or right rectifier position

Rectifier Fan Assembly

The expected life of the rectifier fans at 25 °C (77°F) is approximately seven years. The fans in the rectifiers may be replaced in the field.

Two approaches can be taken to fan maintenance:

- The first approach is to replace the two fans on a routine basis every six to seven years; this ensures that the fans do not fail in the field under normal operating conditions. This approach is appropriate when there are no remote alarm facilities at the site.
- The second approach, assuming one has remote alarm capability, is to wait until the fans fail. The rectifier will safely shut down and issue both a fail alarm and a fan alarm. The two fans can then be replaced. Since it is likely that all the rectifiers in that installation are of roughly the same age, all rectifier fans at that site should be replaced at that time.

The approach used depends on the location and manning of the site as well as the monitoring of alarms used at the site.

Refer to "Replacing the Rectifier Fan Assemblies" in this section.

Replacement Procedures

Installing or Replacing a Rectifier

Stop! Be sure rectifier is set to STBY and ac breakers on cabinet are OFF!

Installing or Replacing a Rectifier	
Step	Action
1	Unpack the rectifier from shipping container. <div style="text-align: right;"> Caution Rectifier is heavy (47.5 pounds). Use two people to lift and move rectifiers. </div>
2	Remove rectifier by lifting the unit in a vertical direction from the packing container. See figure below. <div style="text-align: right;"> Caution Do not rest rectifier on faceplate or rear chassis; damage to faceplate and/or rear busbars will occur, rendering the unit unusable. </div>
Continued on next page	

Replacement Procedures (continued)

Installing or Replacing a Rectifier, continued	
Step	Action
3	Turn ac circuit breaker OFF.
4	Place rectifier power switch in STBY.
5	<p>Install the rectifier. See Figure 11-1.</p> <ul style="list-style-type: none"> Verify that the output circuit breaker is OFF and that the rectifier power switch is in the "Standby" position. Slide the unit slowly onto the shelf until it contacts the rearconnector. <p>Note: Install rectifiers, starting at the bottom left position and working to the right, and then upward.</p> <p style="text-align: center;"> Caution</p> <p>Verify that the rectifier chassis slides rearward evenly on the left and right sides as the locking screw is turned. DO NOT USE EXCESSIVE FORCE DURING THIS PROCEDURE! If the rectifier-to-shelf mating process appears to bind, back the unit out and start over. Avoid stripping the threads of the locking screw by stopping when the rearward progress of the rectifier ceases.</p>

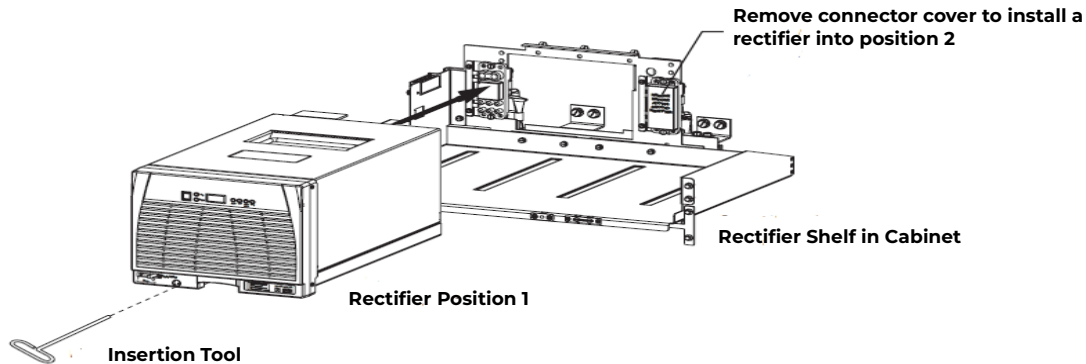



Replacement Procedures (continued)

Installing or Replacing a Rectifier, continued	
Step	Action
6	Turn ON output circuit breaker.
7	Turn ON ac circuit breaker.
8	Turn rectifier power switch to ON position.
9	Verify: <ul style="list-style-type: none"> • Green LED is illuminated. • No alarms are illuminated.
10	Set rectifier ID number as follows: <ol style="list-style-type: none"> Depress rectifier power switch in UP position; rectifier ID is displayed. Hold rectifier power switch in UP position for 5 seconds; the display number will begin to blink. Release the switch. Depress and hold the switch for 3 seconds to rapidly advance the ID. Depress and release repeatedly until the desired ID is reached. Leave switch un-pressed for 10 seconds to save the ID number.
11	Follow Steps 3-5 to install remaining rectifiers. Follow Steps 6-10 to set remaining ID numbers.
12	Verify that the system voltage reads 52.08V or desired float voltage.
13	Test replaced rectifiers using the "Testing Additional Alarms After Replacement of Rectifiers" procedure in this section



Removing a Rectifier

Removing a Rectifier					
Step	Action				
1	Set power switch to STBY.				
2	Turn OFF ac circuit breakers.				
3	Turn OFF output circuit breaker on rectifier.				
4	 Wait 5 minutes to allow capacitors to discharge.				
5	Using a 5mm Allen-head "T" wrench, slowly turn the locking screw counter clockwise to release the rectifier from the shelf.				
6	Slowly slide rectifier from shelf.  Caution Rectifier is heavy (47.5 pounds). Use two people to lift and move rectifiers. Do not rest rectifier on faceplate or rear chassis; damage to faceplate and/or rear busbars will occur, rendering the unit unusable.				
7	If the rectifier is not going to be replaced immediately, retire the active CMA (Communications Fail - Minor) against that rectifier ID by using the following path on the Configuration menu on the front display of the plant controller: Menu -> CONFIG -> RECT MNGR (Basic Controller) or Menu -> CONFIG -> RECT MNGR -> RECT OPER (Intel Controller) Move to the Field REMOVE RECT and use the (+) key to input the Rectifier ID of the removed rectifier. Press Enter to clear the alarm.				
8	If the removal of the rectifier results in a vacant rectifier position below or beside the top installed rectifier in this cabinet, it must be replaced immediately or the vacated position must be occupied by a Rectifier Shelf Cover or Air Dam. <table border="0" style="width: 100%;"> <tr> <td style="width: 20%;">Rectifier Shelf Cover (84-8680211)</td> <td>Covers both left and right rectifier positions</td> </tr> <tr> <td>Air Dam (CC848809178)</td> <td>Covers the left or right rectifier position</td> </tr> </table>	Rectifier Shelf Cover (84-8680211)	Covers both left and right rectifier positions	Air Dam (CC848809178)	Covers the left or right rectifier position
Rectifier Shelf Cover (84-8680211)	Covers both left and right rectifier positions				
Air Dam (CC848809178)	Covers the left or right rectifier position				

Replacement Procedures (continued)

Replacing the Rectifier Fan Assemblies

Replacing the Rectifier Fan Assemblies	
Step	Action
1	Follow instructions in the “Removing a Rectifier” procedure in this section. Refer to Figure 11-1.
2	Place rectifier on a flat surface at a comfortable working height.
3	Loosen the front cover (white) by removing 4 screws (2 on each side). Remove the cover and place it next to the rectifier. See Figure 11-2.  Caution Allow the front end of the rectifier to overhang the working surface.

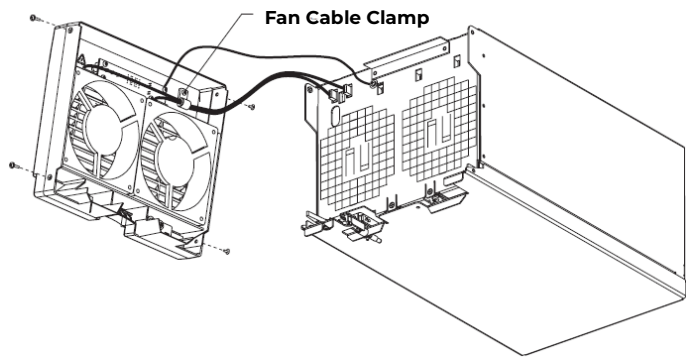

Figure 11-2: Rectifier Faceplate Assembly

Replacing the Rectifier Fan Assemblies, continued	
Step	Action
4	Carefully unplug the fan connectors (2). The fan connector is keyed and can be loosened by inserting a screwdriver into the slotted side of the connector and gently prying the fan-side connector loose.
5	Remove the fan cable clamp.
6	Place the new fans in position with their cables positioned as shown in Figure 11-3.
7	Replace the fan cable clamp.
8	Replace the front cover.
9	Install the rectifier, following the “Installing or Replacing a Rectifier” procedure in this section.
10	Test replaced rectifiers using the “Testing Additional Alarms After Replacement of Rectifiers” procedure in this section.

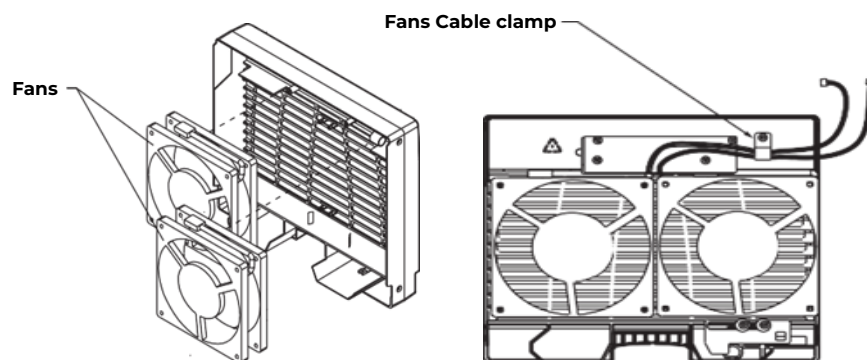

Figure 11-3: Rectifier Fan Assembly

Testing

Note: Consult the GPS Installation Guide for complete testing guidelines for new installations. Alarm LEDs refer to the controller unless otherwise noted.

Testing Additional Alarms After Replacing Rectifiers

Alarm operation may be verified while the system operates at float voltage.

Testing Additional Alarms After Replacing Rectifiers	
Step	Action
1	Turn OFF the ac circuit breaker of replaced rectifier. Verify that AC and MIN alarm LEDs illuminate, the rectifier displays ACF, and the controller alarms screen indicates ACFAIL: Gmm.
2	Turn ON the ac circuit breaker of the replaced rectifier. Verify that the rectifier starts and the alarms retire.
3	Turn OFF the DC Output CB at the bottom left of the rectifier. Verify that the Rectifier and Minor alarm LEDs illuminate, the rectifier displays Cb, and the controller alarms screen indicates RECTIFIER FAIL: Gmm.
4	Turn ON the DC Output CB of the rectifier. Verify that the rectifier picks up load similar to others in the system and that the alarms retire.

Testing Rectifiers and Load Share in Bay Expansions

Testing Rectifiers and Load Share in Bay Extensions	
Step	Action
1	Turn all rectifiers to STBY.
2	Connect a resistive load box (proper voltage) to the system's positive and negative bus bars.
3	Verify that the system load is less than 50 amperes.
4	Increase the system load to 200 amperes.
5	Turn ON all the rectifiers; after approximately 60 seconds, verify that the load is divided equally among all the rectifiers (within 2 amperes).
6	Reduce the system load. Verify that the rectifiers continue to share the load.
7	Remove system load.

Replacement Parts

System

Table 11-A provides a list of replacement parts for GPS 4848/100.

Ordering Comcode	Description
Cabinet	
406204230	3 ampere alarm fuse
402328926	0.18 ampere alarm fuse
406530725	1-1/3 ampere alarm fuse
405673161	1/2 ampere panel alarm fuse (WP90247 L3)
406420273	GMT fuse puller tool
848262622	BLJ3 terminal board
408229318	Wire insertion tool
848703419	BIC9 bay interface card
107900169	EBV2 load disconnect board
107604076	BJN1 battery disconnect board
407226786	Lens cover, red
407227172	Cabinet alarm lamp, 48V
Rectifier and Rectifier Shelf	
108972238	595LTA, 220 ampere rectifier
108990405	595LTB, 220 ampere rectifier
848693586	Fan (2 Required)
901181834	Insulated Allen-head wrench
Distribution	
405673161	1/2 ampere alarm fuse
Galaxy Millennium Controller	
406677880	Battery TL5101 for BSJ
406530725	1-1/3 ampere fuse (GMT)
406204230	3 ampere fuse (GMT)

Table 11-A: GPS 4848/100 Replacement Parts

Millennium Controller Circuit Boards

Table 11-B lists the spare parts of the Galaxy Millennium Controller.

Ordering Comcode	Description
108029679	Display board (BSK1)
108029687	Alarm wire wrap board (BSL1)
848194551	Insulation displacement alarm board (BSL2)
108029653	Basic control board (BSH1)
847950912	LCD module assembly display board
108029661	Intelligent control board (BSJ1)
108851338	Modem board (BSM5)
108163601	Data switch board (BSW1)
108340100	Gateway board (EBW1)

Table 11-B Galaxy Millennium Controller Circuit Boards

Additional Ordering Information

Documentation

Table 11-C lists documentation associated with the GPS 4848/100.

DocumentNumber	Description
H569-434	GPS 4848/100 Ordering Guide
167-792-157	GPS Installation Guide
167-792-180	Galaxy Millennium Controller Product Manual
167-790-063	Remote Peripheral Monitoring System ProductManual
193-104-105	EasyView Software Product Manual
193-104-106	Galaxy Gateway Product Manual

Table 11-C Product Documentation

Software

EasyView software is a Windows-compatible communications package designed specifically for use with Galaxy controllers. Download EasyView software from omnionpower.com

Click “Downloads” and click on the appropriate EasyView download button.

12 Troubleshooting Preparations

Preliminary

Introduction

This section provides information needed in preparation for locating and interpreting visual indicators to help identify problems.

When replacing a part does not correct the problem or visual indicators do not identify a defective part, notify OmniOn Power Technical Support.

Safety

Review all safety instructions and warnings in the Safety section of the GPS Installation Guide before troubleshooting the GPS 4848/100.

Warning

Hazardous ac and dc voltages and/or energy are present. Caution should be exercised. Tools must be insulated to help prevent accidental contact with live surfaces.

Coordinate all troubleshooting activities with other personnel that may be working on the system.

Tools

The following tools are necessary in order to troubleshoot the GPS 4848/100:

- 3/16-inch (5 mm) Allen-head wrench
- Insulated hand tools
- Calibrated digital voltmeter (DVM) (0.05% accuracy on dc scale)
- ESD wrist strap

Troubleshooting Procedure

Purpose

The troubleshooting procedure described below is used when a trouble condition has been identified and a technician has been dispatched to the system location as a first and fundamental step in diagnosing and correcting the problem.

For all trouble conditions, proceed as follows:

Troubleshooting Procedure (continued)

Cabinet Alarm

1. Locate the system controller. The controller is typically located in the cabinet identified as BAY ONE. Because a trouble condition exists, the red alarm on the top of the cabinet will be illuminated. See Figure 12-1).

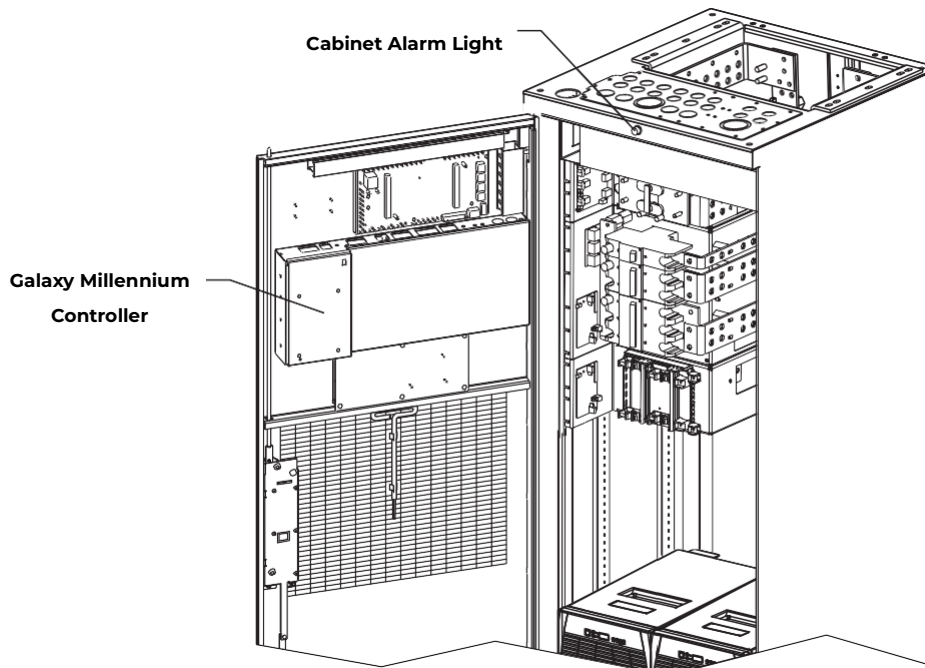

Figure 12-1: Location of Cabinet Alarm Light and Controller

System Status

1. Determine the system status. For most problems, one or more alarm and status LEDs will be illuminated. The controller default screen indicates system voltage and current, the system mode (i.e., FLOAT or EQUALIZE), and the number of alarms and/or warnings present.

If the screen is blank, but alarm and status LEDs are illuminated, call technical support.

If the entire panel is blank, check the F3 basic power fuse (Figure 12-3). Verify that the controller is getting power. If not, replace fuse. If the display is still blank, call technical support.

Alarms Menu

3. If the default screen appears normal, press the MENU button. The main menu appears with “Alarms” blinking. Press ENTER to obtain the Alarms menu. Additional data appears that will help to identify the problem.

Troubleshooting Procedure (continued)

Troubleshooting Tables

4. Based on the information presented by the alarm LEDs, select the appropriate table from the list below:

Section 13, Troubleshooting Millennium Systems	
Alarm LED	Table
AC	13-A, AC Alarms
BATT	13-B, Battery Alarms
BD	13-F, Miscellaneous Alarms
CTRL	13-C, Controller Alarms
DIST	13-D, Distribution Alarms
RECT	13-E, Rectifier Related Alarms
No LED*	13-F, Miscellaneous Alarms

*If an alarm condition exists, but no alarm LED is lit, refer to Table 13-F.

Identifying Problems

5. Once the appropriate table is identified, use the status LEDs and the alarm menu data to identify the specific problem that is causing the alarm.

Reference Figures

Figure Numbers and Titles

The following figures are provided for reference while performing the troubleshooting procedure:

Figure No.	Title
12-1	Location of Cabinet Alarm Light and Controller
12-2	Millennium Controller Display
12-3	Millennium Controller Fuses and Circuit Boards
12-4	Rectifier Display
12-5	Low Voltage Battery Disconnect Contactor Control Switches
12-6	AC Input Panel and Rectifier Connection
12-8	DC Distribution Panel
12-9	Low Voltage Load Disconnect Contactor Control Switches

Millennium Controller

Basic Controller

BSH (microprocessor board): After power up, or after a reset, the green and yellow LEDs will both be lit while self diagnostics are in progress (which will take about 10 seconds). If all diagnostics pass, the yellow LED will extinguish and the green LED will remain lit. If a failure is detected during diagnostics, the green LED will extinguish and the yellow LED will remain lit.

If a failure occurs during normal operation, the green LED will extinguish and the yellow LED will light.

Reference Figures (continued)

Millennium Controller (continued)

Intelligent Controller

BSJ (microprocessor board): After power up, or after a reset, the green and yellow LEDs will both be lit while self diagnostics are in progress (which will take about 30 seconds). If all diagnostics pass, the yellow LED will extinguish and the green LED will remain lit. If a failure is detected during diagnostics, the green LED will extinguish and the yellow LED will remain lit. If a terminal is attached to the local port during diagnostics, the diagnostic messages will show which test failed.

If a failure occurs during normal operation, the green LED will extinguish and the yellow LED will light.

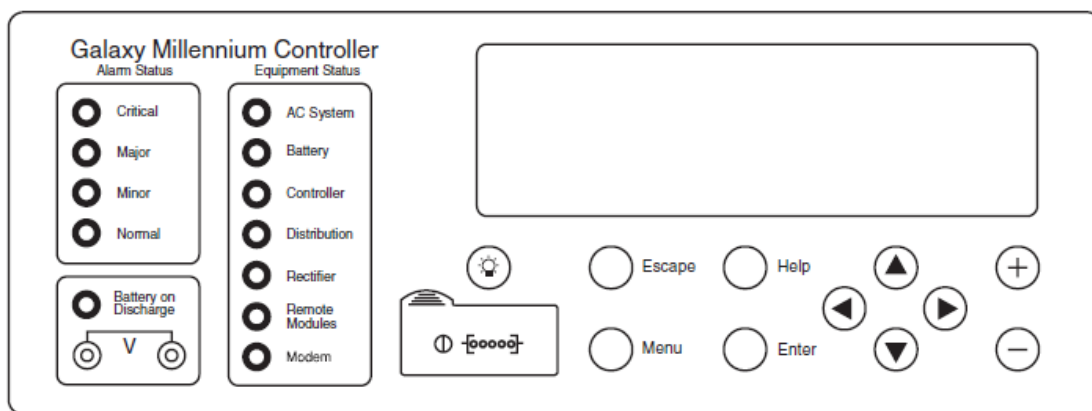

Figure 12-2: Millennium Controller Display

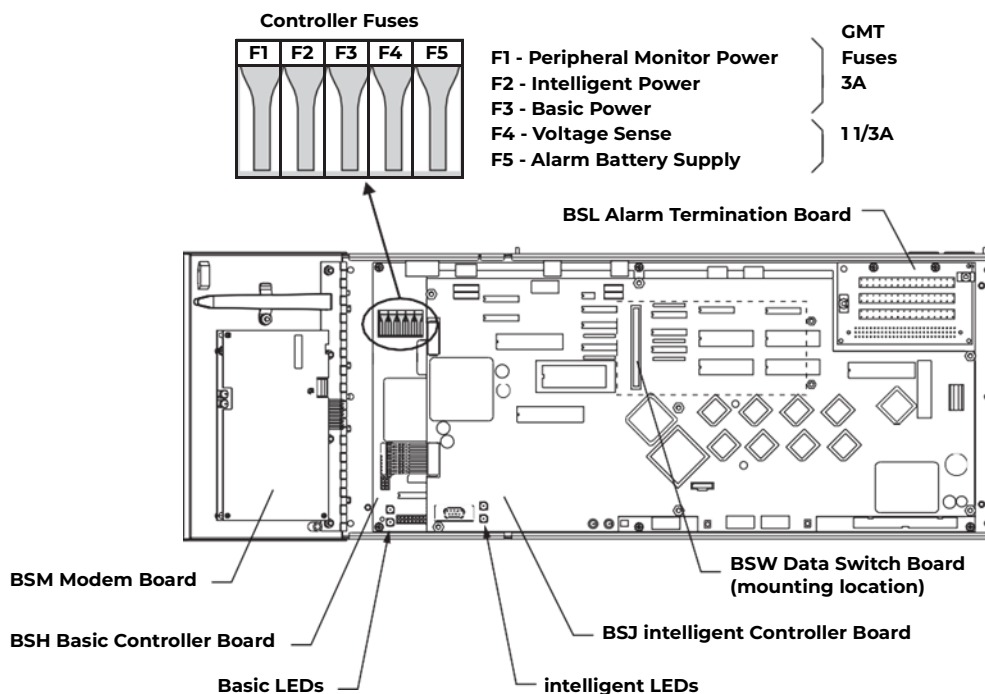

Figure 12-3: Millennium Controller Fuses and Circuit Boards

Reference Figures (continued)

Rectifier

During normal operation, the rectifier's green ON LED will be lit and the display will show the rectifier's output current.

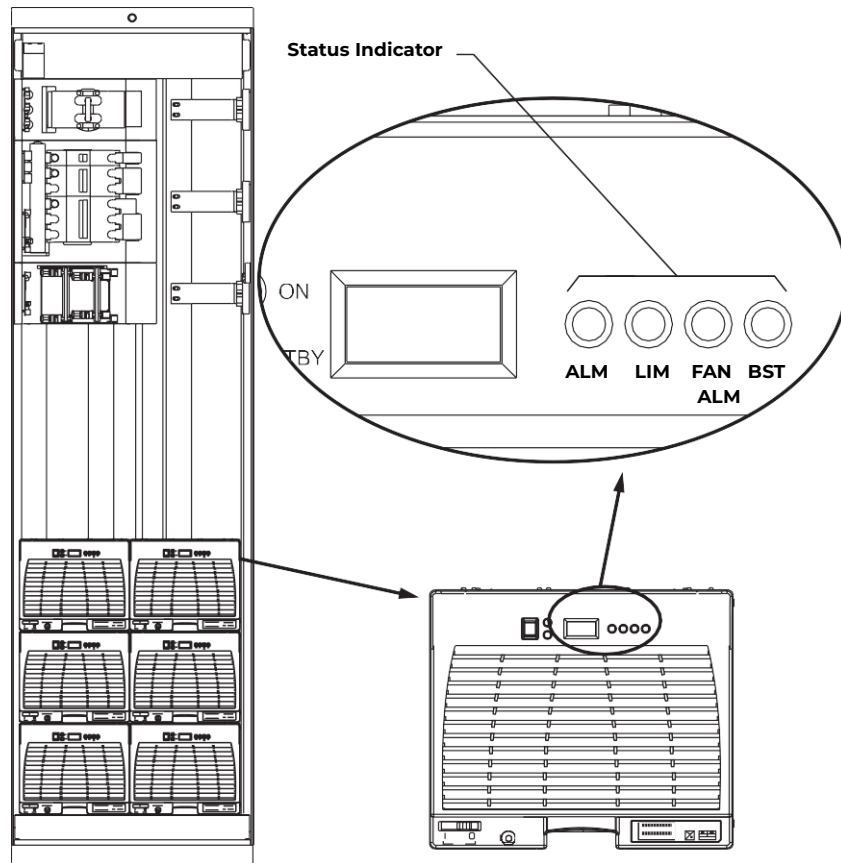
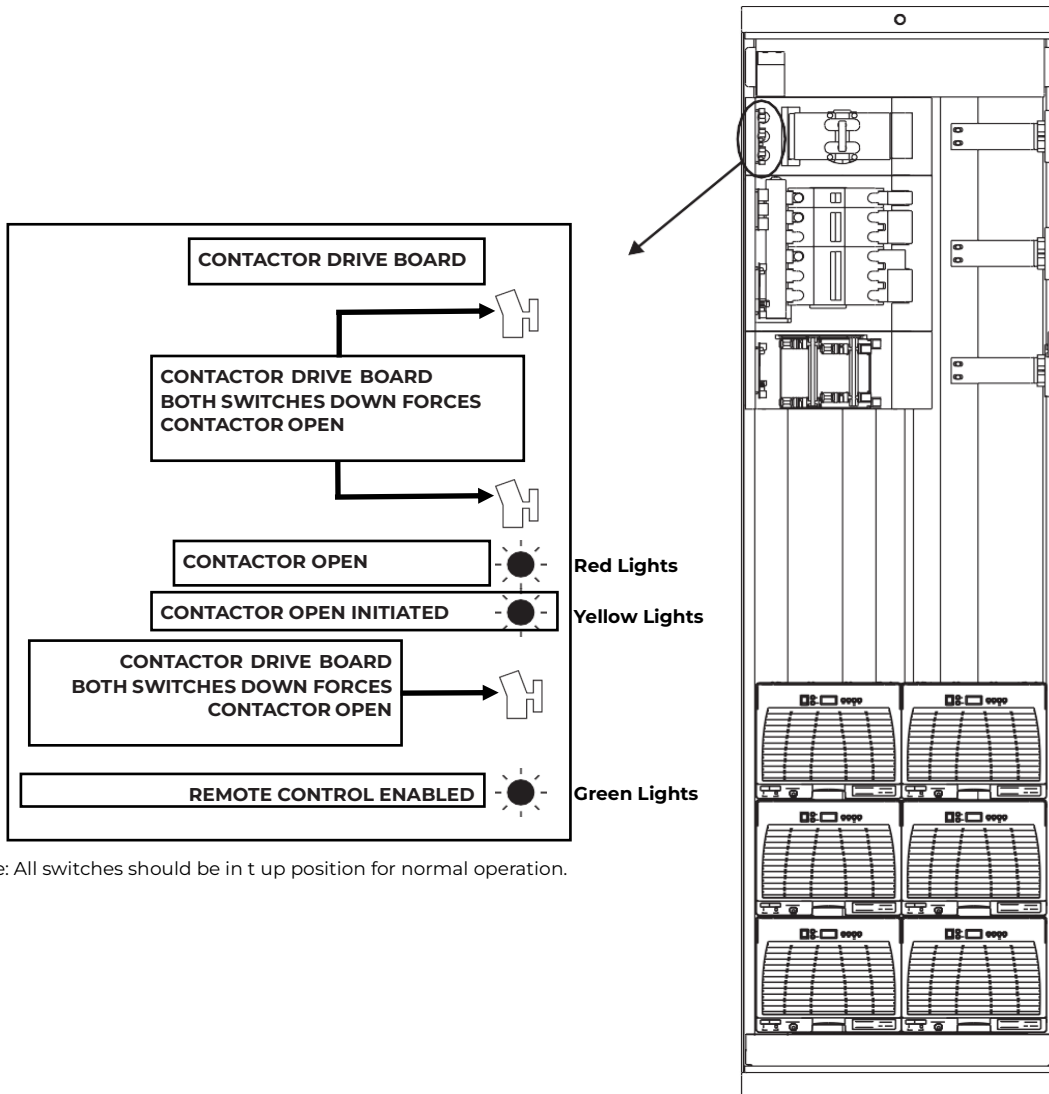

Figure 12-4: Rectifier Display

Reference Figures (continued)

Low Voltage Battery Disconnect

The low voltage battery disconnect (LVBD) feature consists of a contactor, circuitry on the BJB board, and associated wiring. Control of the contactor is dictated by the BJB contactor control board and the controller.



Note: All switches should be in the up position for normal operation.

Figure 12-5: Low Voltage Battery Disconnect Contactor Control Switches

Reference Figures (continued)

AC Input

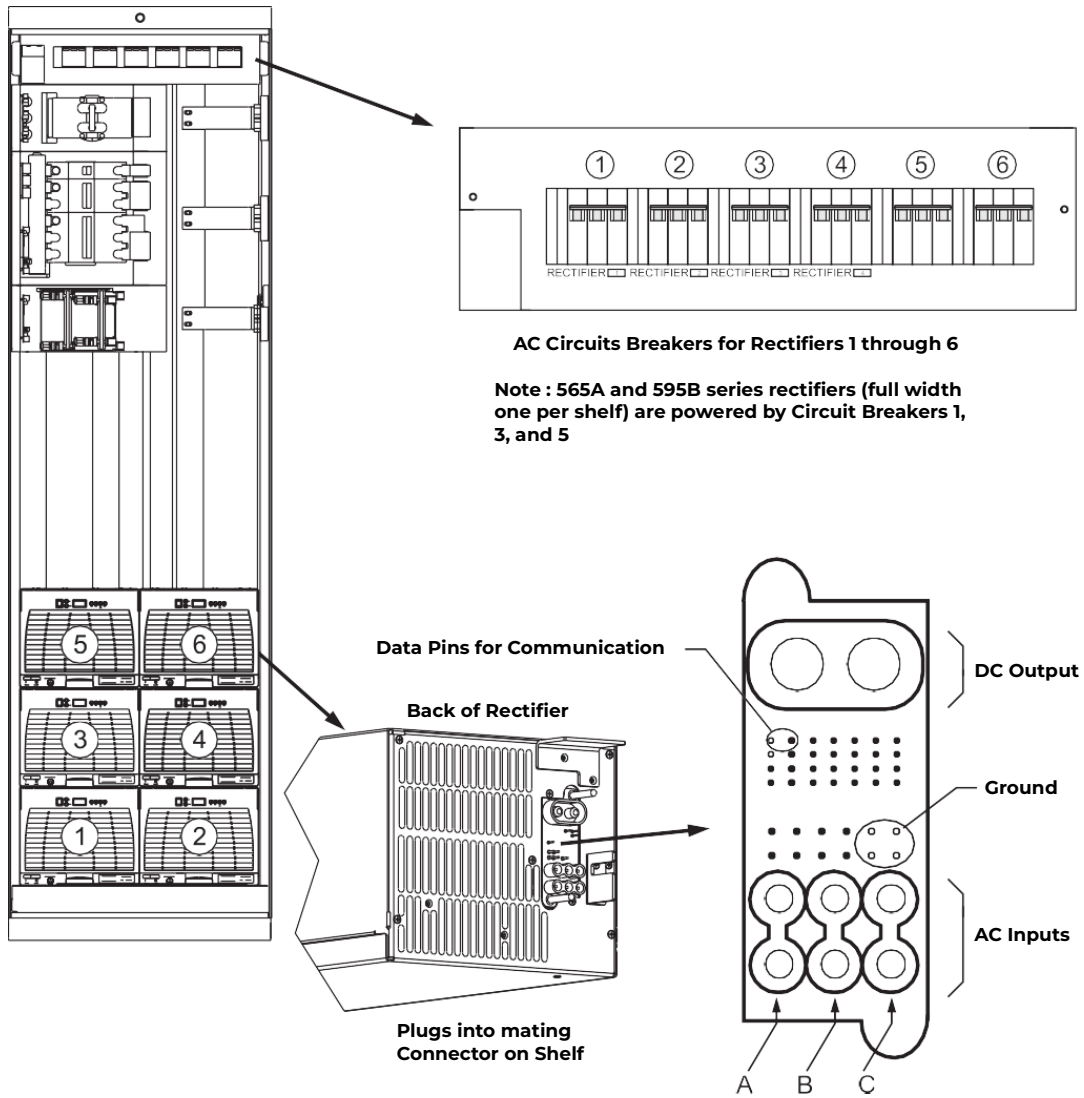

Rectifier	Phase Voltage Range
595A/595LTA	320Vac-530Vac
595B/595LTB	176Vac-254Vac

AC Inputs	Measure between :
Phase 1	A and B
Phase 2	B and C
Phase 3	C and A

Figure 12-6: AC Input Panel and Rectifier Positions, 6 Rectifiers

Reference Figures (continued)

AC Input

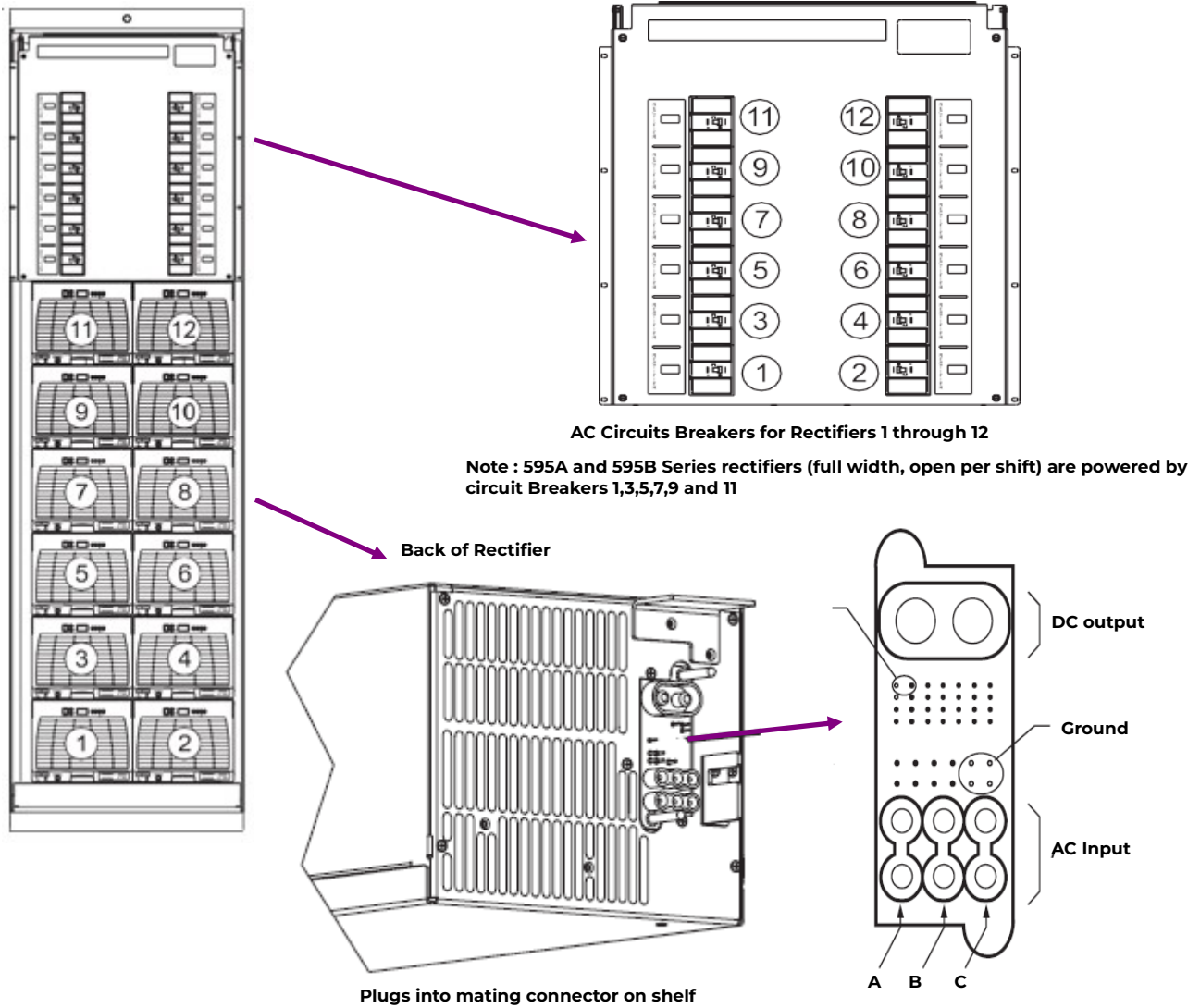

Rectifier	Phase Voltage Range
595A/595LTA	320Vac - 530Vac
595B/595LTB	176Vac - 254Vac

AC Inputs	Measure between :
Phase 1	A and B
Phase 2	B and C
Phase 3	C and A

Figure 12-7: AC Input Panel and Rectifier Positions, 12 Rectifiers

Reference Figures (continued)

DC Distribution

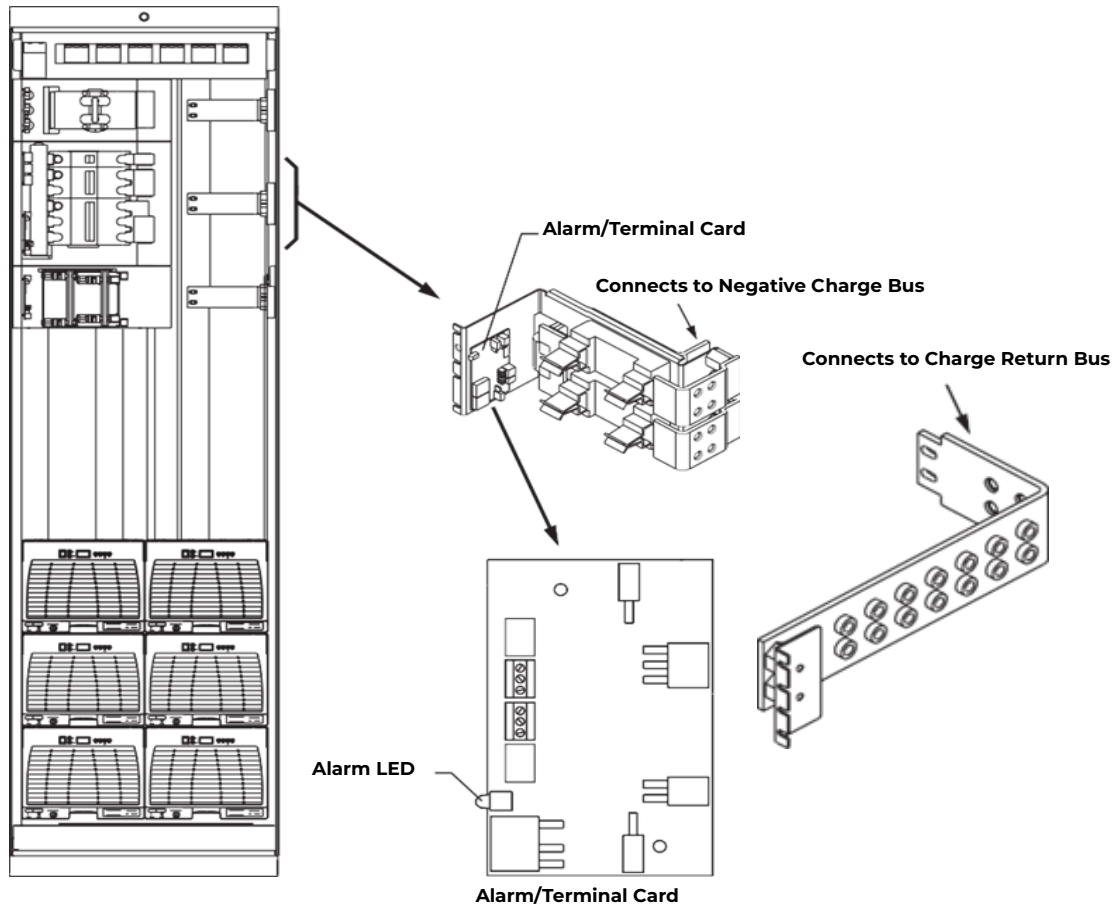

Figure 12-8: DC Distribution Panel

Reference Figures (continued)

Low Voltage Load Disconnect

The EBV low voltage load disconnect (LVLD) contactor control board is mounted on the right side of the cabinet, as shown in Figure 12-9.

The manual contactor control switch (SW300) is not meant to be used to permanently override the LVLD function. It is only to be used temporarily while servicing or testing the equipment.

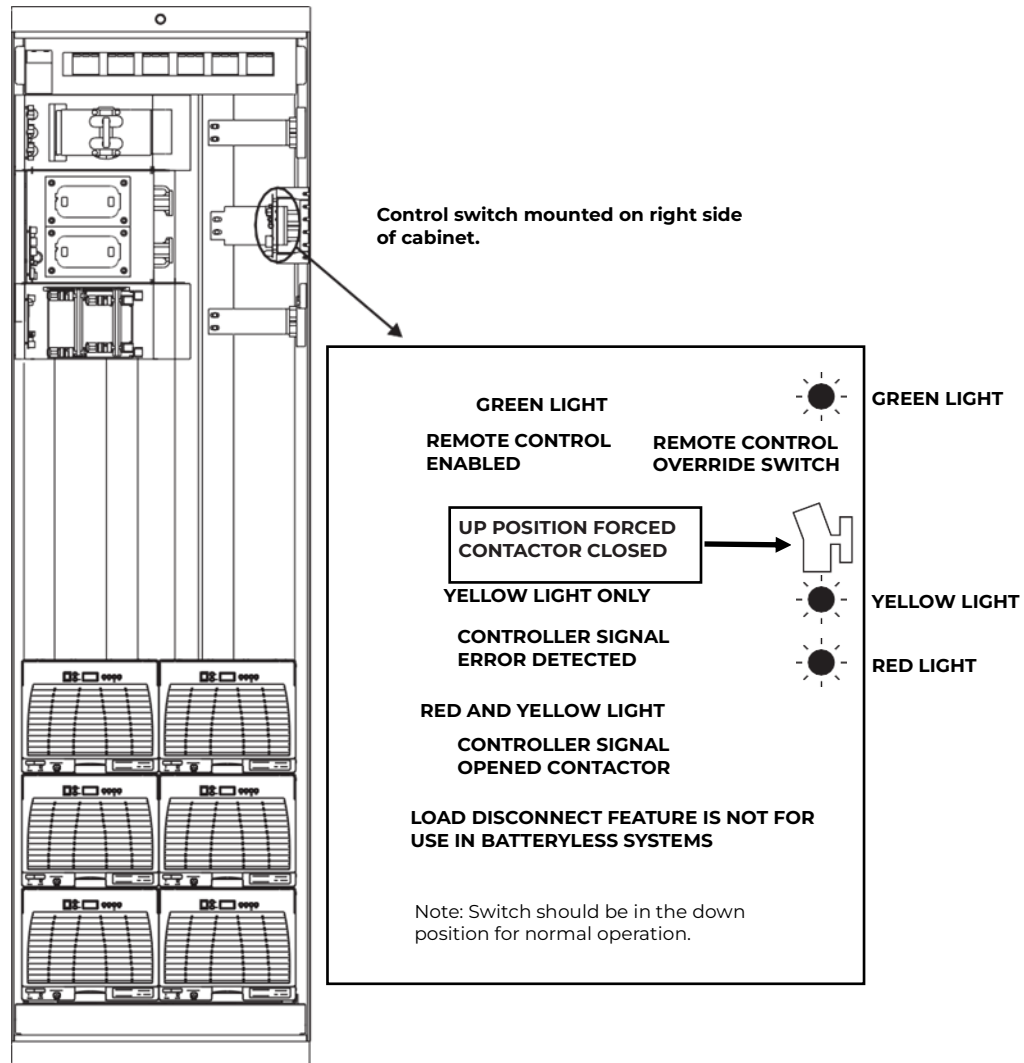

Figure 12-9: Low Voltage Load Disconnect Contactor Control Switches

13 Troubleshooting Millennium Systems

Introduction

In This Section

This section provides information for locating and interpreting visual indicators to help identify problems.

Preparation

Read Section 12, Troubleshooting Preparations, thoroughly before proceeding.

Technical Assistance

When visual indicators do not identify a defective part, notify OmniOn Power Technical Support.

Troubleshooting Tables

Organization

The tables in this section are organized alphabetically by Alarm LED, then grouped according to the status of the alarm: Critical (CRIT), Major (MAJ), or Minor (MIN).

Table Reference

Use the reference below to locate the Alarm LED and corresponding table.

Controller Alarm LED	Table
AC	13-A, AC Alarms
BATT	13-B, Battery Alarms
BD	13-F, Miscellaneous Alarms
CTRL	13-C, Controller Alarms
DIST	13-D, Distribution Alarms
RECT	13-E, Rectifier Related Alarms
RM	13-F, Miscellaneous Alarms
No LED*	13-F, Miscellaneous Alarms

*If an alarm condition exists, but no alarm LED is lit, refer to Table 13-F.

Rectifier Display Messages and LEDs

State	Display Message	LED Illuminated
Normal	Current	On
Output Limited	Current	LIM
Manual Standby	Blank	STBY
Remote Standby (Shutdown)	tr	STBY
Output Breaker Open	CB	ALM
Interlock Open	ILC	ALM
AC Fail	ACF	None
Phase Fail	PF	None
Over Temperature Shutdown	tA	ALM
Output Under Voltage Shutdown	LO	ALM
High Voltage Shutdown	HO	ALM
Internal Failure	LS, ICS, IP5, IP6, IP7, SEN, FSE, InF	ALM

13 Troubleshooting Millennium Systems (continued)

Millennium Controller Display

The Millennium display is illustrated below.

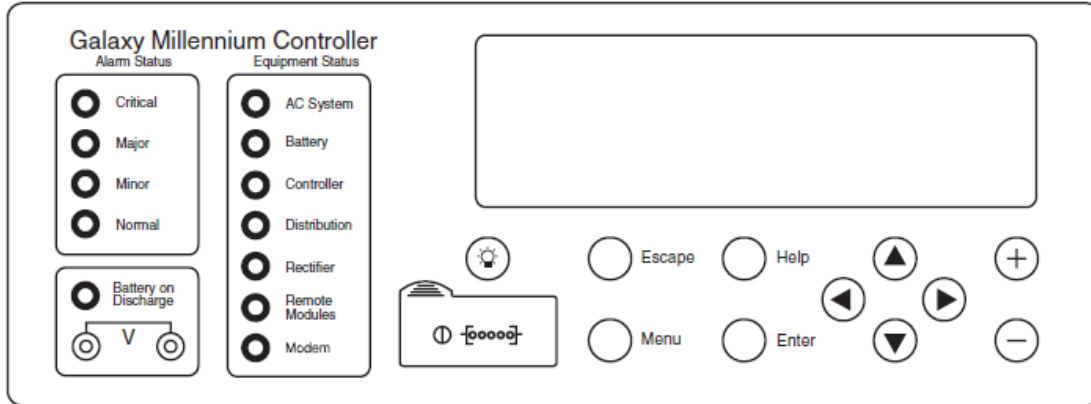

AC Alarm LED

Controller LED	Controller Alarm Status	Millennium Controller Display	Other Indication(s)	Possible Problem(s)	Possible Solution(s)
AC	MIN	AC Fail	ACF onrectifier display	Rectifier is not receiving ac power: <ul style="list-style-type: none"> AC input circuitbreaker has operated. AC input voltage is out of range. Internal rectifier failure 	<ul style="list-style-type: none"> Verify that ac circuit breaker is closed; close circuit breaker if operated. If the problem is not corrected, replace the rectifier.
AC	MIN	Engine Transfer Timeout	Engine may have alarm.	Remote engine or connection to engine has failed.	Call technical support.
AC	MIN	Phase Alarm	PF on rectifier display	Phase failure: <ul style="list-style-type: none"> Rectifier high voltage shutdown External phase imbalance or failure Internal rectifier failure 	<ol style="list-style-type: none"> Toggle the ON/STBY switch into the STBY position and then back into the ON position. If the problem is not corrected, replace the rectifier.

Table 13-A: AC Alarms

(See Figure 12-6)

13 Troubleshooting Millennium Systems (continued)

BATT Alarm LED

Controller LED	Controller Alarm Status	Millennium Controller Display	Other Indication(s)	Possible Problem(s)	Possible Solution(s)
BATT	CRIT	Very Low Voltage	--	Occurs in an operating system following an extended commercial ac power outage, during which the batteries are providing power for the system and the system voltage is approaching the user-defined low limit.	<ol style="list-style-type: none"> If commercial ac power is present but the system voltage remains low, call technical support. Investigate other alarms that may be present (rectifier-related alarms and the AC Fail alarm may also occur during the fault condition).
BATT* *Alarm must be configured to turn on the BATT LED; not a factory default.	MAJ	Contactors 1 Open	Red LED on contactor drive board is lit.	Contactor is open: <ul style="list-style-type: none"> Open has been initiated by controller. Open has been initiated manually. 	<ul style="list-style-type: none"> Follow instructions on the label adjacent to the contactor drive board (see Figure 12-5). If the problem is not corrected, call technical support.
BATT* *Alarm must be configured to turn on the BATT LED; not a factory	MAJ	Contactors 1 Fail	--	Contactors or drive board has failed.	Call technical support.
BATT	MIN	Open String	Alarm LED on battery fuse panel is lit.	Battery fuse has operated.	Replace the operated fuse.
BATT	MIN	Low Reserve Time	--	Controller has calculated that batteries are low.	Call technical support.

Table 13-B: Battery Alarms

(See Figure 12-5)

13 Troubleshooting Millennium Systems (continued)

CTRL Alarm LED

Controller LED	Controller Alarm Status	Millennium Controller Display Indication(s)	Other	Possible Problem(s)	Possible Solution(s)
CTRL	MAJ	Controller Fail	--	<ul style="list-style-type: none"> • BSH failure → • BSJ failure • Option board failure • Display failure • BIC failure 	<p>Check the BSH board to see if the green LED is extinguished and the yellow LED is lit. If so, perform the following steps:</p> <ol style="list-style-type: none"> 1. Press the SW200 reset switch on the top of the BSH board. If all diagnostics pass, it is possible that some type of "one time" abnormality occurred to cause the failure. 2. If the diagnostics did not pass, or if the problem recurs, unplug all the optional circuit board cables, then press the reset switch on the top of the BSH board again. If all the diagnostics pass, install optional circuit board cables one at a time, verifying operation after each. 3. If the diagnostics did not pass, replace the BSH board and verify the failure is resolved. If so, reinstall the optional circuit boards and cables one at a time. 4. If the problem is not corrected, call technical support.

Table 13-C: Controller Alarms
(See Figures 12-2 and 12-3)

13 Troubleshooting Millennium Systems (continued)

Controller LED	Controller Alarm Status	Millennium Controller Display	Other Indication(s)	Possible Problem(s)	Possible Solution(s)
CTRL	MAJ	Controller Fail	--	<ul style="list-style-type: none"> • BSH failure • BSJ failure → • Option board failure • Display failure • BIC failure 	<p>Check the BSJ board to see if the green LED is extinguished and the yellow LED is lit. If so, perform the following steps:</p> <ol style="list-style-type: none"> 1. Press the SW201 reset switch on the top of the BSJ board. (This circuit has an automatic restart, which will try three times to restart the microprocessor.) 2. If the diagnostics did not pass, or if the problem recurs, remove all the optional circuit board cables, then press the reset switch on the top of the BSJ board again. If all the diagnostics pass, install optional circuit board cables one at a time, verifying operation after each. 3. If the diagnostics did not pass, replace the BSJ board and verify the failure is resolved. If so, reinstall the optional circuit boards and cables one at a time. 4. If the problem is not corrected, call technical support.

Table 13-C: Controller Alarms (Continued)
(See Figures 12-2 and 12-3)

13 Troubleshooting Millennium Systems (continued)

Controller LED	Controller Alarm Status	Millennium Controller Display	Other Indication(s)	Possible Problem(s)	Possible Solution(s)
CTRL	MAJ	Controller Fail	--	<ul style="list-style-type: none"> • BSH failure • BSJ failure • Option board failure → • Display failure • BIC failure 	<p>Check the option boards (modem and data switch) to see if the green LED is extinguished and the yellow LED is lit. If so, perform the following steps:</p> <ol style="list-style-type: none"> 1. Press the SW201 reset switch on the top of the BSJ board. (This circuit has an automatic restart, which will try three times to restart the microprocessor.) If the BSJ is not present, press the reset switch on the top of the BSH board. 2. If the diagnostics did not pass, or if the problem recurs, replace the failed option board.
CTRL	MAJ	Controller Fail	--	<ul style="list-style-type: none"> • BSH failure • BSJ failure • Option board failure • Display failure → • BIC failure 	<p>If the front panel LCD module, LEDs, or switches fail, perform the following steps:</p> <ol style="list-style-type: none"> 1. Verify that the ribbon cable from the BSH board to the display is not cut, abraded, or otherwise mangled. Replace the cable if damaged. 2. Press SW200 to reset the BSH board. 3. If the LCD module is still not operating, replace the LCD module; if the switches and LEDs are still not operating, replace the BSH board.

Table 13-C: Controller Alarms (Continued)
(See Figures 12-2 and 12-3)

13 Troubleshooting Millennium Systems (continued)

Controller LED	Controller Alarm Status	Millennium Controller Display	Other Indication(s)	Possible Problem(s)	Possible Solution(s)
CTRL	MAJ	Controller Fail	--	<ul style="list-style-type: none"> BSH failure BSJ failure Option board failure Display failure BIC failure → 	<ol style="list-style-type: none"> Strap K1, K2, K3 on BLJ from "C" to "R" prior to replacing BIC. See Figure 8-2. Replace BIC.
CTRL	MAJ	Circuit Pack Fail	--	See "Controller Fail".	See "Controller Fail".
CTRL	MAJ	Controller Fuse	--	Fuse has operated.	Replace the controller fuse labeled F2 (intelligent power).
CTRL	MAJ	Alarm Battery Supply Fuse	--	Fuse has operated.	Replace the controller fuse labeled F5 (alarm battery supply).
CTRL	MAJ	Remote Peripheral Fuse	--	Fuse has operated.	Replace the controller fuse labeled F1 (option power).
CTRL	MAJ	Sense/Control Fuse	--	Fuse has operated.	Replace the controller fuse labeled F4 (voltage sense).
CTRL	MAJ	Bay Interface ID Conflict	--	Two or more bay interface cards (BICs) have the same ID number.	Following instructions printed on the label over the BIC, adjust the DIP switches to change the ID number.
CTRL	MAJ	Major Communication Fail Alarm	Blinking ALMED on rectifiers or red LED on BIC	Loss of communication with controller: <ul style="list-style-type: none"> Defective interface from BIC or multiple rectifiers to controller Internal failure of controller, BIC, or multiple rectifiers 	<ol style="list-style-type: none"> Verify that the controller is powered and operating correctly. If there are no controller alarms, replace the equipment that has lost communication. If the problem is not corrected, call technical support.

Table 13-C: Controller Alarms (Continued)
(See Figures 12-2 and 12-3)

Controller LED	Controller Alarm Status	Millennium Controller Display	Other Indication(s)	Possible Problem(s)	Possible Solution(s)
CTRL	MIN	Minor Communication Fail Alarm	Blinking ALM LED on rectifier	Loss of communication with controller: <ul style="list-style-type: none"> Defective interface from rectifier to controller Internal controller or rectifier failure 	<ol style="list-style-type: none"> Verify that the controller is powered and operating correctly. If there are no controller alarms, replace the equipment that has lost communication. If the problem is not corrected, call technical support.
CTRL	MIN	Self Fail Test	--	See "Controller Fail".	See "Controller Fail".
CTRL	MIN	Thermal Probe Failure	--	Battery thermal probe has failed.	Call technical support.

Table 13-C: Controller Alarms (Continued)
(See Figures 12-2 and 12-3)

13 Troubleshooting Millennium Systems (continued)

DIST Alarm LED

Controller LED	Controller Alarm Status	Millennium Controller Display	Other indication(s)	Possible Problem(s)	Possible Solution(s)
DIST	MAJ	External Fuse Major	Alarm LED on dc distribution panel is lit.	DC load fuse or circuit breaker has operated.	Replace fuse or reset circuit breaker.
DIST* *Alarm must be configured to turn on the DIST LED; not a factory default.	MAJ	Contactor 2 (or 3) Open	Red LED on contactor drive board is lit.	Contactor is open: <ul style="list-style-type: none"> Open has been initiated by controller. Open has been initiated Manually. 	<ol style="list-style-type: none"> Follow instructions on the label adjacent to the contactor drive board (see Figure 12-8). If the problem is not corrected, call technical support.
DIST* *Alarm must be configured to turn on the DIST LED; not a factory default.	MAJ	Contactor 2 (or 3) Fail	--	Contactor or drive board has failed.	Call technical support.

Table 13-D: Distribution Alarms
(See Figures 12-7 and 12-8)

RECT Alarm LED

Controller LED	Controller Alarm Status	Millennium Controller Display	Rectifier LED	Rectifier Display	Possible Problem(s)	Possible Solution(s)
RECT	MAJ	ID Not Configured	None	None	Rectifier ID number has not been set.	Set rectifier ID using procedure in Section 11, "Installing or Replacing a Rectifier."
RECT	MAJ	ID Conflict	None	None	Two or more rectifiers have the same ID number.	See above.
RECT	MAJ	Multiple Rectifier Fail	ALM	None	More than one rectifier has an ALM LED lit.	See alarms listed below.
RECT	MAJ	High Voltage Alarm	ALM	HO	<ul style="list-style-type: none"> Lightning has struck system. Internal rectifier failure 	<ol style="list-style-type: none"> Toggle the ON/ STBY switch into the STBY position and then back into the ON position. If the problem is not corrected, replace the
RECT	MIN	Rectifier Fail	ALM	HO	<ul style="list-style-type: none"> High output voltage: Rectifier high voltage shutdown Internal rectifier failure 	<ol style="list-style-type: none"> Verify the configurable HV thresholds in the controller. Toggle the ON/ STBY switch into the STBY position and then back into the ON position. If the problem is not corrected, replace the rectifier.

Table 13-E: Rectifier Related Alarms
(See Figures 12-4 and 12-6)

13 Troubleshooting Millennium Systems (continued)

Controller LED	Controller Alarm	Millennium Controller Display	Rectifier LED	Rectifier Display	Possible Problem(s)	Possible Solution(s)
RECT	MIN	Rectifier Fail	ALM	TA	Thermal alarm: <ul style="list-style-type: none"> Excessive ambient temperature Internal rectifier failure 	<ol style="list-style-type: none"> Verify that there is no obstruction of the fan inlet. Toggle the ON/ STBY switch into the STBY position and then back into the ON position. If the problem is not corrected, replace the rectifier.
RECT	MIN	Rectifier Fail	ALM	CB	Circuit breaker alarm: <ul style="list-style-type: none"> DC output circuit breaker open Internal rectifier failure 	<ol style="list-style-type: none"> Toggle the ON/ STBY switch into the STBY position; toggle the DC output circuit breaker into the OFF position and then into the ON position. Return the ON/STBY switch to the ON position. If the problem is not corrected, replace the rectifier.

Table 13-E: Rectifier Related Alarms (Continued)
(See Figures 12-4 and 12-6)

13 Troubleshooting Millennium Systems (continued)

Controller LED	Controller Alarm Status	Millennium Controller Display	Rectifier LED	Rectifier Display	Possible Problem(s)	Possible Solution(s)
RECT	MIN	Rectifier Fail	ALM	ICS IP5 IP6 IP7 InF FSE LS	Internal rectifier failure	<ol style="list-style-type: none"> 1. Place the ac circuitbreaker for the rectifier in the OFF position. 2. Remove the rectifier from the shelf. 3. Wait for 30 seconds or until all front panel display LEDs have extinguished. 4. Replace the rectifier. 5. Return the ac breaker to the ON position. 6. Place the rectifier ON/STBY switch into the ON position. 7. If the problem is not corrected, replace the rectifier.
RECT	MIN	Rectifier Fail	ALM	LO	Low output Voltage: <ul style="list-style-type: none"> • Excessive output current • Internal rectifier failure 	<ol style="list-style-type: none"> 1. Toggle the ON/STBY switch into the STBY position and then back into the ON position. 2. If the problem is not corrected, replace the rectifier.

Table 13-E: Rectifier Related Alarms (Continued)
(See Figures 12-4 and 12-6)

13 Troubleshooting Millennium Systems (continued)

Controller LED	Controller Alarm Status	Millennium Controller Display	Rectifier LED	Rectifier Display	Possible Problem(s)	Possible Solution(s)
RECT	MIN	Rectifier Fail	ALM	SEN	Thermal sensor failure: <ul style="list-style-type: none"> Internal rectifier failure 	<ol style="list-style-type: none"> Place the ac circuit breaker for the rectifier in the OFF position. Remove the rectifier from the shelf. Wait for 30 seconds or until all front panel display LEDs have extinguished. Replace the rectifier. Return the ac breaker to the ON position. Place the rectifier ON/STBY switch into the ON position. If the problem is not corrected, replace the rectifier with a new one.
RECT	MIN	Rectifier Fail	FANALM	None	Fan failure	Replace the fan in the rectifier.
RECT	MIN	Manual Off	STBY	Blank	Rectifier has been manually turned off.	Turn rectifier on.
RECT	MIN	External Transfer Shutdown	STBY	TR	System is operating on external engine.	No action required.
RECT	MIN	High Float Voltage	None	None	Configuration problem	Call technical support.
RECT	MIN	Excess Rectifier Drain	None	None	Internal rectifier fault	Replace rectifier.

Table 13-E: Rectifier Related Alarms (Continued)

(See Figures 12-4 and 12-6)

13 Troubleshooting Millennium Systems (continued)

Controller LED	Controller Alarm Status	Millennium Controller Display	Rectifier LED	Rectifier Display	Possible Problem(s)	Possible Solution(s)
RECT	MIN	Excess System Drain	None	None	System load exceeds shunt rating.	Call technical support.
RECT	MIN	Limited Recharge	None	None	Rectifier capacity has been exceeded.	Install more rectifiers.
RECT	MIN	Rectifier Fail	ALM	ILC	Rectifier Notfully seated.	<ol style="list-style-type: none"> 1. Place the ac circuit breaker for the rectifier in the OFF position. 2. Remove the rectifier from the shelf. 3. Wait for 30 seconds or until all front panel display LED shave extinguished. 4. Replace the rectifier. 5. Return the ac breaker to the ON position. 6. Place the rectifier ON/STBY switch into the ON position. 7. If the problem is not corrected, replace the rectifier with a new one.

Table 13-E: Rectifier Related Alarms (Continued)
(See Figures 12-4 and 12-6)

13 Troubleshooting Millennium Systems (continued)

BD and RM Alarm LEDs, or No LED

Controller LED	Controller Alarm Status	Millennium Controller Display	Other Indication(s)	Possible Problem(s)	Possible Solution(s)
BD	MAJ	Battery on Discharge	Rectifiers may say ACF.	Temporary condition that may be associated with other alarms	Call technical support.
RM	MIN	Module Failure	Green LED on RPM will not blink.	Remote Peripheral Module has failed.	Call technical support.
RM	MIN	Measurement Out of Range	--	<ul style="list-style-type: none"> Data being sensed exceeds remote peripheral module's capability. Remote peripheral module has failed. 	Call technical support.
None	MAJ	Auxiliary Major	Auxiliary equipment may have alarm.	Problem with operation of auxiliary equipment	Call technical support.
None	MIN	Auxiliary Minor	Auxiliary equipment may have alarm.	Problem with operation of auxiliary equipment	Call technical support.
None	None	None	<ul style="list-style-type: none"> STBY LED on rectifier is lit. TR on rectifier display 	Remote transfer: <ul style="list-style-type: none"> Rectifier is in STBY. 	Remove the remote standby command issued by the controller.
None	None	None	Red LED is lit on some battery contactor drive boards, while green LED is lit on	If a green LED is lit despite a contactor open command issued by the controller, the drive card or the contactor has failed.	Call technical support.

Table 13-F: Miscellaneous Alarms

14 Product Warranty

A. Seller warrants to Customer only, that:

1. As of the date title to Products passes, Seller will have the right to sell, transfer, and assign such Products and the title conveyed by Seller shall be good;
2. During the warranty period stated in Sub-Article B below, Seller's Manufactured Products (products manufactured by Seller), which have been paid for by Customer, will conform to industry standards and Seller's specifications and shall be free from material defects;
3. With respect to Vendor items (items not manufactured by Seller), Seller warrants that such Vendor items, which have been paid for by Customer, will be free from material defects for a period of sixty (60) days commencing from the date of shipment from Seller's facility.

B. The Warranty Period listed below is applicable to Seller's Manufactured Products furnished pursuant to this Agreement, commencing from date of shipment from Seller's facility, unless otherwise agreed to in writing:

Warranty Period

Product Type	New Product	Repaired Product*
Central Office Power Equipment	24 Months	6 Months

*The Warranty Period for a repaired Product or part thereof is six (6) months or, the remainder of the unexpired term of the new Product Warranty Period, whichever is longer.

- C. If, under normal and proper use during the applicable Warranty Period, a defect or nonconformity is identified in a Product and Customer notifies Seller in writing of such defect or nonconformity promptly after Customer discovers such defect or nonconformity, and follows Seller's instructions regarding return of defective or nonconforming Products, Seller shall, at its option attempt first to repair or replace such Product without charge at its facility or, if not feasible, provide a refund or credit based on the original purchase price and installation charges if installed by Seller. Where Seller has elected to repair a Seller's Manufactured Product (other than Cable and Wire Products) which has been installed by Seller and Seller ascertains that the Product is not readily returnable for repair, Seller will repair the Product at Customer's site. With respect to Cable and Wire Products manufactured by Seller which Seller elects to repair but which are not readily returnable for repair, whether or not installed by Seller, Seller at its option, may repair the cable and Wire Products at Customer's site.
- D. If Seller has elected to repair or replace a defective Product, Customer shall have the option of removing and reinstalling or having Seller remove and reinstall the defective or nonconforming Product. The cost of the removal and the reinstallation shall be borne by Customer. With respect to Cable and Wire Products, Customer has the further responsibility, at its expense, to make the Cable and Wire Products accessible for repair or replacement and to restore the site. Products returned for repair or replacement will be accepted by Seller only in accordance with its instructions and procedures for such returns. The transportation expense associated with returning such Product to Seller shall be borne by Customer. Seller shall pay the cost of transportation of the repaired or replacing Product to the destination designated by Customer.
- E. Except for batteries, the defective or nonconforming Products or parts which are replaced shall become Seller's property. Customer shall be solely responsible for the disposition of any batteries.
- F. If Seller determines that a Product for which warranty service is claimed is not defective or nonconforming, Customer shall pay Seller all costs of handling, inspecting, testing, and transportation and, if applicable, traveling and related expenses.

- G. Seller makes no warranty with respect to defective conditions or nonconformities resulting from actions of anyone other than Seller or its subcontractors, caused by any of the following: modifications, misuse, neglect, accident, or abuse; improper wiring, repairing, splicing, alteration, installation, storage, or maintenance; use in a manner not in accordance with Seller's or Vendor's specifications or operating instructions, or failure of Customer to apply previously applicable Seller modifications and corrections. In addition, Seller makes no warranty with respect to Products which have had their serial numbers or month and year of manufacture removed, altered, or experimental products or prototypes or with respect to expendable items, including, without limitation, fuses, light bulbs, motor brushes, and the like. Seller's warranty does not extend to any system into which the Product is incorporated. This warranty applies to Customer only and may not be assigned or extended by Customer to any of its customers or other users of the Product.

THE FOREGOING WARRANTIES ARE EXCLUSIVE AND ARE IN LIEU OF ALL OTHER EXPRESS AND IMPLIED WARRANTIES, INCLUDING BUT NOT LIMITED TO WARRANTIES OF MERCHANTABILITY AND FITNESS FOR A PARTICULAR PURPOSE. CUSTOMER'S SOLE AND EXCLUSIVE REMEDY SHALL BE SELLER'S OBLIGATION TO REPAIR, REPLACE, CREDIT, OR REFUND AS SET FORTH ABOVE IN THIS WARRANTY.

OmniOn Power Inc.

601 Shiloh Rd.
Plano, TX USA

omnionpower.com

We reserve the right to make technical changes or modify the contents of this document without prior notice. OmniOn Power does not accept any responsibility for errors or lack of information in this document and makes no warranty with respect to and assumes no liability as a result of any use of information in this document.

We reserve all rights in this document and in the subject matter and illustrations contained therein.

Any reproduction, disclosure to third parties or utilization of its contents – in whole or in parts – is forbidden without prior written consent of OmniOn Power. This document does not convey license to any patent or any intellectual property right.

Copyright© 2023 OmniOn Power Inc. All rights reserved.