

PRODUCT MANUAL

GPS4827 Infinity Power System

User's Guide

Product Manual

Ordering Code 850022019

Notice:

The information, specifications, and procedures in this manual are subject to change without notice. OmniOn Power assumes no responsibility for any errors that may appear in this document.

PRODUCT MANUAL

GPS4827 Infinity Power System

User's Guide

Table of Contents

1. Introduction	5
GPS4827	5
Customer Service Contacts	6
2. System Description	7
Overview	7
Architecture	9
3. Galaxy Millennium II Controller	13
4. Rectifiers	17
NE050AC48ATEZ	17
5. AC Input Panels	21
Overview	21
6. Battery Connection Panels	23
7. DC Distribution Panels	25
Function	25
8. External Return Bars	31
Overview	31
9. Millennium II Controller Operation	35
Controller Connections	37
Installing Circuit Packs	38
Thermal Probes	42
USB Interface	43
Local Port	43
Wiring Alarm Outputs	43
Wiring Alarm and Control Inputs	46
Fuses	50
Front Panel Display	51
Controller Defaults	54
Controller Display Menu Maps	61
10. Acceptance Testing	71
Introduction	71
Tools and Test Equipment	71
Test Precautions	71
Test Sequences	72

11. Circuit Boards 81
 Overview81

12. Specifications.....83
 Rectifier85

13. Safety.....87
 Safety Statements.....87

14. Maintenance and Replacement89
 Requirements89
 Rectifier Installation and Replacement Procedures89

15. Troubleshooting Procedure..... 91
 Preliminary91
 Troubleshooting Procedure.....92

16. Product Warranty.....93

17. Revision95

1. Introduction

GPS4827

OmniOn Power developed the Galaxy Power System GPS 4827 to support -48 volt telecommunications powering solutions in worldwide markets. The GPS 4827 combines 50-ampere, fan-cooled, switchmode rectifiers, microprocessor control technologies, battery and load disconnect/reconnect options, and a comprehensive line of fuse and circuit breaker dc distribution options in a modular front-access design. This modularity ensures easy access, simplified installation and maintenance, and allows the system to expand in capacity as power needs grow.

With 1,800-ampere maximum capacity, distribution flexibility, and universal ac input capability, the GPS 4827 supports switching, transmission, and wireless applications in central office locations and environmentally controlled remote sites (huts or vaults).

The main emphasis of this manual is to provide a general product description that will familiarize the user with the main components of the system and to provide guidelines for the basic maintenance of this Galaxy Power System.

The Millennium controller provides many advanced functions and features, including;

- Alarm Detection, Identification, and Reporting
- System and Component Status
- System and Feature Configuration
- System Alarm Thresholds
- Battery Management (Slope Thermal Compensation/Recharge Current Limit)
- Battery discharge testing
- Reserve Time Prediction
- Float/Boost Mode Control
- Low Voltage Disconnect Management
- Remote Access Control And Multiple Level Password Security
- History
- Statistics

Customer Service Contacts

Customer Service, Customer Training, Technical Support, Product Repair and Return, and Warranty Service

For customers in the United States, Canada, Puerto Rico, and the US Virgin Islands,

please dial 1-877-546-3243 (877 OmniOn) or for all other countries, please call 1-972-244-9288. This number is staffed from 7:00 am to 5:00 pm USA Central Time Zone (GMT -6), Monday through Friday, on normal business days. At other times, this number is still available, but for emergencies only. Services provided include initiating the spare parts procurement process, ordering documents, product warranty administration, and providing other product and service information.

For other customers worldwide the 800 number may be accessed after first dialing the Direct country code for the country where the call is originating, or you may contact your local field support center or your sales representative to discuss your specific needs.

On-Line Power Systems Product Manuals and Software

Power Systems product manuals and software are available on-line. Software includes Easy View and SNMP MIB.

2. System Description

Overview

Block Diagram

A basic block diagram of the Galaxy Power System 4827 is shown in Figure 2-1. It illustrates the arrangement and interconnection of the system components from the ac input to the dc output.

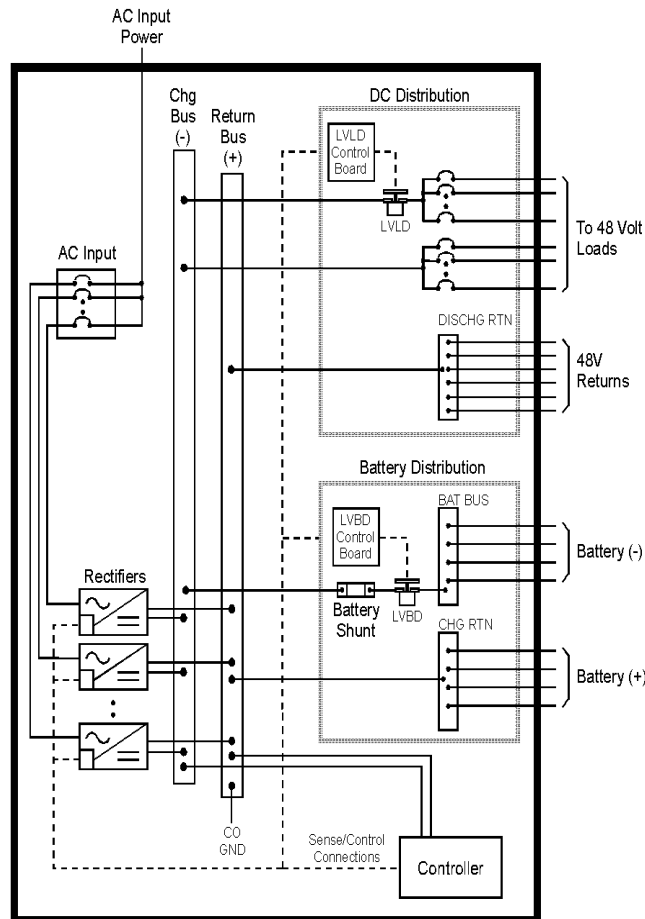

Figure 2-1 Block Diagram of the GPS4827

System Components

The power system accepts alternating current from the commercial utility or a standby ac power source and rectifies it to produce dc power for the using equipment. The system's control and alarm functions interact with the rectifiers and the office. In addition, the system provides overcurrent protection and charge, discharge, and distribution facilities. Battery reserve is connected in parallel and automatically provides a source of dc power if the commercial or standby ac fails. Battery reserve can be engineered to supply dc power for a specific period of time. In normal practice, battery capacity is sized to provide 3 to 8 hours of reserve time.

AC Input: connects the commercial and/or standby ac power sources to the rectifiers within the system and provides overcurrent protection. In some applications the ac service is wired directly to the rectifiers and overcurrent protection is provided at the service panel.

Rectifiers: convert an ac source voltage into the dc voltage level required to charge and float the batteries and to power the using equipment.

Controller: provides the local and remote control, monitoring, and diagnostic functions required to administer the power system.

Batteries: provide energy storage for an uninterrupted power feed to the using equipment during loss of ac input or rectifier failure.

DC Distribution Panel: provides overcurrent protection, connection points for the using equipment, and bus bars used to interconnect the rectifiers, batteries, and dc distribution.

Battery Connection Panel: provides connection points for the battery strings through battery disconnect fuses or contactors and current monitoring shunts.

Architecture

Configurations

The GPS 4827 is a 7-foot cabinet that can provide up to 1800 amps of DC power in single or multiple cabinets. Shown in Figures 2-2, 2-3 and 2-4.

Cabinets can contain ac distribution, dc distribution, a battery connection panel, rectifiers, and a system controller. Cabinets can also be ordered as rectifier only or distribution only cabinets.

Illustrations

Figure 2-3 shows how supplemental cabinets may be added to grow the system for more distribution. The rectifier output buses are interconnected to permit the cabinet to share current and ensure common voltage references for all system rectifiers. The total system ampacities must not exceed 1800A.

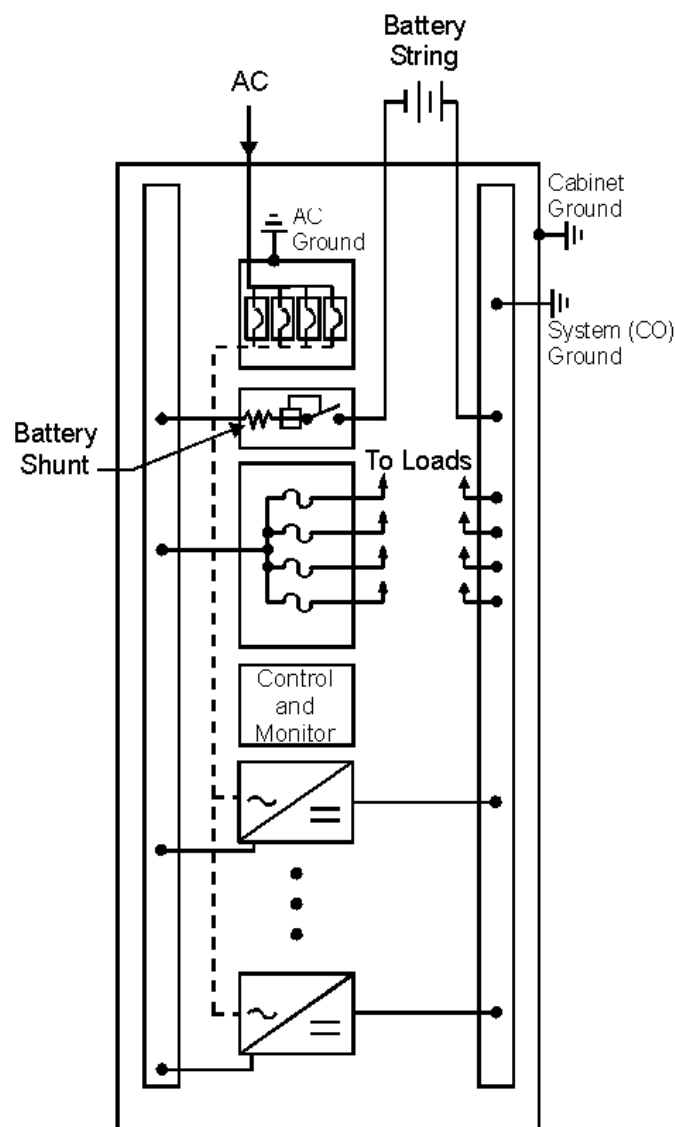

Figure 2-2 Cabinet schematic

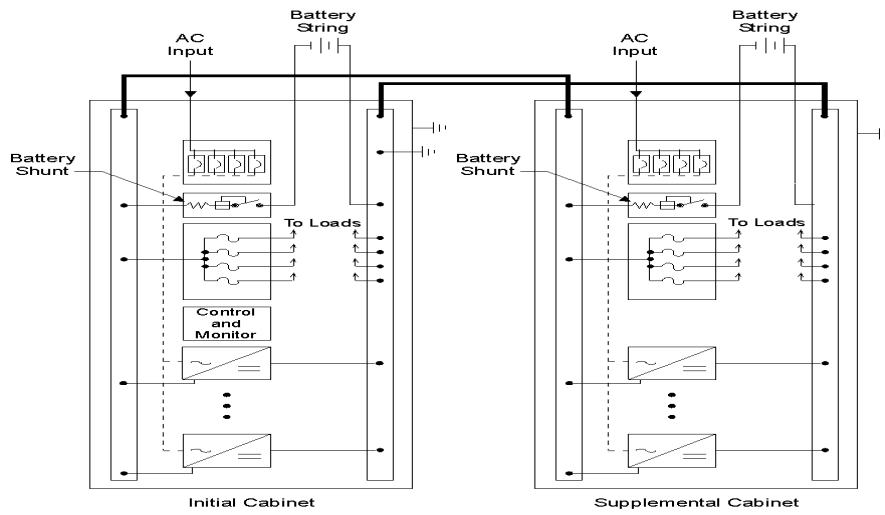

Figure 2-3 Schematic of Two-cabinet System Architecture 1800A Maximum per system.

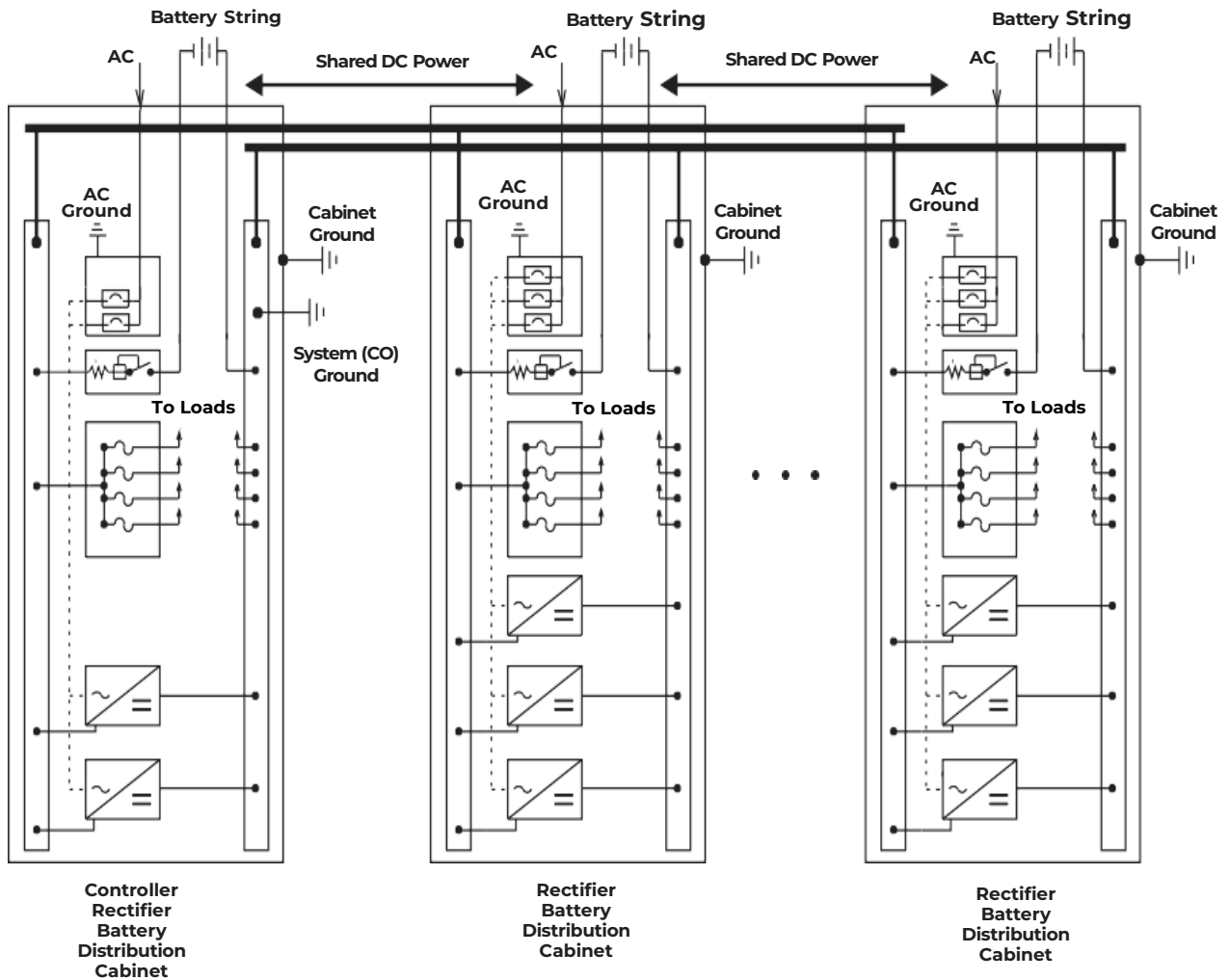

Figure 2-3 Schematic of Two-cabinet System Architecture 1800A Maximum per system.

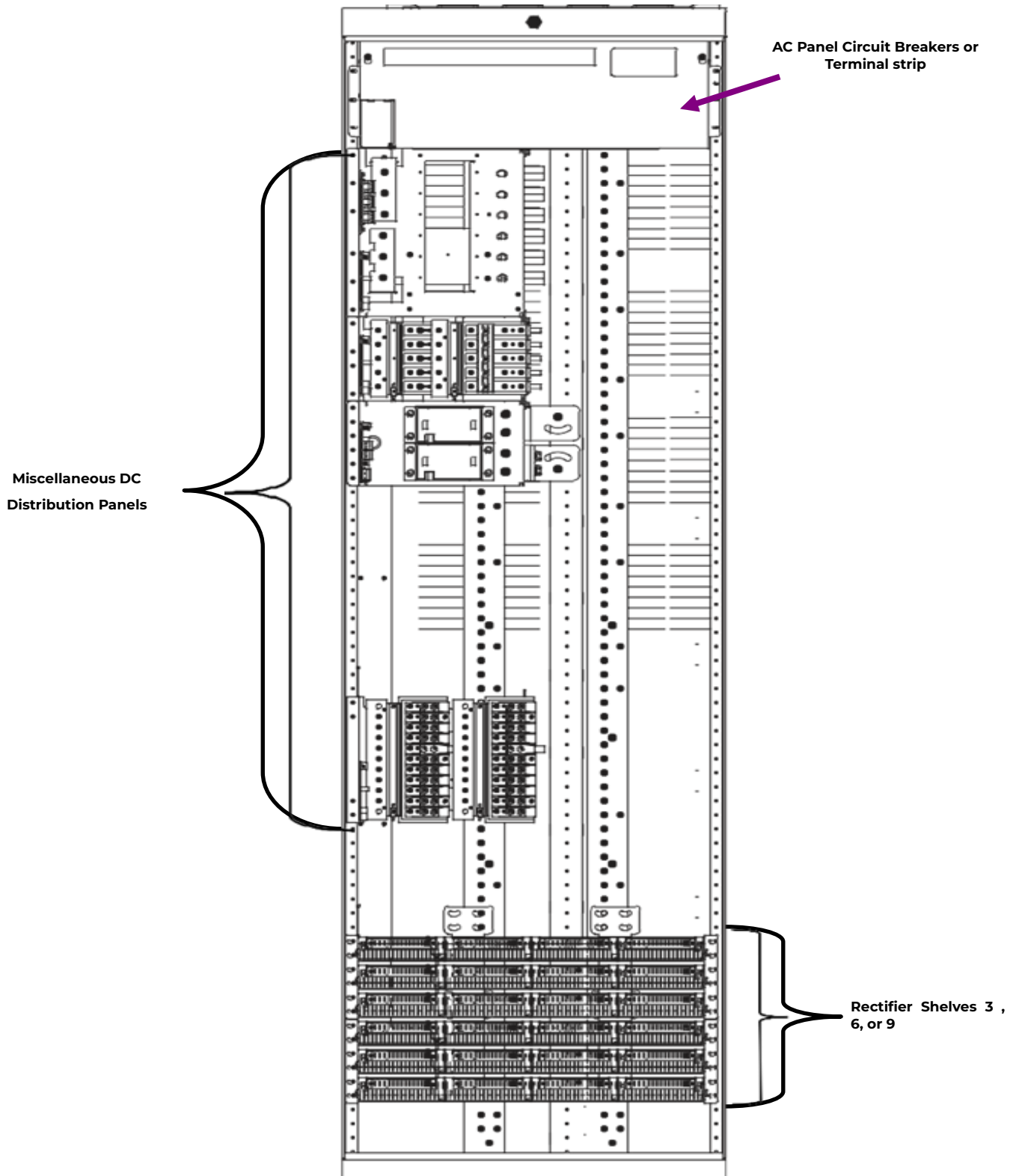

Figure 2-5 GPS4827 Six shelf cabinet with door removed

This page intentionally left blank

3. Galaxy Millennium II Controller

Overview

Introduction

The GPS 4827 comes equipped with the Galaxy Millennium II Controller. This section describes the controller operation and detailed information about the features of the front panel keys, LEDs, and display.

The Galaxy Millennium II Controller provides advanced local and remote monitoring and data acquisition features. The controller monitors system parameters; such as, system voltage and current, and components; such as rectifiers, and distribution circuits. The controller reports the status and issues appropriate alarms in the event a failure occurs.

Each cabinet is equipped with a bay interface card (BIC). The BIC acts as an interface to the cabinet control and alarm signals.

User Interface and Display

The Millennium II's primary user interface is a backlit LCD front panel display that can be viewed in English or Spanish, two rows of LEDs, an array of pushbutton keys, and a pair of test jacks.

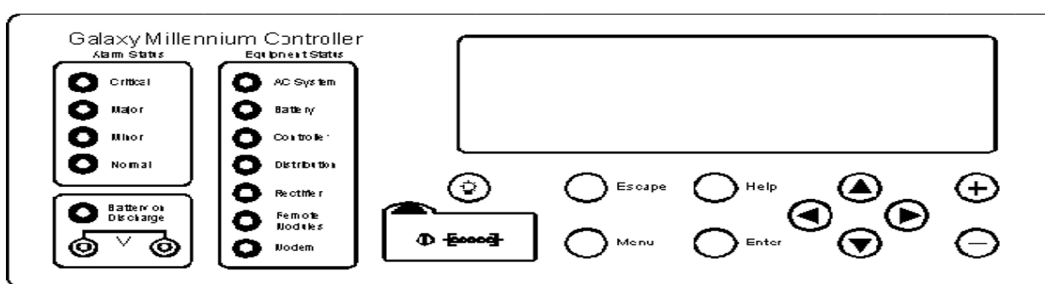

Figure 3-1 illustrates the front panel.

Default Display

The default display shows basic system status; system voltage, load current, and plant state. The controller returns to this display approximately three minutes after a key is pressed. The information on the screen is updated automatically approximately every two seconds.

The default screen displays the following: The first line shows the number of alarms and warnings present in the system, the date, and the time. The next two lines show the system voltage and the system load. The last line shows the system mode, which can be one of the following:

- FLOAT
- BOOST
- STC (Slope Thermal Compensation)
- BATT TEST

LEDs

Two rows of LEDs show the source and severity of various alarms. An alarm lights one status LED and one or more alarm LEDs. If more than one alarm LED lights, the status LED that lights will indicate the most severe active alarm.

- The first row includes four LEDs, labeled Alarm Status. They indicate the severity of the reported alarm:
 - Critical
 - Major
 - Minor
 - Normal

The Battery on Discharge LED is also in this row.

- The second row has seven LEDs, labeled Equipment Status. They indicate the source of the alarm:
 - AC System
 - Battery
 - Controller
 - Distribution
 - Rectifier
 - Remote Modules

The Modem LED illuminates when the internal modem is in use.

Test Jacks

A pair of test jacks allows direct measurement of the dc bus sense voltage being monitored by the controller.

Pushbutton Keys

A group of pushbutton keys below the backlit LCD display provides the primary user interface with the controller. These keys are used singly or in combination to navigate through the controller's menus.

The following is a general description of the pushbutton keys:

- ESCAPE: Return to the immediate higher level menu.
- HELP: Displays limited on-line help information.
- MENU: View the MAIN menu.
- ENTER: Select a menu item.
- Up arrow: Moves the cursor up one line.
- Down arrow: Moves the cursor down one line.
- Left arrow: Moves the cursor left one field.
- Right arrow: Moves the cursor right one field.
- + and -: Increase or decrease parameter values.
- Lamp test: Tests the controller's circuit board LEDs and front panel LEDs. It will also test the Indicators of serially connected rectifiers.

Access Panel

A rubber flap can be opened to access the local port connector. The DB-9 local port connector supports standard RS232 serial communication. Refer to the Galaxy Millennium II Controller product manual for additional details on port configuration and isolation.

Reference Material

Controller Product Manuals

A The Galaxy Millennium Controller product manual (Select Code 167-792-180) is furnished with every GPS 4827. Refer to this manual for information regarding configuration and operation.

RPM System Product Manual

Refer to the Galaxy Remote Peripheral Monitoring System product manual (Select Code 167-790-063) for additional information regarding module operation.

4. Rectifiers

NE050AC48ATEZ

Overview

The NE050AC48ATEZ Series rectifier (50A) operates from single-phase ac service with a phase-to-phase voltage within the range of 95 to 275Vac.

The rectifiers are shipped separately from the cabinets for quick and straightforward installation into rectifier shelves at the site. Interconnections to ac input, dc output, and control signals occur automatically during insertion. No settings or adjustments to potentiometers are necessary.

The NE050AC48ATEZ rectifiers are UL Recognized for both the U. S. and Canada, comply with UL1950 (Information Technology Equipment), and meet EN60950 requirements.

Front Panel Display

Status Indicators

Three LEDs on the rectifier's faceplate indicate the rectifier's condition.

- The Norm LED is green and is lit when the rectifier has AC input present and is working properly.
- The ACF LED is amber and is lit when there is no AC input present to the rectifier.
- The Fail LED is red and is lit if there is a failure in the rectifier.

Lamp Test

To test the LEDs on the rectifier front panel, press the Lamp Test button on the controller.

Features

Output Current “Walk-in”

This circuit controls the time (up to eight seconds) required for the rectifier to reach normal operating conditions after it is turned on. This feature minimizes the starting surge on the customer's power source.

Output Protection

Rectifier is equipped with an internal fuse for plant protection if a fault occurs in a rectifier.

Electronic Current Limit

When the output current tends to increase above the current limit set point, the current limit circuit overrides the voltage regulating signal and safely limits the output current of the rectifier, thus preventing damage to itself or the load.

High Voltage Shutdown (HVSD)

The rectifier senses the voltage at its output terminals. If this voltage is too high, the rectifier will shut down to prevent the high voltage from damaging itself or the load.

Restart

Upon shutdown, the rectifier will attempt to restart. The rectifier will also accept a restart command from the controller for a remote restart. The rectifier will attempt to restart three times before issuing a rectifier fail alarm to the controller.

Fan Alarm and Control

The rectifier contains a cooling fan. The fan's speed, which is based on ambient temperature and output power level, is lowered during low-load and low-temperature conditions to minimize audible noise and maximize fan life.

Thermal Alarm

The rectifier senses the internal operating temperature and will issue a thermal alarm if the internal temperature exceeds a safe operating level. Ambient temperatures above the maximum rating will result in a rectifier shutdown and the issuing of a thermal alarm (TA).

Autonomous Operation

Rectifiers will continue to power the load if the controller fails or if communication is lost.

Controller Communications Alarm

When communications between the rectifier and controller are interrupted, the rectifier continues to operate and the red Fail LED on the rectifier blinks.

Connectorized

The rectifiers provide the controller with a full complement of status and alarm signals. The rectifier status and alarm signals, ac input, and dc output are all connectorized for easy installation and maintenance. System connections are made when the rectifier is plugged into the shelf. No additional connections are required.

“Forced” Load Sharing

Internal rectifier circuitry will allow rectifiers to share load in the event communication to the controller is lost or the controller malfunctions.

This page intentionally left blank

5. AC Input Panels

Overview

AC Service

The ac input panel provides the facility to terminate 3-phase ac service to the GPS 4827 system or to distribute individual 1-phase ac supplies to each rectifier position. Depending upon the option ordered, the panel will connect 3-wire (three phases), 4-wire (three phases + neutral), or individual 2-wire (single phase, either 2 hot leads or 1 hot lead and neutral) input ac service.

Some options provide circuit breakers to protect the conductors providing ac service to the individual rectifiers. Other options provide a terminal strip and the conductors are protected by circuit breakers located in the building's ac service panel.

Note: See AC input table in the Specification section for recommended conduit size, wire size and protector size based on the National Electric Code.

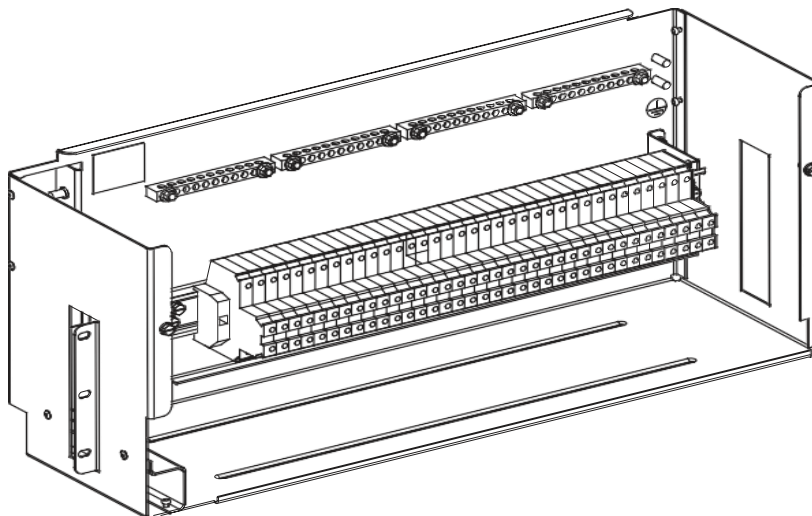

Figure 5-1: AC Input terminal strip panel

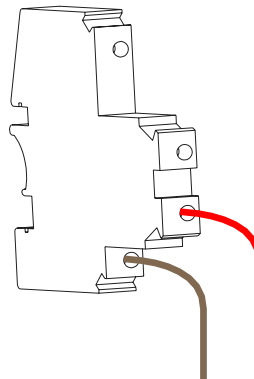

Figure 5-2: AC block.

Factory wiring from AC block to rectifier shelf shown.

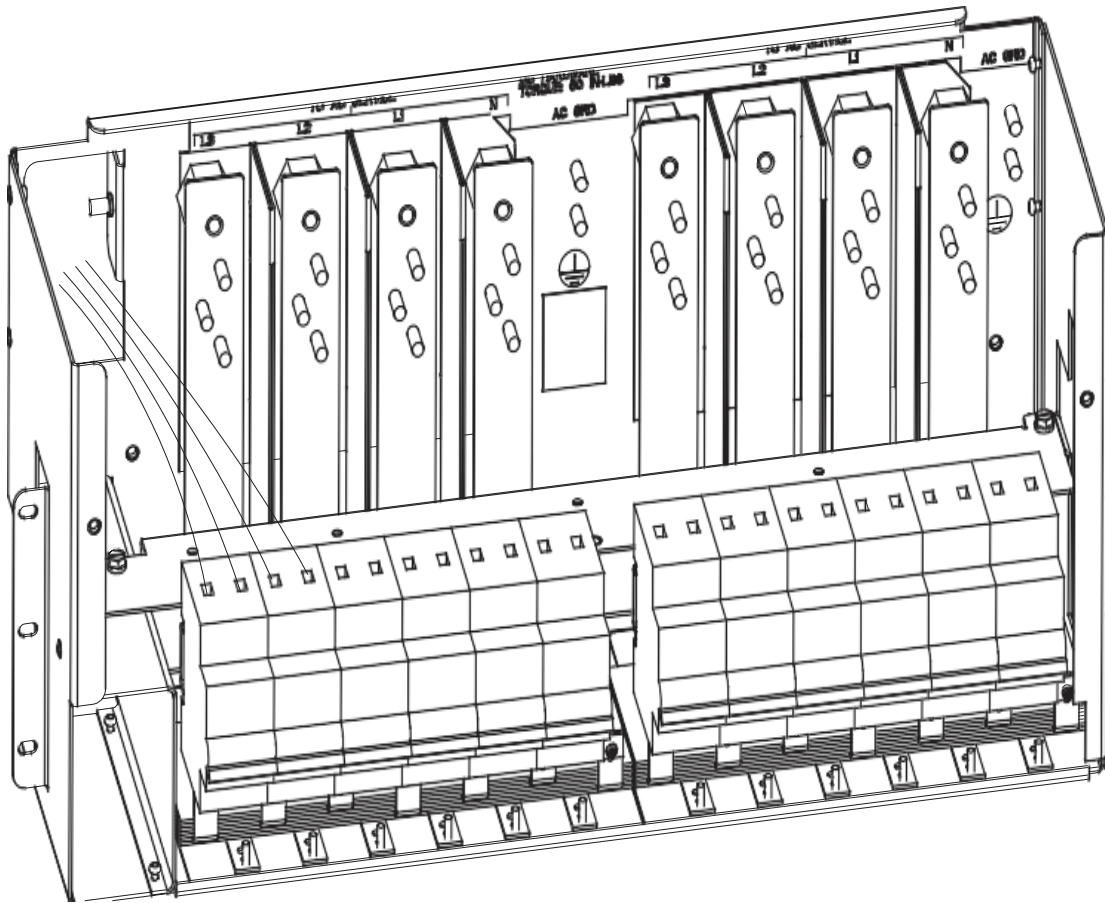

Figure 5-3: AC Input circuit breaker panel

CB1	CB2	CB3	CB4	CB5	CB6	CB7	CB8	CB9	CB10	CB11	CB12
G11	G12	G21	G22	G31	G32	G41	G42	G51	G52	G61	G62
G13	G14	G23	G24	G33	G34	G43	G44	G53	G54	G63	G64

Figure 5-3: AC Input circuit breaker panel

6. Battery Connection Panels

Overview

Function

Batteries are connected to the GPS 4827 cabinets on battery connection panels located in the cabinet directly below or behind the ac input panel. All panels include a battery shunt and an alarm card that communicates with the controller to provide battery current and status information. The optional panels may include a low voltage battery disconnect/reconnect (LVBD/R) contactor. When equipped with a LVBD/R, a contactor control card provides local manual control of the contactor.

Illustrations

The optional LVBD/R battery connection panel shown in Figures 6-1.

Note: Battery connection panels are blue; dc distribution panels are white.

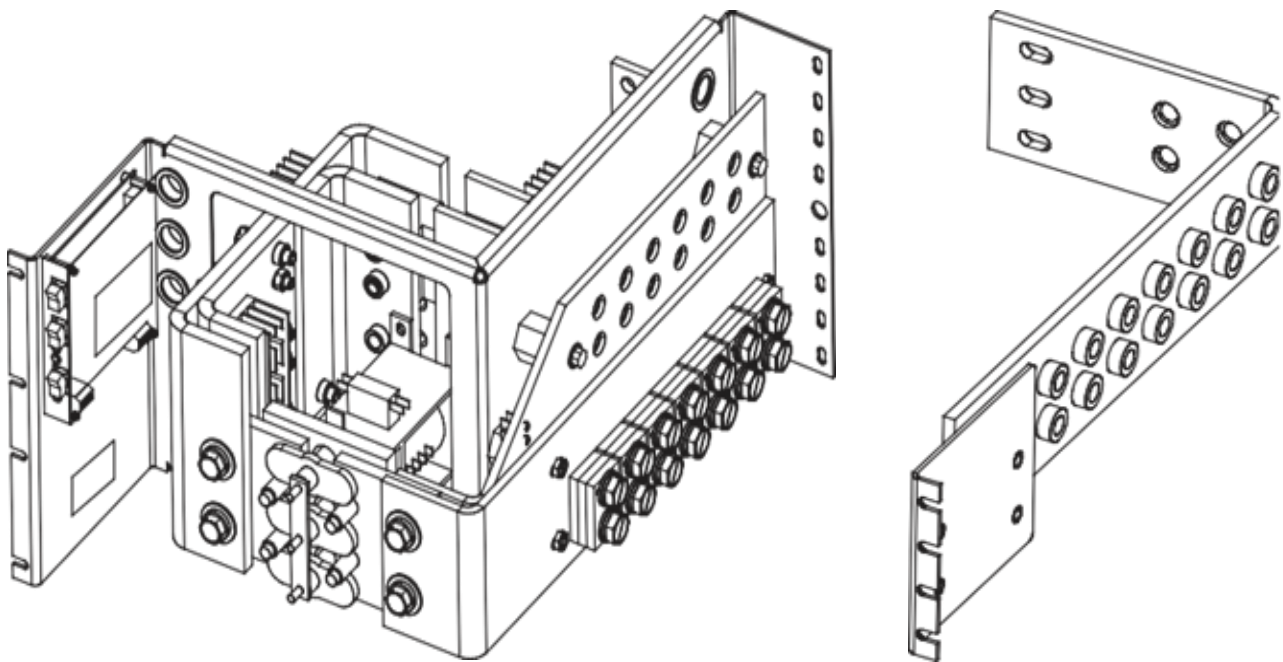

Figure 6-1: H5694827 G39 (ED83143-31 G36)
Optional Low Voltage Battery Disconnect/Reconnect LVBD/R panel.
 LVBD/R panel is equipped with a 2000 amp contactor and 3000 amp shunt to monitor battery charge/discharge current.

This page intentionally left blank

7. DC Distribution Panels

Function

A variety of dc distribution panels is available for the GPS 4827 system, including DIN standard fuse holders and circuit breakers and U. S. standard fuse holders and circuit breakers. All panels are equipped with an alarm card. When a fuse operates or a circuit breaker trips, a red LED on the alarm card lights, the cabinet alarm lights, and the alarm is transmitted to the controller. Distribution panels are also available with contactors to provide low voltage load disconnect.

Illustrations

The dc distribution panels are illustrated in Figures 7-1 through 7-11.

Note: DC distribution panels are white; battery connection panels are blue.

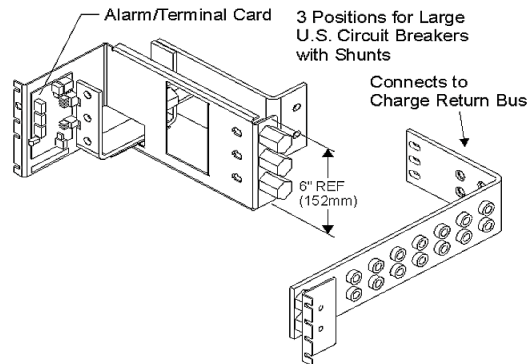

Figure 7-1: H569-4827 G42 (ED83143-31 G2) DC Distribution Panel

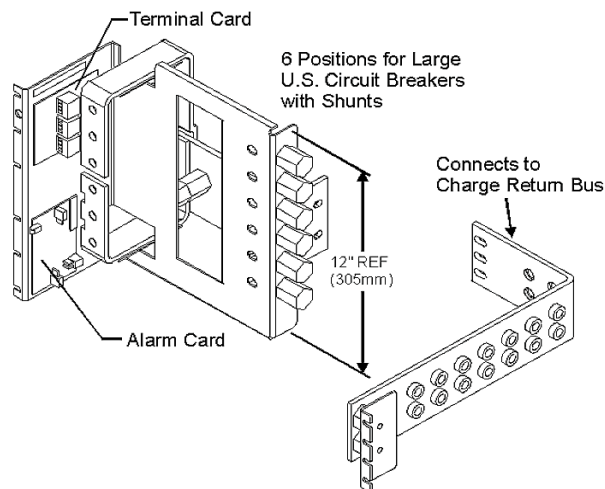
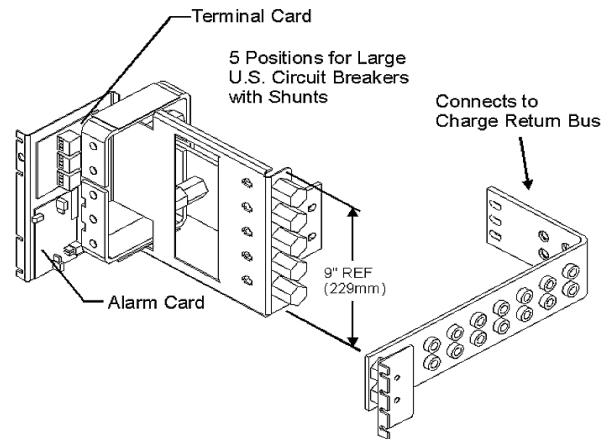

Figure 7-2: H569-4827 G43 (ED83143-31 G1) DC Distribution Panel



**Figure 7-3: H569-4827 G48 (ED83143-31 G5)
DC Distribution Panel**

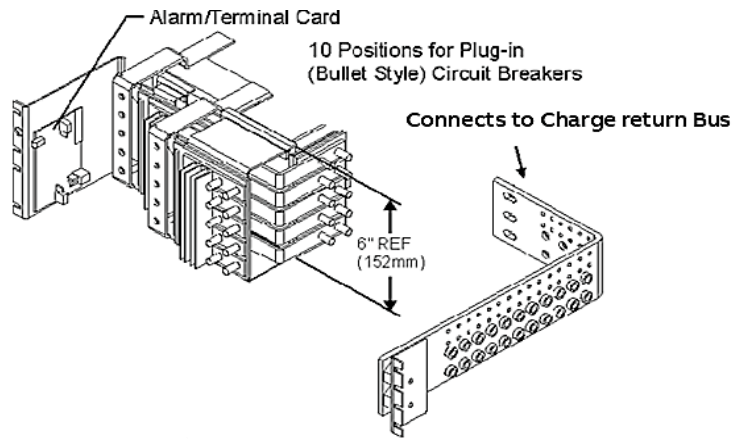
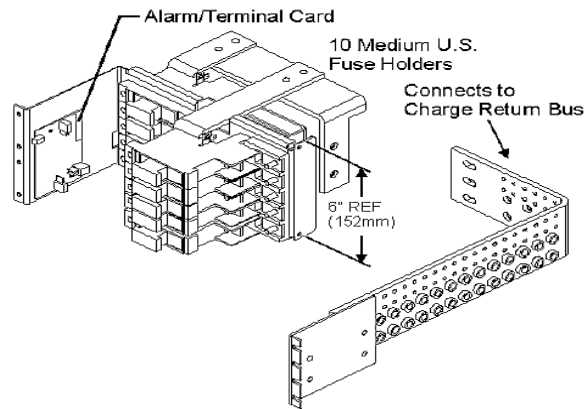

Figure 7-4: H569-4827 G96 (ED83143-31 G15) DC Distribution Panel



**Figure 7-5: H569-4827 G52 (ED83143-31 G53)
DC Distribution Panel**

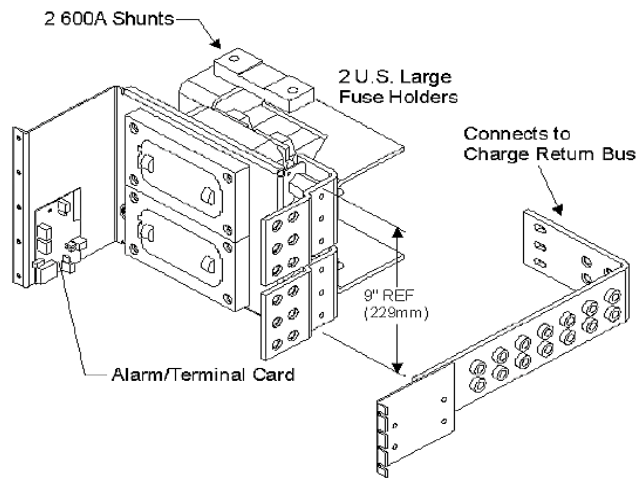

Figure 7-6: H569-4827 G53 (ED83143-31 G55) DC Distribution Panel

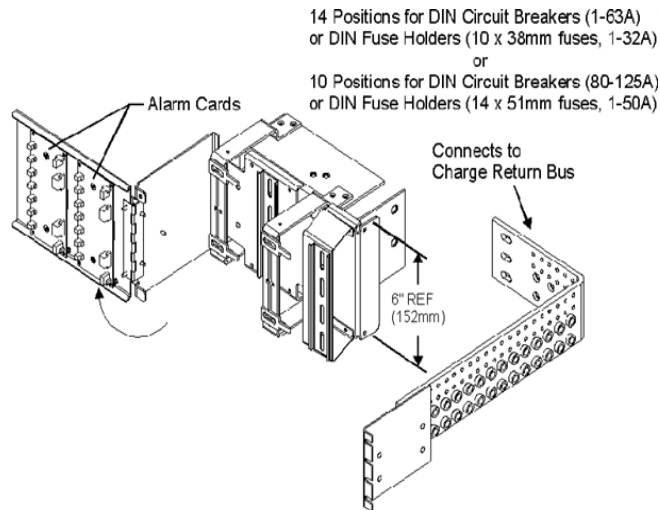

Figure 7-7: H569-4827 G60/61/65/66 (ED83143-31 G71) DC Distribution Panel

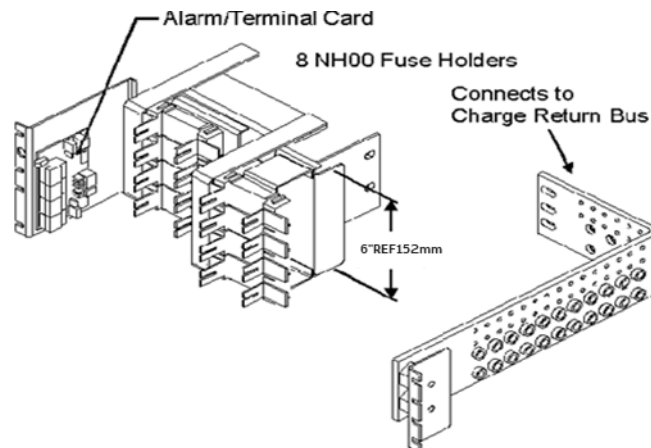

Figure 7-8: H569-4827 G67 (ED83143-31 G22) DC Distribution Panel

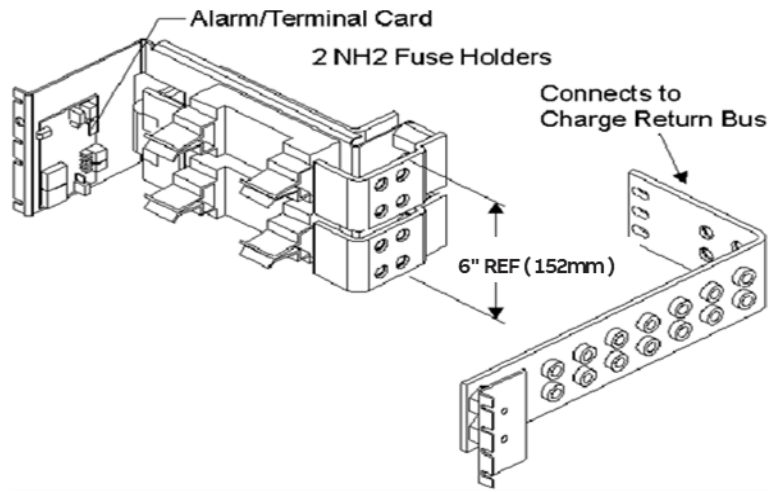

Figure 7-9 H569-4827 G68 (ED83143-31 G21) DC Distribution Panel

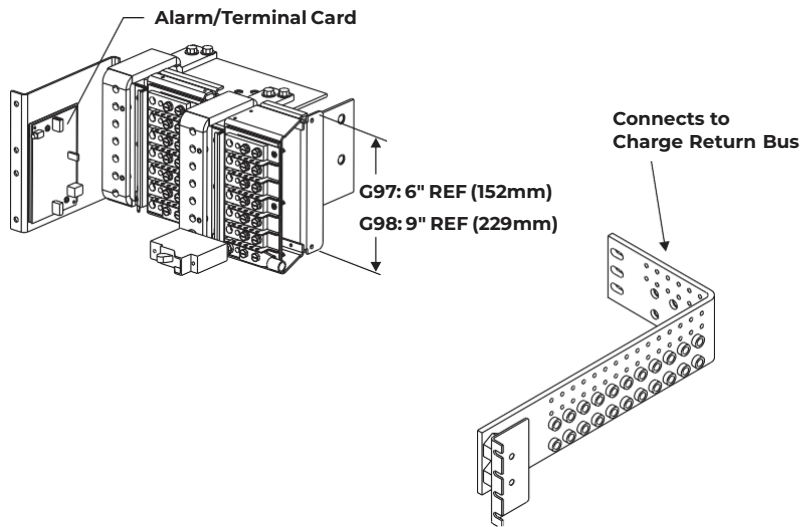

Figure 7-10 H569-4827 G97, G98 (ED83143-31 G17) DC Distribution Panel

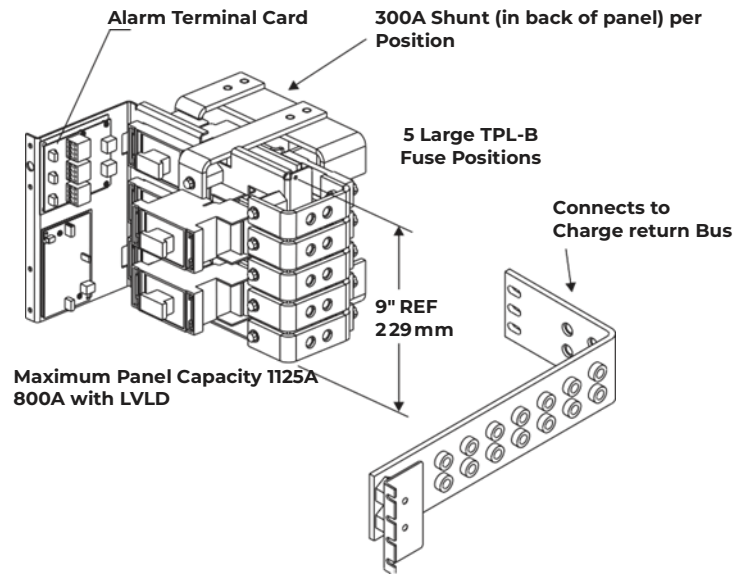

Figure 7-11 H569-4827 G54 (ED83143-31 G21) DC Distribution Panel

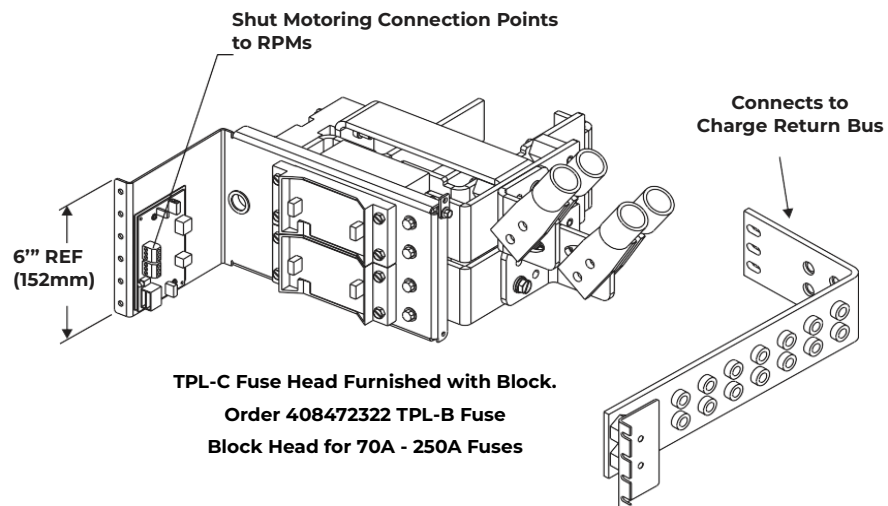

Figure 7-12 H569-4827 G59 (ED83143-31 G21) DC Distribution Panel

This page intentionally left blank

8. External Return Bars

Overview

Modular external return bus bar kits are available for the GPS4827 system. These kits are alternatives to the standard internal return buses. These kits allow for modular growth of the bars from bay to bay and offer additional cable landings.

Illustrations

The dc distribution panels are illustrated in Figures 9-1 through 9-11.

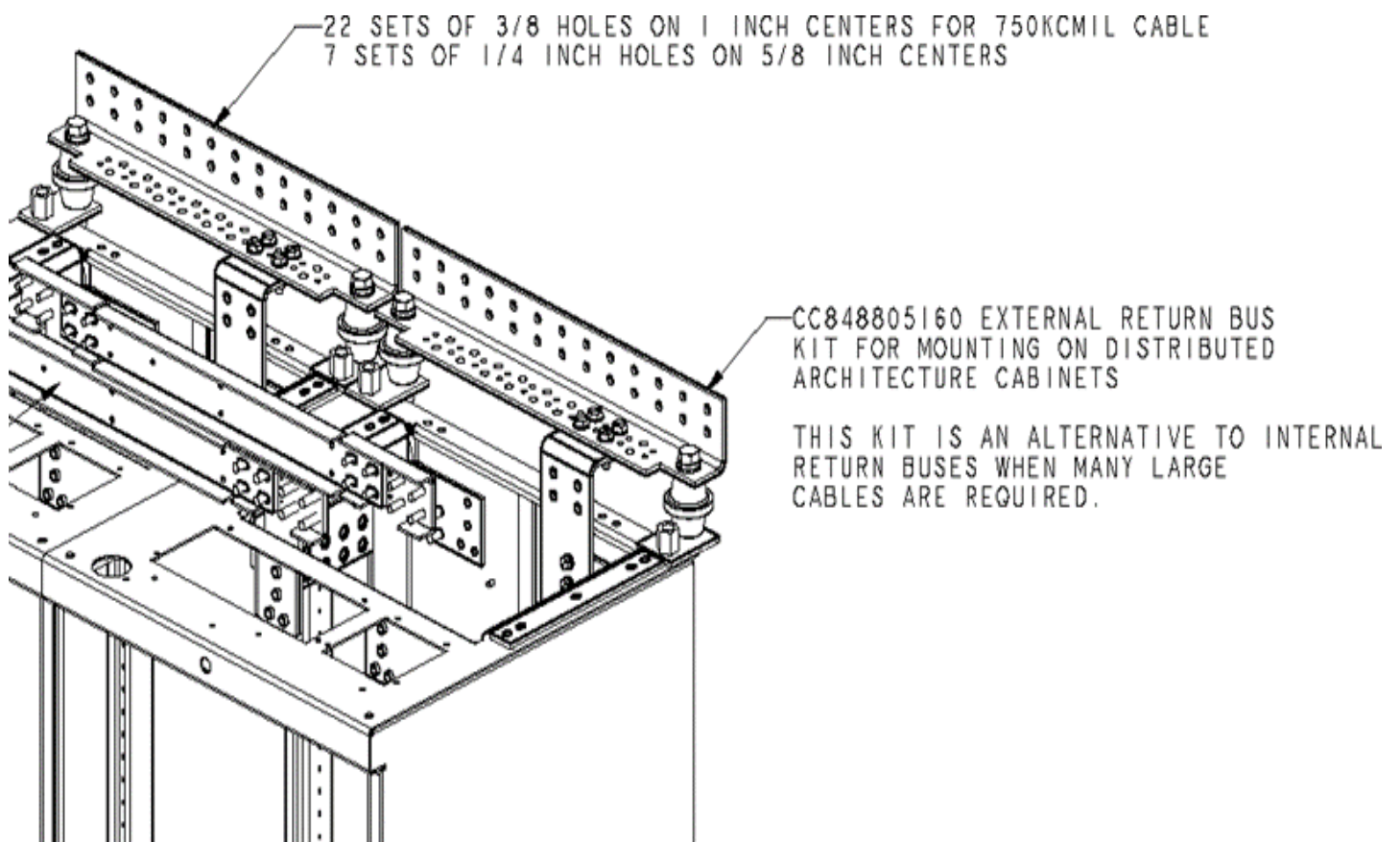
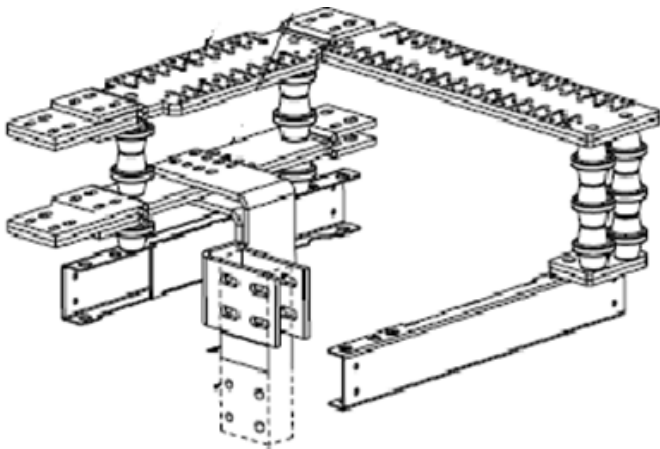
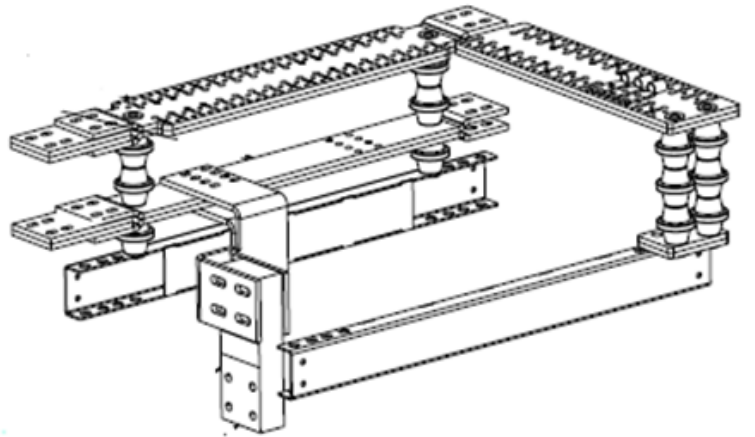

Figure 8-1 Standard Architecture 600mm External Return Bus Kit CC848805160 for distributed architecture cabinets



TBD Standard Bay



TBD Wide Bay

Modular Distribution Bay Overhead Buses

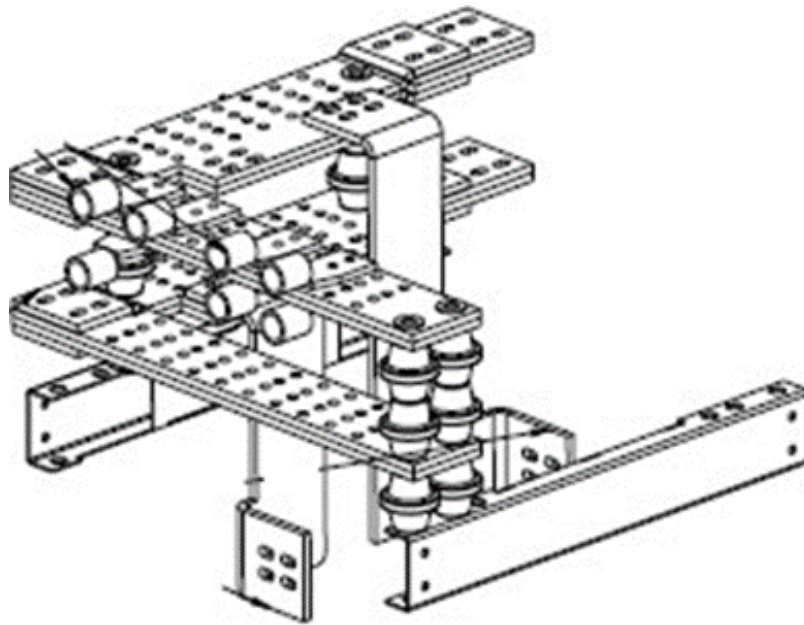

TBD Modular Rectifier Bay Overhead Bus

Figure 8-2 Horizontal Rectifier Standard and Wide Distribution Bay bus bar system

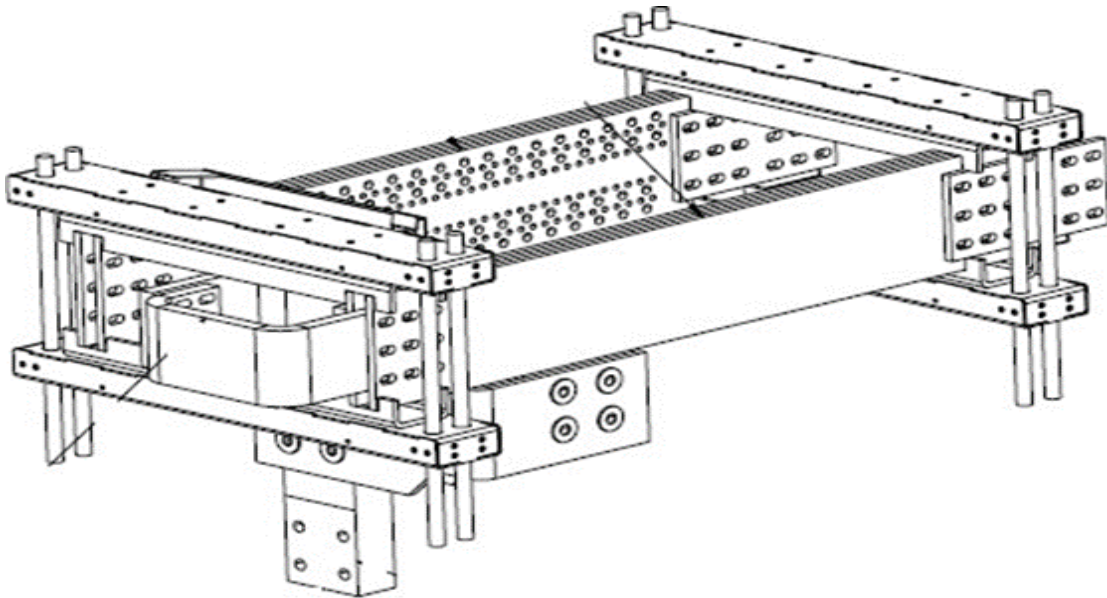

TBD Modular Distribution Wide Bay Overhead Bus

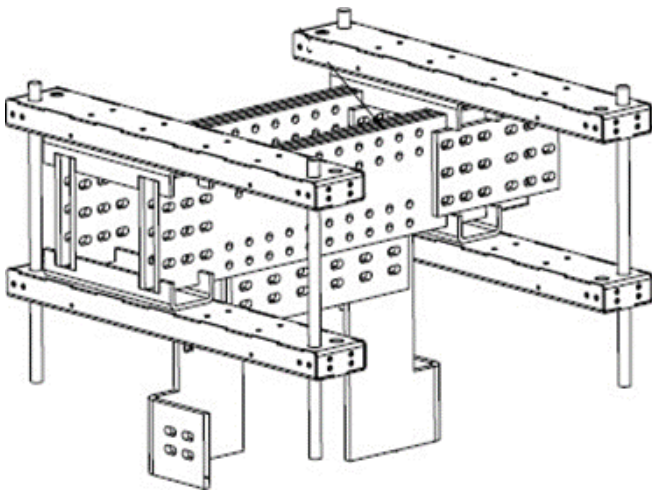

Field Option A

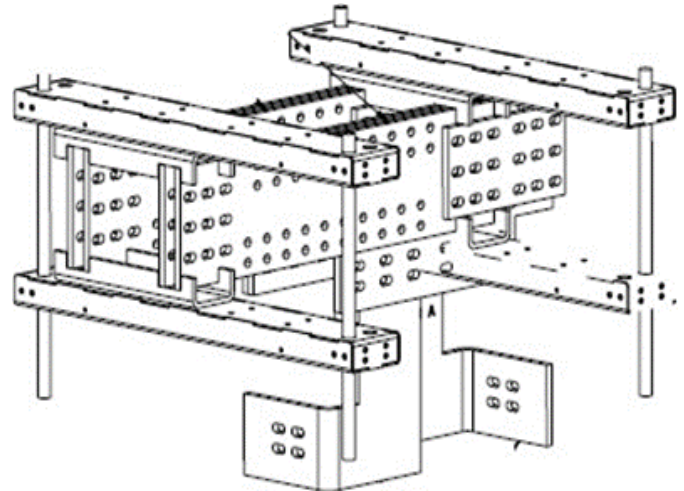

Field Option B

TBD Rectifier Bay Overhead Bus
Figure 8-3 Vertical rectifier standard and
wide distribution bay return bus bar systems

This page intentionally left blank

9. Millennium II Controller Operation

The Millennium II is factory pre-installed and pre-configured with industry standard defaults for thresholds and feature operability in GPS cabinet applications. In addition, customer specific default controller settings may be available upon request. This section provides:

Preparation and Precautions
Procedures for the proper addition of optional packs
Input and output wiring to the controller and the installation and wiring of optional features
Controller default configuration information such as alarm severity and description, system voltage, shunt information
Controller configuration information

Preparation

<p>The following Installation procedures should be performed AFTER:</p>	<ul style="list-style-type: none"> All the equipment frames (initial and supplemental bays, free-standing rectifiers, etc.) are anchored in place. The battery stands have been erected and the batteries installed The overhead cable racks have been installed and the power cables have been run and terminated. The plant's charge and discharge bus bar assemblies have been installed.
<p>But BEFORE:</p>	<ul style="list-style-type: none"> Connecting the batteries to the plant charge and discharge bus bars or turning up the plant rectifiers.

Precautions

- Observe ESD protection while installing circuit packs.
- Wear grounded antistatic wrist straps when handling all circuit packs. The wrist strap must contact the skin and is not to be worn over clothing.
- Never hand a circuit pack from a grounded to a non-grounded person or vice-versa.

Safety

Action	Verified
Always consider personal safety before beginning any procedure. Review the Safety section.	
Be aware of the presence of unfused battery potential in the vicinity of the controller.	
Use only insulated tools.	
Make sure the system is properly grounded per the National Electrical Code and local building codes.	
Remove all metal jewelry before beginning the installation.	

Installation Materials

Item	Verified
Wire cutters and strippers	
18 to 22 AWG wire	
Jewelers screwdriver (Flat and Phillips)	
Small needle nose pliers	
Digital meter, +/- 0.02%	
Screw Drivers (flat-blade and Phillips)	
ESD wrist strap	
Wire-wrap tool or Amp alarm punch-down tool	

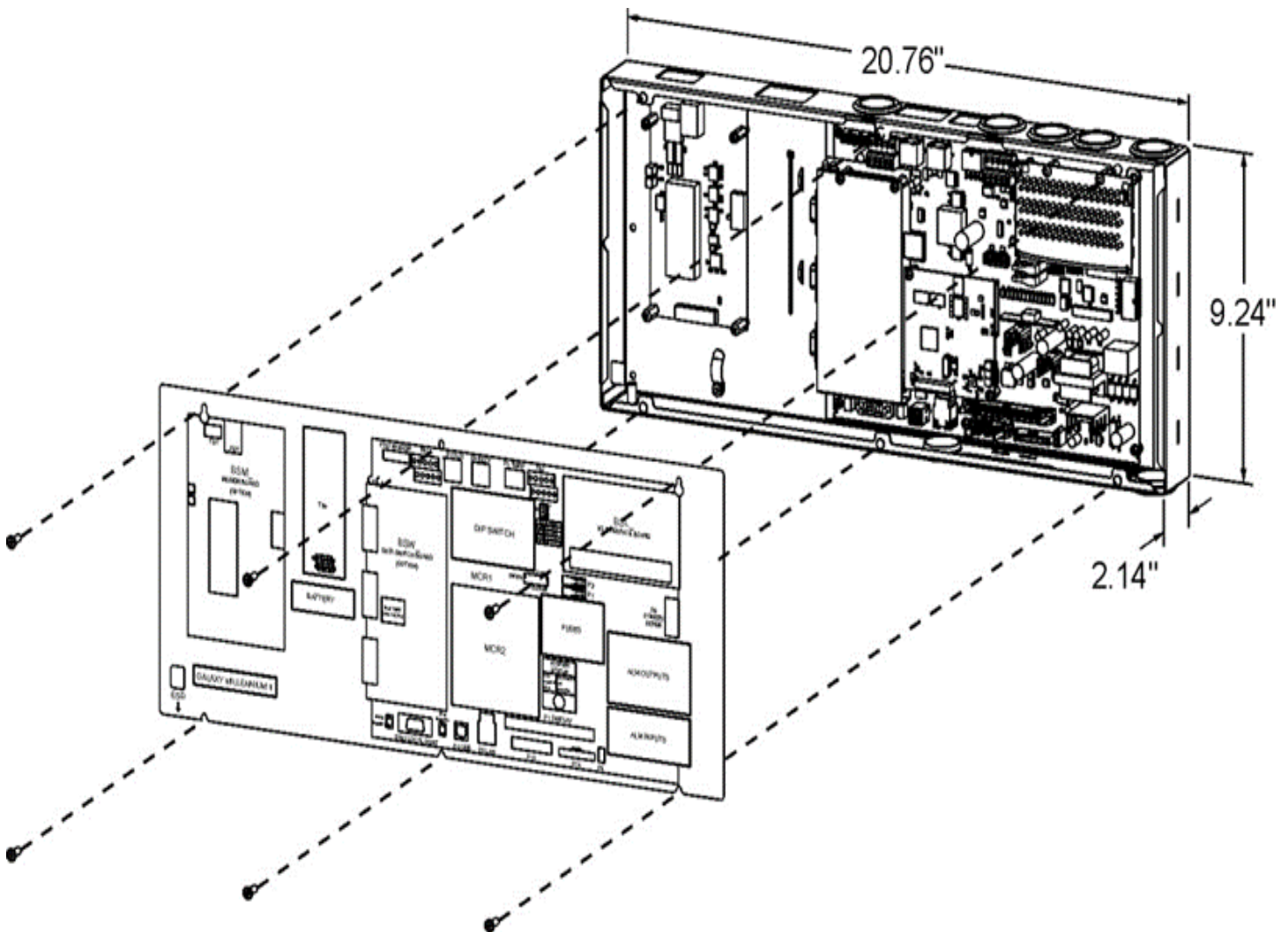

Figure 9-1: Millennium II

Controller Connections

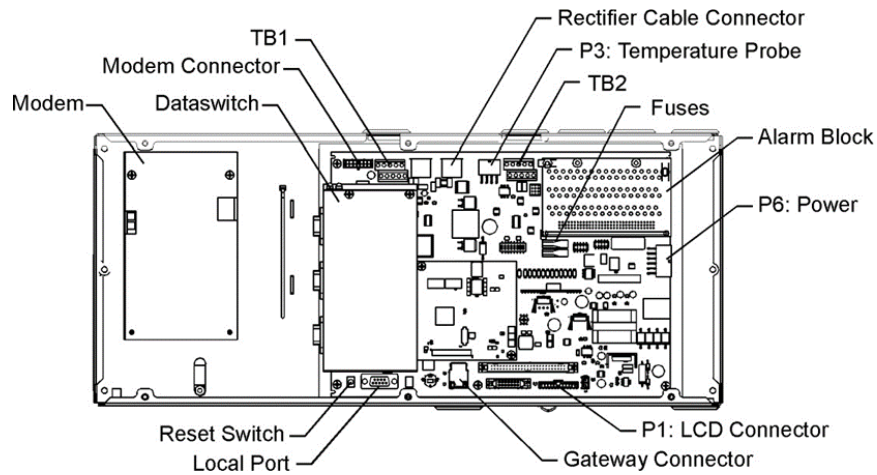

Figure 9-2: Millennium II Controller Connections

Interface Reference	Description
P1	Connectorized interface for large parallel format 8x40 LCD assembly
P2	10/100 Base-T LAN/Ethernet interface
P3	Connectorized interface for 10K/30K thermistor probe options or 210E
P6	Connectorized input for input power, monitoring of two shunts, plant sense voltage, and Major Fuse alarm (Same connection as on the Millennium)
p7	RJ45 receptacle for ground referenced Auxiliary RS485 circuit and One-Wire temperature monitoring devices
P8	BSL1-4 circuit pack Interface connector for Input/Output to controller
p9	RJ45 receptacle for isolated RS485 system component monitoring and control of rectifiers, converters, low voltage disconnect contactors, and bay level alarm inputs (Serial Rectifier bus)
P13	Factory test connector (not used in the field)
P14	Connectorized interface for future smaller serial format LCD
P15	Connectorized interface for future smaller serial format LCD
P201	Connectorized interface for optional Modem
P202	Ground referenced DB-9 for local RS232 serial port
P205	Option board connector
TB1	Terminal block interface for RS232/RS485 Auxiliary port and Remote Peripheral Module(RPM) connections
TB2	Terminal block interface for three additional 10K thermistor probe or 210E connection options
J10	USB interface (reserved for future use)

Table 9-A: Millennium II Interface Reference

Installation Circuit Packs

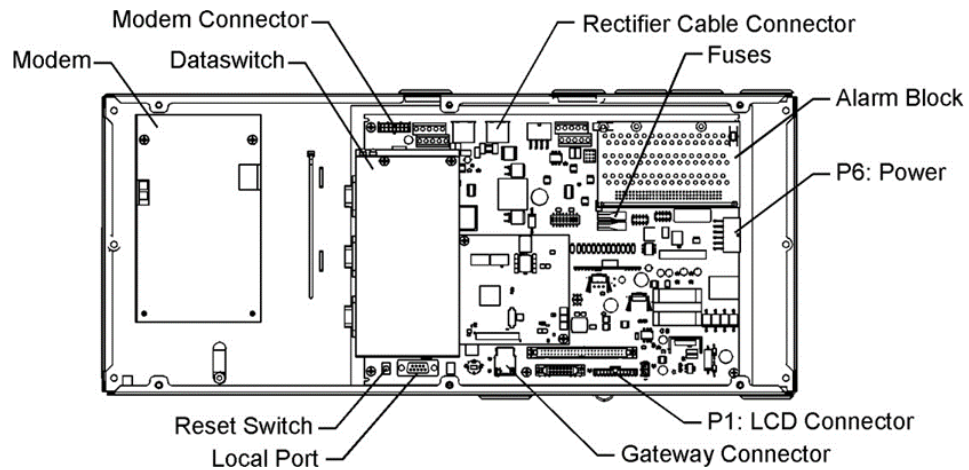

Figure 9-3: Millennium II Controller Connections

Modem Card

The optional Modem card may require field installation. To do so, perform the following steps:

Step	Action
NOTE:	Installation or replacement of this pack can be done “hot”; power removal is not necessary.
1.	Remove the controller front cover.
2.	Install the BSM on the 4 standoffs, to left of the controller MCR1 board using four 845143866 screws.
3.	Connect the 848091798 cable assembly between the BSM J100 plug and P201 on the MCR1 board.
4.	<p>Note: This step may be performed at a later time</p> <p>Install phone line wiring from Connect the existing telephone cable to the RJ11 connector at the top of the board</p> <p>OR</p> <p>Connect Tip/Ring conductors to TB1 at the top of the board.</p> <p>NOTE: Tip is TB1 pin 1 (Pin closest to the RJ11 connector) and Ring is Pin 3. Pin 2 is not used.</p>
5.	Operate the reset switch on the MCR1 board in the lower left corner of the MCR1 board. (see Figure 4-3)
NOTE:	The Password Reset button is to the LEFT of the serial port connector, and the Controller Reset is to the right of the serial connector.

Data Switch Card

Step	Action
NOTE:	Installation or replacement of this pack can be done “hot”; power removal is not necessary.
1.	Install two 407882133 standoffs on the BSJ intelligent board. Screw threads are protruding just below TB1, located at the upper left hand corner of the MCR1 board.
2.	Place BSW pack inside the 847950938 insulator.
3.	Plug BSW pack into the P205 connector on the BSJ intelligent controller board
4.	Secure the BSW board to the standoffs with two 900562208 screws.
NOTE:	To install the Data Switch Extension board, please see the User’s Guide for Millennium II Controller Advanced Features manual.

Alarm Termination Board

Alarm Termination board options provide for wire wrapped or insulation displacement (punch down) terminations. The Alarm Termination Board for a specific application may require field installation. To do so, perform the following steps:

Step	Action
1.	In the upper right hand corner of the MCR1 board, find the alarm board already installed.
2.	Remove the two screws holding the board at the top.
3.	Holding the board on both sides, slowly, but firmly, remove the alarm board from the P8 connector.
4.	Unpack the new board from its box, carefully observing proper ESD procedures.
5.	Connect the alarm board to P8 and press down firmly, until the board is seated.
6.	Secure the alarm board at the top using the two screws removed earlier.

Gateway (LAN) Connection

Step	Action
NOTE:	The Gateway card has been designed into the MCR1/MCR2 boards and requires no additional circuit packs.
NOTE:	The Gateway has an IEEE 802.3 compliant 10Base-T network interface. Since the cable length required to connect to the network is variable, this cable must be supplied by the user.
1.	At the controller, connect one end of the network interface cable to P2. This connector is located at the bottom center of the MCR1 board, and immediately below the MCR2 board.
2.	Connect the other end to an IEEE 802.3 compatible network.
3.	Configure the Gateway for the network by contacting the customer's network administrator. Detailed configuration information may be found in the User's Guide for Millennium II Controller Advanced Features manual.

Rectifier Cabling

Step	Action
NOTE:	For new installations, the Millennium II rectifier cabling has been factory wired and installed to the cabinet BIC/BLJ board for alarm and rectifier communication.
NOTE:	For connector integrity, verify that the cable is installed and connected properly.
1.	Verify that the rectifier cable is connected to P9, and NOT P7(AUX) cable connector.
2.	Verify that the cable connector is properly seated into P9, and that it is not loose.
3.	Verify that the rectifier cable terminating on the BIC/BLJ board is connected to P9 and also not loose.

Remote Peripheral Monitoring (RPM)

RPM provides data acquisition capability far beyond that normally available in a power system controller. Monitoring modules available consist of:

- Shunt monitors (6 channels + 1 temperature channel)
- 0-100mV dc Voltage monitors (6 channels + 1 temperature channel)
- 0-3V dc Voltage monitors (6 channels + 1 temperature channel)
- 0-16V dc Voltage monitors (6 channels + 1 temperature channel)
- 0-200V dc Voltage monitors (6 channels + 1 temperature channel)
- Temperature monitor (7 Channels)
- Control Relay module (3 sets of programmable form C relay outputs)

Remote Peripheral Monitoring (RPM) (continued)

The user may connect a maximum of 95 of any combination of these modules serially.

Step	Action																
NOTE:	The Remote Peripheral Monitoring feature has been designed into the MCR1 board and requires no additional circuit packs. Monitoring and control modules ARE required, based on the application.																
NOTE:	This section only describes a single module connection to the controller. Modules MUST BE PROGRAMMED after they have been installed or they may not function properly. Detailed connection and configuration information may be found in the User's Guide for Millennium II Controller Advanced Features manual.																
1.	Using the RPM bus cable (Ordering Code 407377704), wrap the cable through the EMI inductor bead twice. Place the bead approximately 3 inches from the end of the cable.																
2.	Connect the bus cable to:																
	<table border="1"> <thead> <tr> <th>TB-1 Pin Assignments</th> <th>TP-1 Pin Description</th> <th>RPM Conductor Color</th> <th>RPM Conductor Description</th> </tr> </thead> <tbody> <tr> <td>6</td> <td>*6</td> <td>Blue or White</td> <td>Power /Communications</td> </tr> <tr> <td>8</td> <td>*8</td> <td>Blue or White</td> <td>Power /Communications</td> </tr> <tr> <td>9 or 10</td> <td>FGND</td> <td>Blue or White</td> <td>Shield</td> </tr> </tbody> </table>	TB-1 Pin Assignments	TP-1 Pin Description	RPM Conductor Color	RPM Conductor Description	6	*6	Blue or White	Power /Communications	8	*8	Blue or White	Power /Communications	9 or 10	FGND	Blue or White	Shield
	TB-1 Pin Assignments	TP-1 Pin Description	RPM Conductor Color	RPM Conductor Description													
	6	*6	Blue or White	Power /Communications													
	8	*8	Blue or White	Power /Communications													
9 or 10	FGND	Blue or White	Shield														
*connections of the bus wire are NOT polarity sensitive.																	
3.	Secure the module connection unit and route the wires through the open-faced bottom of the connection unit.																
4.	Make the connections to TB2 on the connection unit:																
	<table border="1"> <thead> <tr> <th>TB-2 Pin Assignments</th> <th>RPM Conductor Color</th> <th>RPM Conductor Description</th> </tr> </thead> <tbody> <tr> <td>IN</td> <td>Blue or White</td> <td>Power /Communications</td> </tr> <tr> <td>OUT</td> <td>Blue or White</td> <td>Power /Communications</td> </tr> <tr> <td>SHIELD</td> <td>Bare Wire</td> <td>Shield</td> </tr> </tbody> </table>	TB-2 Pin Assignments	RPM Conductor Color	RPM Conductor Description	IN	Blue or White	Power /Communications	OUT	Blue or White	Power /Communications	SHIELD	Bare Wire	Shield				
	TB-2 Pin Assignments	RPM Conductor Color	RPM Conductor Description														
	IN	Blue or White	Power /Communications														
	OUT	Blue or White	Power /Communications														
SHIELD	Bare Wire	Shield															
*Connections of the bus wire are NOT Polarity Sensitive																	
* there are 2 IN, and 2 OUT connections. Either one may be used.																	
5.	Locate the control unit. This is the half with circuitry on it.																
6.	In the lower right hand side of the control unit (inside), are two rotary switches. Set SW-1 (LO) to 1. The module will be recognized as 01 by the controller. Other modules added cannot have the same address or 00 for the address.																
7.	Carefully attach the control unit to the connection unit using the ribbon connector.																
NOTE:	This connector/cable is not keyed, so be careful to line up the pins properly.																
8.	After approximately 1 minute, the green LED on the front of the module will blink once approximately every 5 seconds. Detailed troubleshooting information may be found in the User's Guide for Millennium II Controller Advanced Features manual.																

Thermal Probe

Without thermal probes, many of the controller's battery management features will not function, or produce erroneous results. Some features requiring thermal inputs are:

- Slope Thermal Compensation
- Reserve Time Prediction
- High Temperature Alarm
- Ambient High and Low Temperature Alarms
- High Temperature Disconnect

Step	Action			
NOTE:	The controller supports a number of thermal probe inputs. The type of probe used determines where it is connected on the controller. Detailed thermal probe and battery management information may be found in the User's Guide for Millennium II Controller Advanced Features manual.			
1.	The following table shows the type of probe and connector location on the Millennium:			
	Type of Probe	Ordering Code	Controller Connection Location	
	10/30K		P3	
	210E Thermal Probe Mux		P3	
	1 Wire Temperature Monitoring Devices		P7	
	Terminal Block Interface for 3 additional 10k probes or 210E connection		TB2	
			Pin	Description
			1	Probe 2
2			Probe 2 RTN	
3			Probe 3	
4			Probe 3 RTN	
5	Probe 4			
6	Probe 4 RTN			

USB Interface

This interface is reserved for future use.

Local Port

Software

EasyView software is a Windows-compatible communications package designed specifically for use with Galaxy controllers. Download EasyView software from [omnionpower.com](https://www.omnionpower.com)

Wiring Alarm Outputs

These external alarms may be wired to customer external office alarms at their destination.

Form-C Alarm Contact Ratings	60Vdc, 0.3A
Conductor Size for terminating on Alarm board	18 – 22AWG (if less than 18AWG, use multi-conductor cable for mechanical integrity)

Refer to Table 4-B and 4-C for lead designations and their descriptions for leads terminating on the BSL alarm interface board.

Pin Number	Signal Name	Pin Number	Signal Name	Pin Number	Signal Name
1	PCRAO	33	MJFR	65	FAN
2	PCRAC	34	MNFR	66	AMN
3	PCRAR	35	MNFC	67	TFLT
4	PCRVR	36	MNFO	68	TBST
5	PCRVC	37	BDO	69	TRTN
6	PCRVO	38	BDC	70	PBTR
7	PCREO	39	BDR	71	PBT
8	PCREC	40	ACFR	72	OS

Table 9-B Controller Alarm Descriptions and Pin Numbers

Controller Alarm Descriptions and Pin Numbers (continued)

Pin Number	Signal Name	Pin Number	Signal Name	Pin Number	Signal Name
9	PCRER	41	ACFC	73	TR1
10	PMJAR	42	ACFO	74	TEQ
11	PMJAC	43	RFAO	75	ETR
12	PMJAO	44	RFAC	76	ETRR
13	PMJEO	45	RFAR	77	RO
14	PMJEC	46	HVR	78	ROR
15	PMJER	47	HVC	79	TR2
16	PMJVR	48	HVO	80	TR4
17	PMJVC	49	UR1O	81	RBRPO
18	PMJVO	50	UR1C	82	TBD now general I/O-1
19	PMNAO	51	UR1R	83	USRIPRESENT/BTP now general I/O-2
20	PMNAC	52	CTLRR	84	LVD1
21	PMNAR	53	CTLRC	85	TR3
22	PMNVR	54	CTLRO	86	-
23	PMNVC	55	UR2O	87	4-20mA in
24	PMNVO	56	UR2C	88	4-20mA Rtn
25	5V	57	UR2R	89	USR3PRESETN/BTPFLT now general I/O-3
26	-	58	UR3R Now VLVR	90	USR3DETECT/BTMJ
27	-	59	UR3C Now VLVC	91	0-5V in
28	PMNER	60	UR3O Now VLVO	92	0-5V Rtn
29	PMNEC	61	LVD2	93	ABS
30	PMNEO	62	LVD2R	94	ABS
31	MJFO	63	FAJ	95	DG
32	MJFC	64	AMJ	96	DG

Critical-Audio	1	PCRAO
	2	PCRAC
	3	PCRAR
Critical-Visual	4	PCRVR
	5	PCRVC
	6	PCRVO
Critical-External	7	PCREO
	8	PCREC
	9	PCRER
Power Major-Audio	10	PMJAR
	11	PMJAC
	12	PMJAO
Power Major –External	13	PMJEO
	14	PMJEC
	15	PMJER
Power Major –Visual	16	PMJVR
	17	PMJVC
	18	PMJVO
Power Minor-Audio	19	PMNAO
	20	PMNAC
	21	PMNAR
Power Minor –Visual	22	PMNVR
	23	PMNVC
	24	PMNVO
Power Minor –External	28	PMNER
	29	PMNEC
	30	PMNEO
Major Fuse	31	MJFO
	32	MJFC
	33	MJFR
Minor Fuse	34	MNFR
	35	MNFC
	36	MNFO
Battery On Discharge	37	BDO
	38	BDC
	39	BDR

AC Fail	40	ACFR
	41	ACFC
	42	ACFO
Rectifier Fail	43	RFAO
	44	RFAC
	45	RFAR
High Voltage	46	HVR
	47	HVC
	48	HVO
User Relay 1	49	UR1O
	50	UR1C
	51	UR1R
Controller Fail	52	CTLRR
	53	CTLRC
	54	CTLRO
User Relay 2	55	UR2O
	56	UR2C
	57	UR2R
Very Low Voltage	58	VLVR
	59	VLVC
	60	VLVO

Wiring Alarm and Control Inputs

In a standard Galaxy Power System configuration, plant level alarms are sent to the controller via the Bay Interface Card through serial data communication. The following alarm inputs are provided for discretionary use in non-standard applications.

Alarm	Pin Number	Signal Name
Low Voltage 2 Disconnect State Detect	61	LVD2
Fuse Alarm Major	63	FAJ
Fuse Alarm Minor	65	FAN
Auxiliary Alarm Major	64	AMJ
Auxiliary Alarm Minor	66	AMN
Timer Float Control	67	TFLT
Timer Boost Control	68	TBST
Plant Battery Test	71	PBT
Open String Detect	72	OS
Transfer Rectifier 1	73	TR1

Alarm	Pin Number	Signal Name
General Purpose Input 4	74	IN-4 previously TEQ
General Purpose Input -5 (Previously Engine Transfer)	75	IN-5 Previously ETR
Reserve Operation	77	RO
Transfer Rectifier 2	79	TR2
Transfer Rectifier 4	80	TR4
Reserve Battery-Emergency Power Off	81	RBRPO
General Purpose Input 1	82	IN-1
BTP or General Purpose Input 2	83	IN-2/BTP
Low Voltage 1 Disconnect State Detect	84	LVD1
Transfer Rectifier 3	85	TR3
General Purpose 4-20mA Measuring Circuit	87	4-20mA
General Purpose 4-20mA Measuring Circuit-RTN	88	4-20mAR
BTPFLT or Generic Input 3	89	IN-3/ BTPFLT
Low Voltage 3 Disconnect State Detect Also Battery Thermal Protect Major	90	LVD3/ BTMJ
General Purpose 0-5Vdc Measuring Circuit	91	0-5V
General Purpose 0-5Vdc Measuring Circuit-RTN	92	0-5VR

BSL-63 FAJ: Fuse Alarm Major

An optional battery potential input, must use an external 1K ohm 2W current limiting resistor at the source. A Fuse Alarm Major is generated when battery potential is received.

BSL-65 FAN: Fuse Alarm Minor

A battery potential input is required, which must use an external 1K ohm, 2W current limiting resistor at the source. A Fuse Alarm Minor is generated when battery potential is received.

BSL-72 OS: Open String Alarm

A battery potential input is required, which must use an external 1K ohm 2W current limiting resistor at the source. This circuit is used to signal Galaxy that a battery string protective device or switch is in the open position. An Open String Alarm is generated when battery potential is received.

BSL-64 AMJ: Aux Major

A battery potential input is required, which must use an external 1K ohm, 2W current limiting resistor at the source. This circuit is used to allow Galaxy to monitor another power device and provide alarms for it. An Aux Major Alarm is generated when battery potential is received.

BSL-66 AMN: Aux Minor

A battery potential input is required, which must use an external 1K ohm, 2W current limiting resistor at the source. This circuit is used to allow Galaxy to monitor another power device and provide alarms for it. An Aux Minor Alarm is generated when battery potential is received.

LVD1: BSL-84 Low Voltage Disconnect Active

A battery potential input is required, which must use an external 1K ohm, 2W current limiting resistor at the source if not using standard OmniOn Power LVD circuit boards or controller. This circuit is used to inform Galaxy that the monitoring circuit of a Low Voltage Disconnect device has failed. In standard Galaxy Power Systems, the Bay Interface board monitors these alarms and informs the Controller through the serial interface connection.

LVD2/LVD2R: BSL-61/62 Low Voltage Disconnect Active

A closure between these points or a ground signal into LVD2/ BSL-61 is used to inform Galaxy that the a Low Voltage Disconnect device has opened. In standard Galaxy Power Systems, the Bay Interface board monitors these alarms and informs the Controller through the serial interface connection.

External Boost Option

A variety of external devices may be used to initiate boost in Galaxy. Wiring is required from positions 67/68/69 on the BSL board for operation of this feature. Providing a contact closure between TBST and TRTN initiates the boost feature. A contact closure between TFLT and TRTN returns the plant to float. Additional information on External Boost can be found in the User's Guide for Millennium II Controller Advanced Features manual.

Rectifier Sequence Option

The controller is capable of sequencing rectifiers on line after detecting a AC is being provided by emergency generator. Internal Rectifier Sequencing requires external wiring to ETR/ETRR on BSL pin numbers 75/76, and optionally RO/ROR on BSL pin numbers 77/78, in order to function.

The controller can also accept ground signals onto TR1 to TR4 on BSL 73/79/ 85/80 from an external device to control the sequencing of plant rectifiers in groups as follows:

Additional information on the Rectifier Sequence Options can be found in the User's Guide for Millennium II Controller Advanced Features manual.

TR Signal	Rectifiers Affected
TR1	G01, G02, G09, G10, G17, G18, G25, G26, G33, G34, G41, G42, G49, G50, G57, G58
TR2	G03, G04, G11, G12, G19, G20, G27, G28, G35, G36, G43, G44, G51, G52, G59, G60
TR3	G05, G06, G13, G14, G21, G22, G29, G30, G37, G38, G45, G46, G53, G54, G61, G62
TR4	G07, G08, G15, G16, G23, G24, G31, G32, G39, G40, G47, G48, G55, G56, G63, G64

Table 9-D: TR leads and Associated Rectifiers

Battery Temperature Option

Slope Thermal Compensation and Battery Reserve Time Prediction features of the controller, require that battery temperature be monitored. If either of these features is to be configured in Galaxy software, a battery temperature input must be connected to P3 temperature probe connector on the Controller board.

Three optional cables are used to connect to various battery arrangements:

Cable Assembly	Connects to:
848152997	KS20472 round cell thermistor
848152989	ring or paddle type thermistors
848153003	210E Thermal Probe Multiplexer

Refer to User's Guide for Millennium II Controller Advanced Features manual for additional information on these features.

Alarm Battery Supply Signals

Signal Name	Pin No.
ABS	93
ABS	94
DG	95
DG	96

Table 9-E: ABS Pin Numbers

Fused Battery Supply

BSL-93, 94 ABS: Alarm Battery Supply

This is an alternate plant voltage source for user alarm systems. This power is fused with a 1-1/3 ampere ABS fuse.

BSL-95,96 DG: Discharge Ground

Plant ground/return source for user alarm systems.

Fuses

Two Fuses, located on the MCR1 board, provide protection for the controller input power and Alarm Battery Supply, used to power alarm panels or other devices requiring the power system voltage at no more than 1.3A.

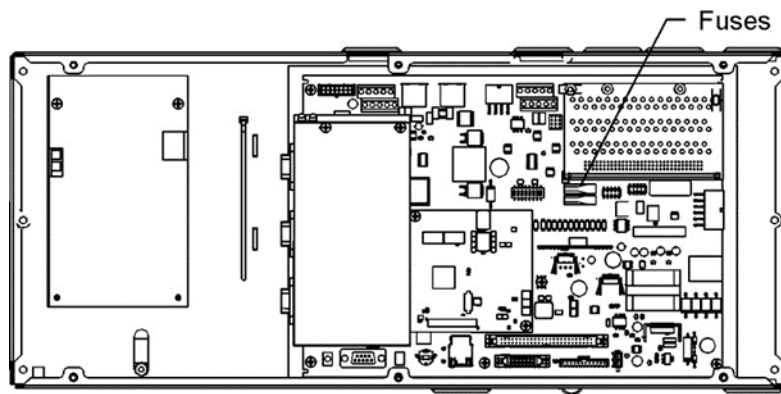

Figure 9-4: Millennium Controller Fuses

FUSE	Description	Fuse Size
F1	Controller Input Power	3A
F2	Alarm Battery Supply (ABS)	1.3A

Front Panel Display

LCD

The primary local interface for the Millennium II is an eight-line LCD assembly mounted to the front of the primary GPS cabinet door. This user interface is a panel that includes a backlit LCD module, two sections of status LEDs, system voltage test jacks, and an array of simple push-button controls. This controller supports multiple LCD display assemblies. It is backwards compatible to both existing Millennium LCD assemblies L51 and L50 shown in Figure 4-5. It is also compatible with the enhanced L52 LCD display assembly (see figure 4-6) specifically developed for the Millennium II. This new display assembly is compatible to existing GPS cabinet doors and is functionally backwards compatible to the Millennium. It looks very similar to the L51 option. LCD assembly, but the L52 also provides a built-in audible alarm and digital contrast adjust that are only available when used with the Millennium II controller.

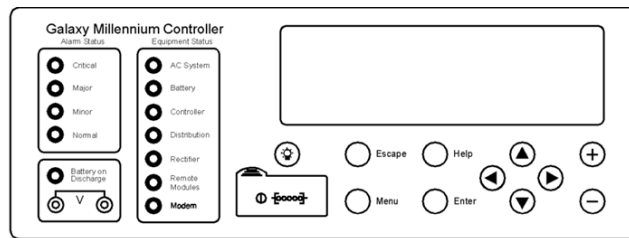

L51

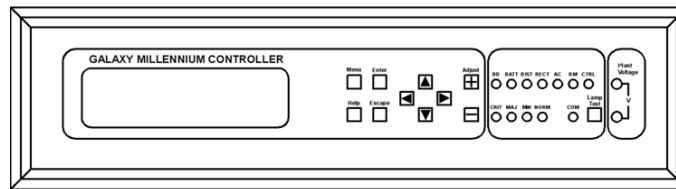

L50

Figure 9-5: Controller Front Panel Displays

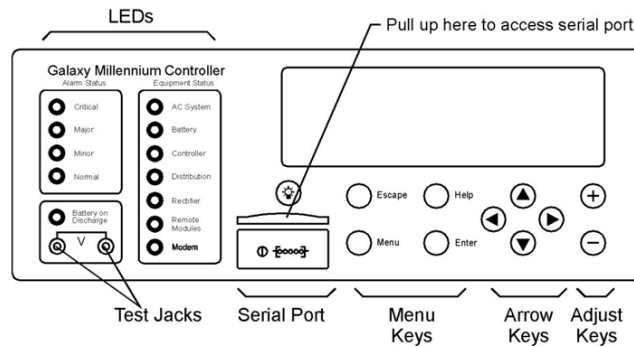

Figure 9-6: Detailed Controller Front Panel Display – L51/52

LEDs

Depending on the LCD option utilized, the LCD assemblies contain two rows of LEDs at the right side of the interface board or two columns of LEDs at the left side of the interface board as seen in figure 4-5. The segregated sections of LEDs provide an indication of the alarm source (rectifier, battery, distribution, communication, controller, remote modules) and the severity (Critical, Major, Minor, Nominal) of the various alarms. Operation of the status LEDs can be reconfigured via the local or remote controller interfaces.

Push Buttons

A group of push-button keys identified in table 4-F, provides the primary method of locally interacting with the Galaxy Millennium II controller. These keys are used singly or in combination to navigate through the menus and follow industry standard functionality. Following is the general description of all the keys.

Key	Function
Up arrow	Use to navigate the menu; press the key to move the cursor up one line.
Down arrow	Use to navigate the menu; press the key to move the cursor down one line.
Left arrow	Use to navigate the menu; press the key to move the cursor left one field.
Right arrow	Use to navigate the menu; press the key to move the cursor right one field.
ADJUST Plus (+)	Use to adjust (increase) the value of a field.
ADJUST Minus(-)	Use to adjust (decrease) the value of a field.
MENU	Press this key any time to bring the MAIN menu online.
HELP	Press this key to display limited on-line help information.
ENTER	Use this key to save a value that has been changed, or to select a menu item.
ESCAPE	Use this key to abort a change, or to go back to the immediate higher level menu.
Lamp Test(L50 Only)	Use this key to test the display and LEDs

Test Jacks

The Millennium II LCD panel assemblies also provide test jacks to provide the ability of using an external meter to monitor the Plant Voltage as seen in figure 4-7. Voltages to the front panel test jacks are current limited and ESD protected. The controller measures this voltage to regulate the system bus voltage as well as display it as the battery plant bus voltage. The value of this voltage is used for many other controller related features.

Serial (PC) Port

A ground referenced RS-232 local port is provided at the front of the display to allow easy connection to a personal computer or terminal using ANSI T1.317 object oriented command language. OmniOn Power's EasyView is also available to provide a user friendly system interface locally or remotely. See figure 4-6.

Alarm Buzzer

The audible alarm buzzer is located on the front panel display assembly. It can be programmed from the front panel display to operate as follows:

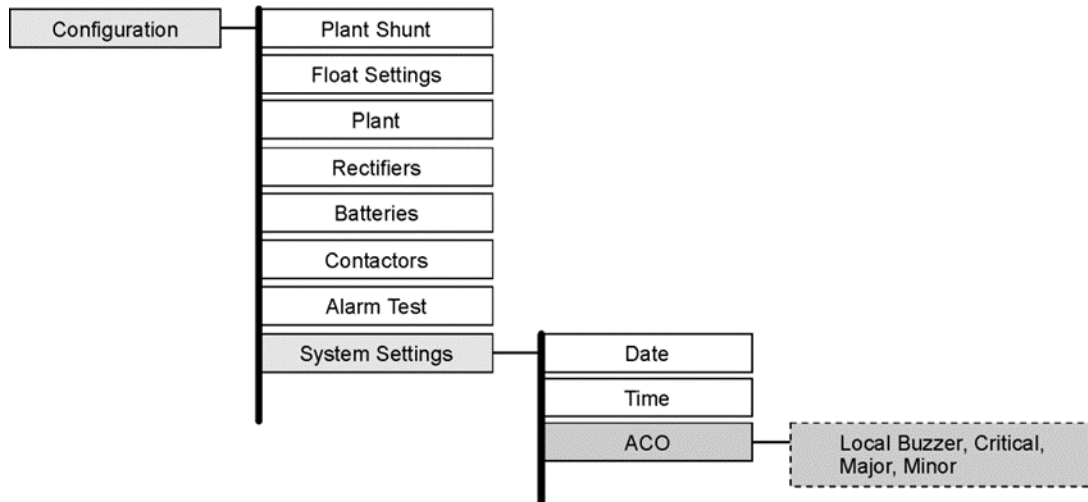

• Disabled for ALL Alarms
• Audible on PCR
• Audible on PMJ
• Audible on PMN

Contrast Adjust

- For L50, L52 Displays:
Press the + or – keys and hold until the display changes it's contrast setting. Once the desired setting is reached, release the button.
- For L51 Displays:
Using a small flat head jeweler's screwdriver, insert it into the small opening at the top of the display assembly (above the UP arrow). Turn clockwise or counter clockwise until the display contrast is set.

Controller Defaults

Dip Switch Settings

The Millennium has 8 dip switch positions (SW202) that may be changed. SW202 is located on the MCR1 board, above the MCR2 board. (See figure 4-7)

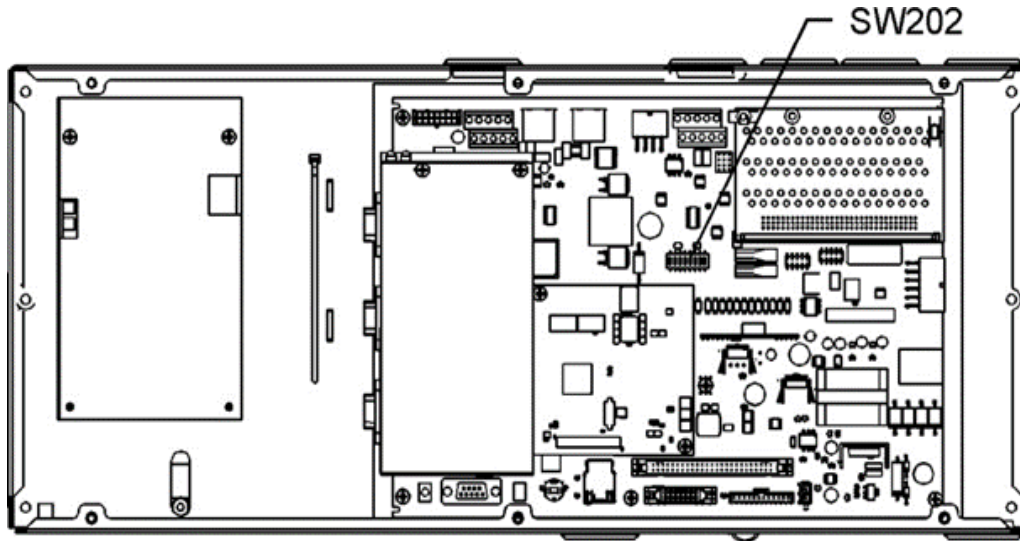

Figure 9-7: Millennium II Controller Dip Switches

Switch Position	Default	Description	Closed (1)	Open (0)
SW202-8	1	Front Panel Configuration	ENABLED	DISABLED
SW202-7	0	Modem/Aux/Local/Gateway/USB/IRDA Port Setting Configuration (Remote Access)	ENABLED	DISABLED
SW202-6	0	Enhanced Security Mode (See table 4-H, for features affected)	ENABLED	DISABLED
SW202-5	1	Auxiliary Port Configuration	RS-232	RS-485
SW202-4	1	Remote Rectifier in Standby	ENABLED	DISABLED
SW202-3	0	Boost Mode	ENABLED	DISABLED
SW202-2	1	Reserved for Future Use	ENABLED	DISABLED
SW202-1	1	Reserved for Future Use	ENABLED	DISABLED

Table 9-G: Millennium II Controller Dip Switch Settings

<p>The modem and auxiliary ports can be configured for full access and read-only using DIP switch 202-7. Restricted access is also available. This prevents changes in the modem and auxiliary ports that will affect the state of the plant, even when logged in as a Super-User or Administrator. This enhanced remote security is enabled and disabled with DIP switch SW202-6. The functions and parameters restricted with the enhanced remote security feature are listed in this table.</p>
Enable or disable Rectifier Restart feature
Change All Rectifier On Threshold
Change Timed Manual Boost Duration
Change Boost Current Threshold
Change Rectifier Status to “Standby”/ “Vacant” status is prohibited. The change to “On” status is allowed.
Change Rectifier Shunt Voltage configuration
Change Rectifier Float High Voltage Shutdown Threshold
Change Rectifier Boost High Voltage Shutdown Threshold
Change Rectifier Float Set Point
Change Rectifier Boost Set Point
Change Rectifier Boost Current Limit
Change Converter Voltage Set-Point
Change Converter Low Voltage Disconnect Threshold
Change Converter Low Voltage Reconnect Threshold
Enable or disable Converter Low Voltage Disconnect feature
Change Converter Status to “Standby”/ “Vacant” status is prohibited. The change to “On” status is allowed.
Change Battery High Temperature Threshold
Enable or disable Battery Current Limit
Change Battery Limit Threshold
Change Battery Contactor Status to “Open” status is prohibited. The change to “Close” status is allowed.
Change Battery Disconnect Threshold
Change Battery Reconnect Threshold
Change Very Low Voltage Alarm Threshold and Severity
Change Multiple Rectifier Fail Alarm Threshold and Severity
Change Limited Recharge Current Alarm Threshold and Severity
Change Excess Rectifier Drain Alarm Threshold and Severity
Change Engine Transfer Timeout Alarm Threshold and Severity
Change Reserve Time Low Alarm Threshold and Severity
Change Multiple Converter Fail Alarm Threshold and Severity
Change Battery On Discharge Alarm Threshold and Severity

Voltage Threshold Ranges and Default Values

	Low	High	Default
Very Low Voltage (VLV)			
24V	20.00	25.50	23.00
48V	40.00	51.00	46.00
Battery on Discharge (BD)			
24V Float	23.00	28.00	25.00
24V Boost	23.00	28.00	25.00
48V Float	46.00	55.00	51.00
48V Boost	46.00	55.00	51.00
High Float Voltage (HFV)			
24V Float	24.75	29.75	26.50
24V Boost	25.75	31.75	26.50
48V Float	50.00	60.00	53.00
48V Boost	52.00	60.00	53.00
High Voltage Shutdown Alarm (HV)			
24V Float	24.75	29.75	26.8
24V Boost	25.75	31.75	26.8
48V Float	50.00	60.00	53.6
48V Boost	52.00	60.00	53.6
Rectifier On Threshold (ROT)			
24V	20.00	25.00	22.00
48V	40.00	51.00	44.00

Table 9-I: Voltage Threshold Ranges and Default Values

Controller Alarm Severity, LED and Relay Default Values

Symbol	Default Designation	Default Severity	Default LED	Default Relay
AAC	ACO Active	RO	None	None
ABS	Alarm Battery Supply Fuse	Major	CTLR	CTLR
AMJ	Auxiliary Major	Major	None	None
AMN	Auxiliary Minor	Minor	None	None
ATA	Alarm Test Active	RO	None	None
ATB	Alarm Test Aborted	RO	None	None
ATF	Alarm Test Failed	Warning	None	None
BBL	Memory Backup Battery Low	Warning	None	None
BCA	Battery Type Conflict	Warning	None	None

Table 9-J: Controller Alarm Severity, LED and Relay Default Values

Controller Alarm Severity, LED and Relay Default Values (continued)

Symbol	Default Designation	Default Severity	Default LED	Default Relay
BDA	Battery on Discharge	Major	BD	BD
BFA	Battery Test Failed	Minor	BAT	None
BID	Bay Interface ID Conflict	Major	CTRL	CTRL
BTA	Battery Test Active	RO	BD	BD
BTJ	Battery Thermal Major	Major	BAT	None
BTN	Battery Thermal Minor	Minor	BAT	None
CCH	Configuration Changed	RO	None	None
CDFA	Converter Distribution Fuse	Major	RECT	MJF
CDID	Converter ID Conflict	Major	RECT	None
CFA	Converter Fail	Minor	RECT	None
CLC	Clock Changed	RO	None	None
CMA	Minor Communications Failure	Minor	CTRL	None
CMFA	Multiple Converter Fail	Major	RECT	None
CNF1	Contactors 1 Failed	Major	BAT	None
CNF2	Contactors 2 Failed	Major	BAT	None
CNF3	Contactors 3 Failed	Major	BAT	None
CNO1	Contactors 1 Open	Major	BAT	None
CNO2	Contactors 2 Open	Major	BAT	None
CNO3	Contactors 3 Open	Major	BAT	None
COF	Queue Overflow	Warning	None	None
COR	Number Did Not Respond	Warning	None	None
CPA	Circuit Pack Fail	Major	CTRL	CTRL
CRA	Controller Fail	Major	CTRL	CTRL
DID	Rectifier ID Conflict	Major	RECT	None
EMD	Energy Management Disabled	Warning	None	None
EPD	Excess Plant Drain	Minor	RECT	None
EPO	Emergency Power Off	Critical	BATT	None
EPR	External Password Reset	Warning	None	None
ETO	Engine Transfer Timeout	Minor	AC	None
EXL	Excessive Login Attempts	Warning	None	None
FAJ	External Fuse Major	Major	DIST	MJF
FAN	External Fuse Minor	Minor	DIST	MNF
HCL	History Cleared	RO	None	None

Table 9-J: Controller Alarm Severity, LED and Relay Default Values

Controller Alarm Severity, LED and Relay Default Values (continued)

Symbol	Default Designation	Default Severity	Default LED	Default Relay
HFV	High Float Voltage	Minor	RECT	None
HVA	High Voltage	Major	RECT	HV
LMR	Limited Recharge	Minor	RECT	None
LVD	Low Voltage Disconnect	Minor	BAT	None
LVDA	Low Voltage Disconnect Fail	Minor	BAT	None
MCM	Major Communication Fail	Minor	CTLR	None
MDF	Module Failure	Minor	RM	None
MOR	Measurement Out Of Range	Minor	RM	None
MTC	Module Type Conflict	Warning	None	None
NNC	Number Not Configured	Warning	None	None
OSA	Open String	Minor	BAT	None
PFD	Password At Default	Warning	None	None
PGI	Program Line Invalid	Major	None	None
PHT	Processor Halt	RO	None	None
POR	Number Did Not Respond	Warning	None	None
RLS1	Redundancy Loss	Minor	RECT	None
RPI	Rectifier/Plant Inconsistency	Warning	None	None
RTL	Reserve Time Low	Minor	BAT	None
SNC	Shunt Not Configured	Warning	None	None
STF	Self Test Failed	Minor	CTLR	CTLR
TPA	Thermal Probe Failure	Minor	CTLR	CTLR
URC	User Relay Conflict	Warning	None	None
VLA	Very Low Voltage	Critical	BAT	UR3
VSF	Sense/Control Fuse	Major	CTLR	CTLR
ZID	ID Not Configured	Major	RECT	None

Table 9-J: Controller Alarm Severity, LED and Relay Default Values

Symbol	Default Designation	Default Severity	Default LED	Default Relay
ACF	AC Fail	Minor	AC	ACF
CLM	Rectifier Current Limit	RO	None	None
ERD	Excess Rectifier Drain	Minor	RECT	None
ETS	External Transfer Shutdown	Minor	RECT	None
HPA	Half Power	Minor	RECT	None
LCA	Low Current Alarm	Minor	RECT	None
LSF	Load Share Fuse	Minor	RECT	None
MACF	Multiple AC Fail	Major	AC	ACF
MAN	Manual Off	Minor	RECT	None
MFA	Multiple Rectifier Fail	Major	RECT	RFA
MMAN	Multiple MAN Alarm	Major	RECT	None
PHA	Phase Or Low Output	Minor	AC	None
RIC	Rectifier Incomplete Config	Warning	None	None
RFA	Rectifier Fail	Minor	RECT	RFA

Table 9-J: Controller Alarm Severity, LED and Relay Default Values

Default Display

The default display shown in figure 4-8 provides basic system status. The controller returns to this display after approximately three minutes after the last time a key is pressed.

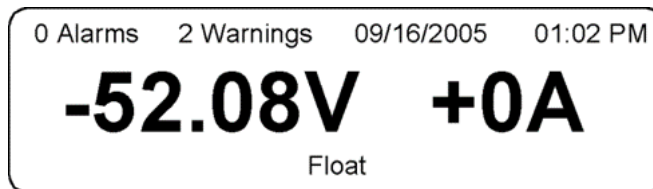

Figure 9-8: Millennium II Controller Default Display

The first line shows:

# of Alarms	# of Warnings	Date	Time
-------------	---------------	------	------

The larger text in the middle of the screen shows:

Plant Voltage	Plant Load (Current)
---------------	----------------------

The bottom line(s) show:

<p>An Hourglass may appear in the lower left hand corner of the screen. This indicates that a configuration change is being saved to non-volatile memory.</p>
<p>Audible Alarm Cutoff State(Toggle) (Only shown if an alarm is active)</p>
<p>Plant Mode (Default Float)</p>

Screen information is updated approximately every two seconds. The front panel display offers a series of menus that allow the user to:

- Configure
- Control
- View Status
- View History
- View Statistics
- Perform Diagnostics

These menu operations are accomplished by navigating through different screens.

Controller Display Menu Maps

Configuration Menu Map

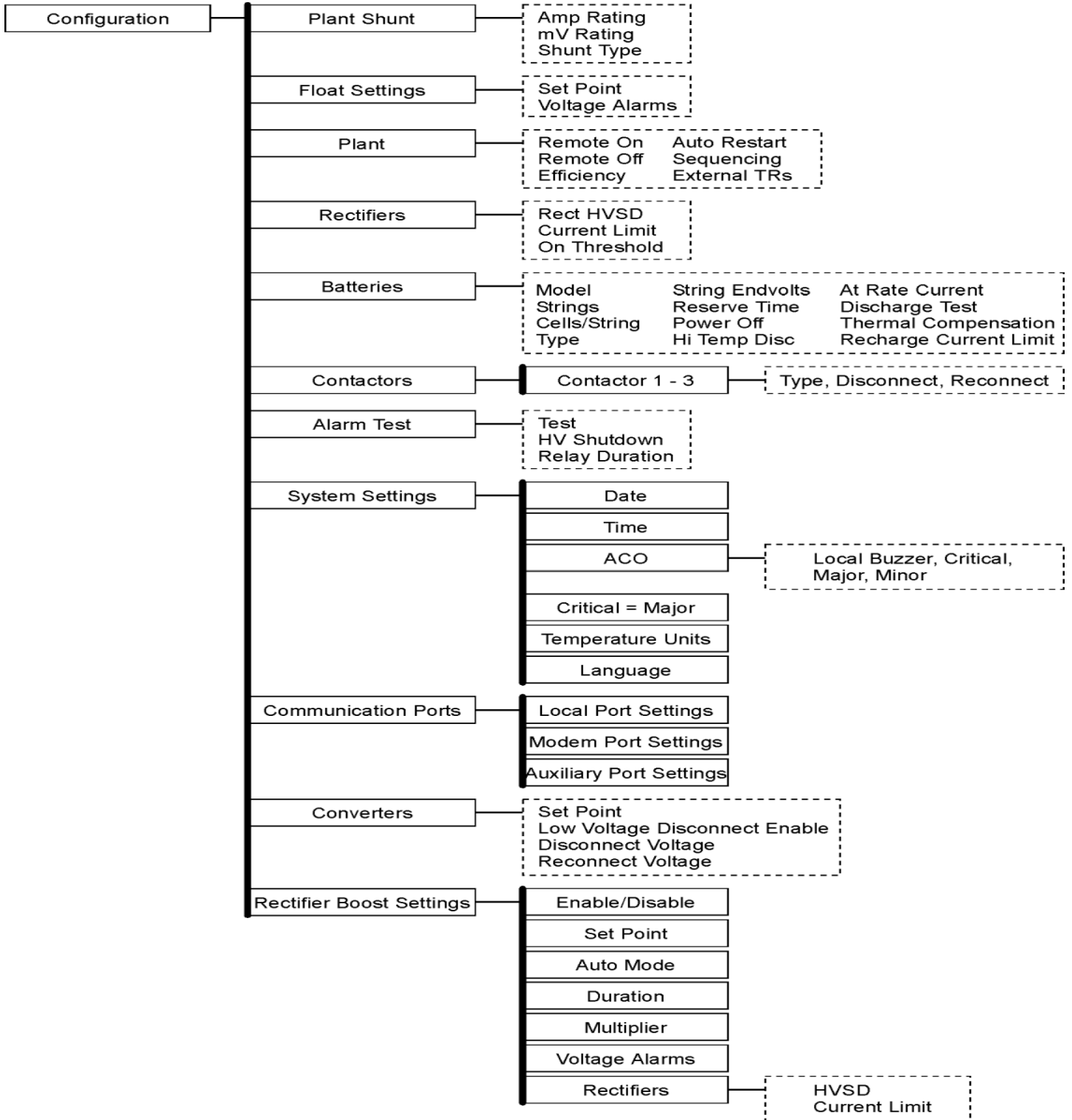

Control and Operations Menu Map

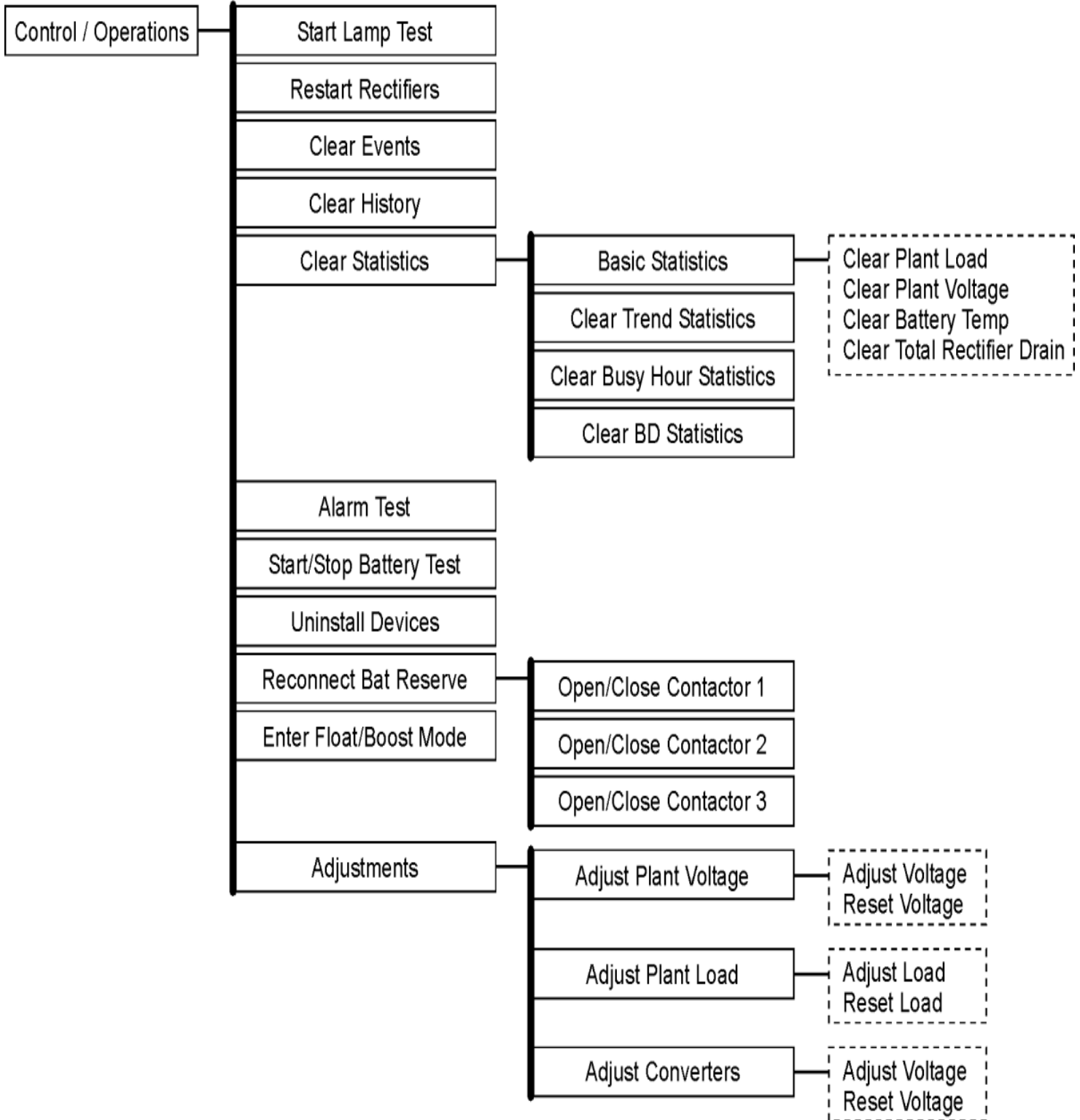

Status Menu Map

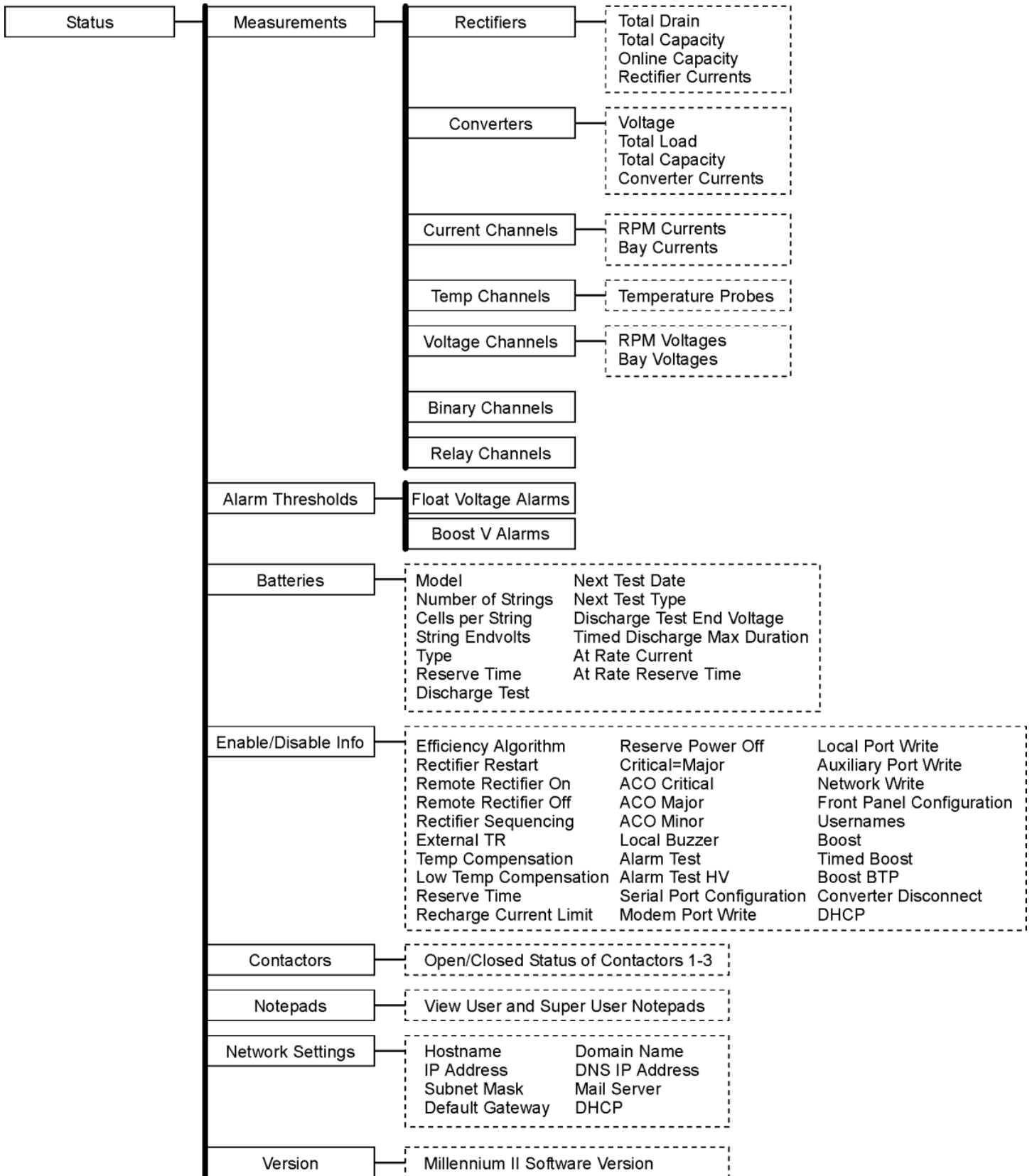

History Menu Map

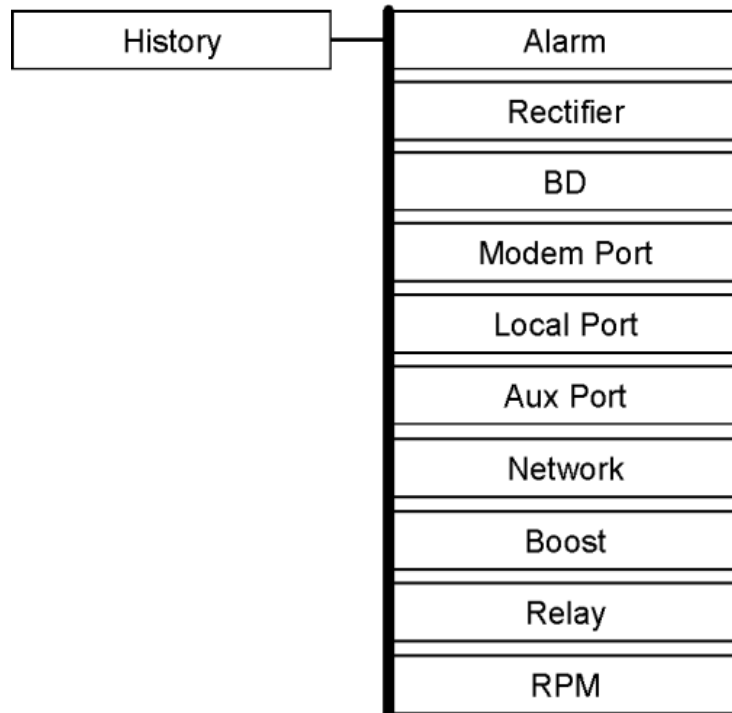

Statistics Menu Map

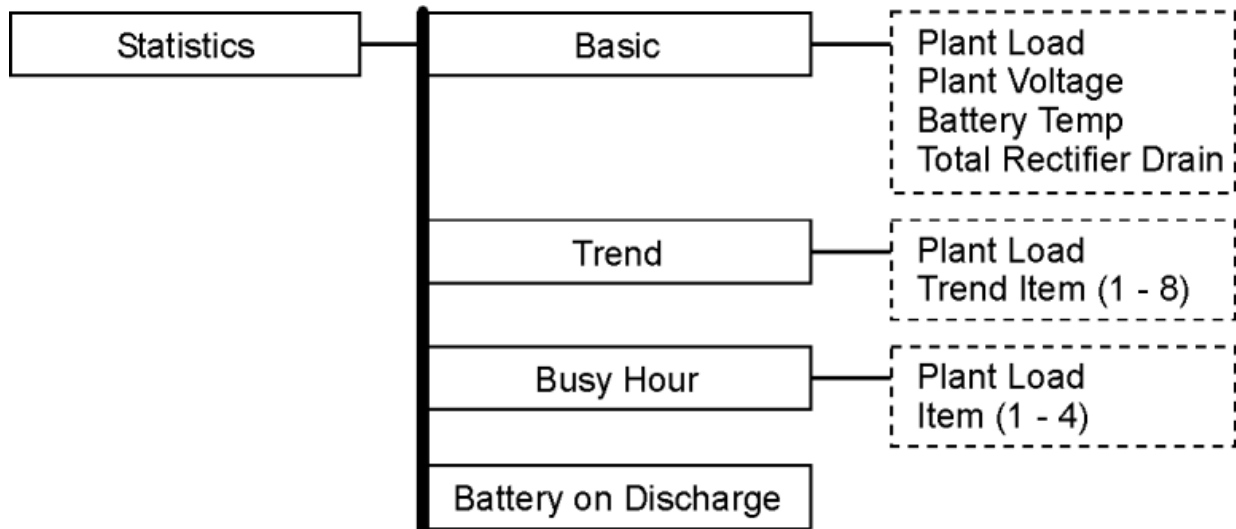

Minimum Configuration

Front Panel

The Millennium II controller’s primary user interface is the front panel, which includes a backlit LCD, and an array of pushbutton controls. SW202-8 must be set to ENABLED for changes to be made from the front panel. This section covers only the basic operations that must be performed so that the controller is minimally configured. For more advanced operations, please see the User’s Guide for Millennium II Controller – Advanced Features.

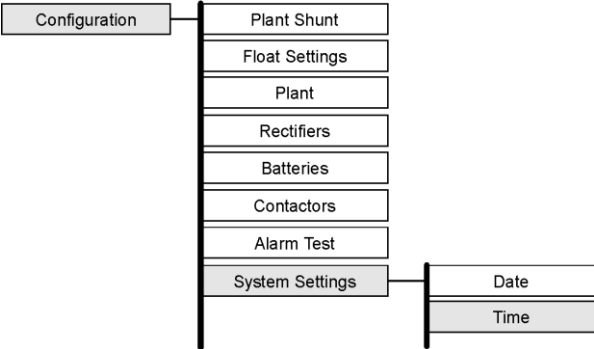
Step	Configuration Attribute to Change	Menu Path/Action	Customer Value
1.	DATE/TIME		
	Format	This field allows you to select one of the following date formats: MM/DD/YY, DD/MM/YY, YY/MM/DD, MM/DD/YYYY, DD/MM/YYYY, YYYY/MM/DD. Use the <+> or <-> key to select the desired format and press <ENTER> to save the change.	
	Month	Use this field to change the month; the possible value is from 1 to 12.	
	Day	Use this field to change the day of the month; the possible value is from 1 to 31.	
	Year	Use this field to change the year; the possible value is from 1992 and up.	
NOTE:		Please note that the system will validate the entries before the system date is modified.	
2.	TIME		
	Format	This field allows you to select one of the following time display formats: 12 or 24 hour. Use the <+> or <-> key to select the desired format and press <ENTER> to save the change.	
	Time	Allows you to change/set the time.	
	Daylight	Enables or Disables Daylight Savings.	

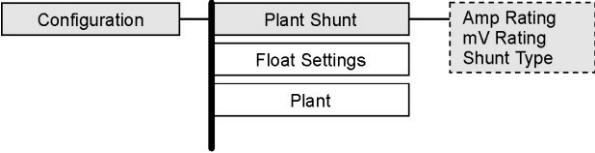
3.	SYSTEM SHUNT		
	Type	<p>This selection allows the operator to configure the type of shunt that is connected to the controller. Possible values are LOAD, BATTERY, or NONE. The configuration is determined by the plant architecture. Refer to the GPS Power Plant Product Manual for a description of these architectures.</p> <p>In a plant using distributed architecture a shunt type of NONE should be selected. In this arrangement, up to 32 shunts, located between batteries and plant bus bars, can be connected to the Bay Interface Cards in the system bays. The controller reads the shunt currents over the serial data connection. The load current displayed is derived from the total of battery currents and the total of rectifier currents.</p> <p>In a plant using centralized architecture, either LOAD or BATTERY should be selected. A maximum of two shunts of the same amperage can be connected through P6 on the BSH. A shunt type of LOAD means that a load shunt, located between load and plant bus bars, is connected. The load current displayed on the front panel is the sum of the two shunt currents. A shunt type of BATTERY means that a battery shunt located between the batteries and plant bus bars is connected. The load current displayed on the front panel</p> <p>is derived from the total battery current and the total rectifier output current.</p> <p>Use the <+> or <-> key to change the field values. Press <ENTER> to save the changes.</p>	
	mV	<p>The first item to configure is the Plant Voltage shunt. Make sure the cursor is on the SHUNT mV field and use the <+> or <-> key to step through the available values (25, 50, 60, 100, 150 mV). Select the one that best suits the application; press the <ENTER> key to save the change.</p>	
	I	<p>Move the cursor to the SHUNT I field by using the <UP>/<DOWN>/<LEFT>/<RIGHT> ARROW keys. Use the <+> or <-> key to step through the available values (0-99999). Select the desired value; press <ENTER> to save the change.</p>	

4.	ALARM THRESHOLDS		
	High Voltage	<p>When the plant voltage exceeds this threshold, the plant High Voltage Alarm (HVA) is turned ON, and the controller will send a signal to the rectifiers to shut down in an orderly and timely fashion. This will also light the Major (MJ) LED, and activate the PMJ relay (assuming there is no alarm with CRITICAL severity level active). Move the cursor to the fields and use the <+> or <-> key to adjust the High Voltage shut down alarm for FLOAT mode to the desired level. Press <ENTER> to save the change.</p>	
	High Voltage Float	<p>When the plant voltage exceeds this threshold, the plant High Float Voltage Alarm (HFV) is turned ON, and this will also light the Minor LED, activate the PMN contact closure (assuming there is no alarm with CRITICAL or MAJOR severity level active). The purpose of this alarm is to indicate that the plant voltage is high probably due to an adjustment in the plant rather than due to a failure. This alarm allows the High Voltage (HV) shutdown threshold to be raised slightly, thus reducing the number of nuisance shutdowns without decreasing the plant reliability. Move the cursor to the fields and use the <+> or <-> key to adjust the High Voltage shut down alarm for FLOAT mode to the desired level (normally less than the HV threshold). Press <ENTER> to save the change.</p>	
	Battery on Discharge	<p>If the plant voltage is less than the threshold value, the Battery Discharge alarm is turned ON, this in turn activates the PMJ and BD relay, light the MAJ and BD LEDs. Move the cursor to the fields, and use the <+> or <-> key to adjust the threshold to the desired level. Press <ENTER> to save the change.</p>	
	Very Low Voltage	<p>This alarm threshold is used to indicate that the system voltage is very low, and that the batteries have discharged to a dangerously low depth. When the plant voltage falls below this level, the Very Low Voltage (VLV) and Power Critical alarm will be generated. Move the cursor to the field and use the <+> or <-> key to adjust the threshold value. Press <ENTER> to save the change.</p>	

5.	Rectifiers		
	Setpoint	<p>This value sets the system voltage for all serial rectifiers. Move the cursor to the field and use the <+> or <-> key to adjust the threshold value. Press <ENTER> to save the change.</p>	
	HVSD		
	HVSD	<p>The configuration of this field sets the internal high voltage shutdown value of all serial rectifiers. Move the cursor to the field and use the <+> or <-> key to adjust the threshold value. Press <ENTER> to save the change.</p>	
6.	Batteries		
	Model	<p>The configuration of this field selects the installed battery type from a list of pre- defined battery types used in reserve time prediction and enhanced battery test features. Move the cursor to the field and use the <+> or <-> key to adjust the threshold value. Press <ENTER> to save the change.</p>	
	Strings	<p>The configuration of this field selects the number of battery strings in the system. This parameter is used in reserve time prediction and enhanced battery test features. Move the cursor to the field and use the <+> or <-> key to adjust the threshold value. Press <ENTER> to save the change.</p>	
	Cells/String	<p>The configuration of this field selects the number of installed cells in the battery strings. This parameter is used in reserve time prediction and enhanced battery test features. Move the cursor to the field and use the <+> or <-> key to adjust the threshold value. Press <ENTER> to save the change.</p>	

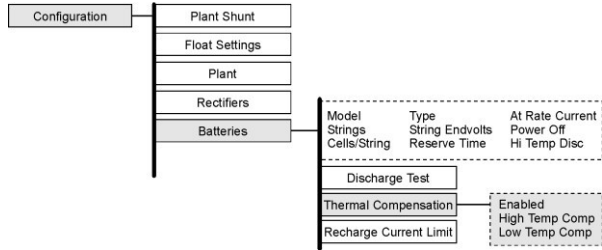
	Type	The configuration of this field selects the batter type, Flooded or Valve Regulated(sealed). This parameter is used in reservetime prediction and enhanced battery test features. Move the cursor to the field and use the <+> or <-> key to adjust the threshold value. Press <ENTER> to save the change.	
7.	Thermal Comp	 <p>This feature allows dynamic control of sealed cell battery voltage as a function of temperature.</p>	
	Enabled	Enables or Disables the Thermal Compensation Feature. Move the cursor to the field and use the <+> or <-> key to Enable or Disable. Press <ENTER> to save the change.	
	High Temp Comp	This feature allows the system to compensate for high temperatures.	
	Volt StepDown	Battery step temperature can be set from 113-185F. At this temperature, the system voltage is reduced by 0.17 X # of cells/string.	
	High Comp Limit	This sets the maximum temperature for which thermal compensation is active.	
	Decrease	This sets the slope (mV/degC) for high temperature compensation.	
	NominalTemp	This field set the temperature at which no compensation is required. The system voltage is at the setpoint float mode.	
	Low Temp Comp	This feature allows the system to compensate for low temperatures.	
	Low T Comp	This enables or disables the low temperature compensation feature.	
	Low Comp Limit	This sets the minimum temperature for which thermal compensation is active.	
	Increase	This sets the slope (mV/degC) for low temperature compensation.	

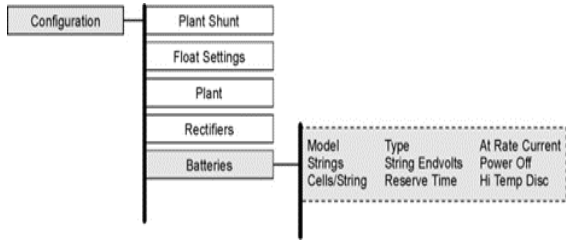
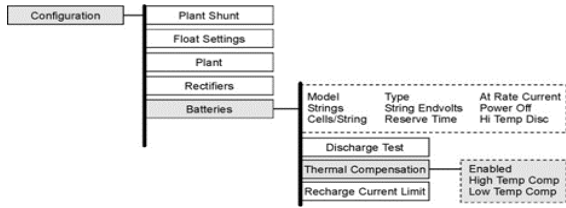
8.	Recharge Current Limit	<p>This feature sets the total amount of current that will be allowed to recharge the batteries.</p> 	
	Limit	The configuration of this field enables or disables the feature.	
	Limit to	This programmable value sets the maximum amount of recharge current (in Amps) that will be allowed for recharging the batteries. The range is from 10 – 1000A.	
9.	Contactors	<p>Up to three optional LVD devices can be connected to a Millennium and configured from this screen.</p> 	
	Contactor 1-3		
	Type	<p>This setting identifies the type of contactor, BATTERY, LOAD or NONE that has been installed in the plant. Be sure that the wiring for the contactor being configured matches the type chosen here. For standard GPS configurations using BIC cards, Contactor 1 is wired to and controls all BATTERY contactors in the plant. Contactors 2 and 3 are wired to and control only LOAD contactors. To toggle between the various contactor types, move the cursor to one of the fields and use the <+> or <-> key to select the desired type. Press <ENTER> to save the change.</p>	
	Disconnect	<p>This setting configures the plant voltage at which the contactor will disconnect from the bus. Use the <+> or <-> key to adjust the voltage to the desired level. Press <ENTER> to save the change.</p>	
	Reconnect	<p>This setting configures the plant voltage at which the contactor will reconnect to the bus. To prevent the contactor from re-operating when battery voltage increases due to load removal, a voltage several volts higher than the disconnect voltage is recommended. Use the <+> or <-> key to adjust the voltage to the desired level. Press <ENTER> to save the change.</p>	

10. Acceptance Testing

Introduction

The Galaxy Millennium Controller is tested before it leaves the factory, but many users wish to add some test procedures as part of installation and turn-up. The tests described here will simulate various alarm conditions and verify that the controller functions properly. Follow the steps listed below in the order they are given.

Tools and Test Equipment

Tools and Test Equipment Required for Acceptance Testing
Digital Voltmeter (DVM) with dc accuracy of at least 0.05%
Short length of wire or clip lead for jumper
Jeweler's screwdriver

Test Precautions

Follow these steps to test plant alarms when installing the Galaxy Millennium Controller in a new plant. In a new installation, begin the sequence with the rectifiers running with a dummy load on the plant bus bar.
For these tests, it is assumed that:
<ul style="list-style-type: none"> • All rectifiers are functioning properly.
<ul style="list-style-type: none"> • Plant batteries have received their original charges and are ready to support a load.
If you are testing a controller in a live plant:
<ul style="list-style-type: none"> • Some tests will cause a battery discharge. Insure that plant batteries are capable of supporting the load.
<ul style="list-style-type: none"> • Alarms will be generated. Notify the appropriate alarm monitoring personnel.

Test Sequences

Lamp Test

This test verifies that All of the LEDs on the front panel of the controller are functioning properly. **No alarms are generated from this test.**

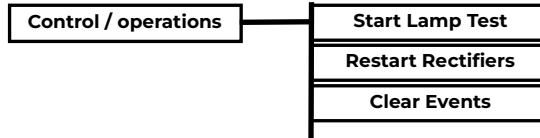

Step	Action
1.	From the Default Screen, press the Menu button for the Main Menu.
2.	Using the Up/Down Arrows, Scroll to Control/Operations and press Enter .
3.	Select Start Lamp Test , and press Enter .
4.	Press Enter again to start the test, or Escape to return to the menus.
5.	Observations: <ul style="list-style-type: none"> • LCD Refreshes • Front Panel LEDs ALL turn on momentarily and return to normal • NO alarms are generated from this test

Front Panel Display Meter Calibration

Using a calibrated digital voltmeter, measure the plant voltage from the front panel test jacks.

Follow these steps to calibrate the front panel meter display for Voltage and Current readings:

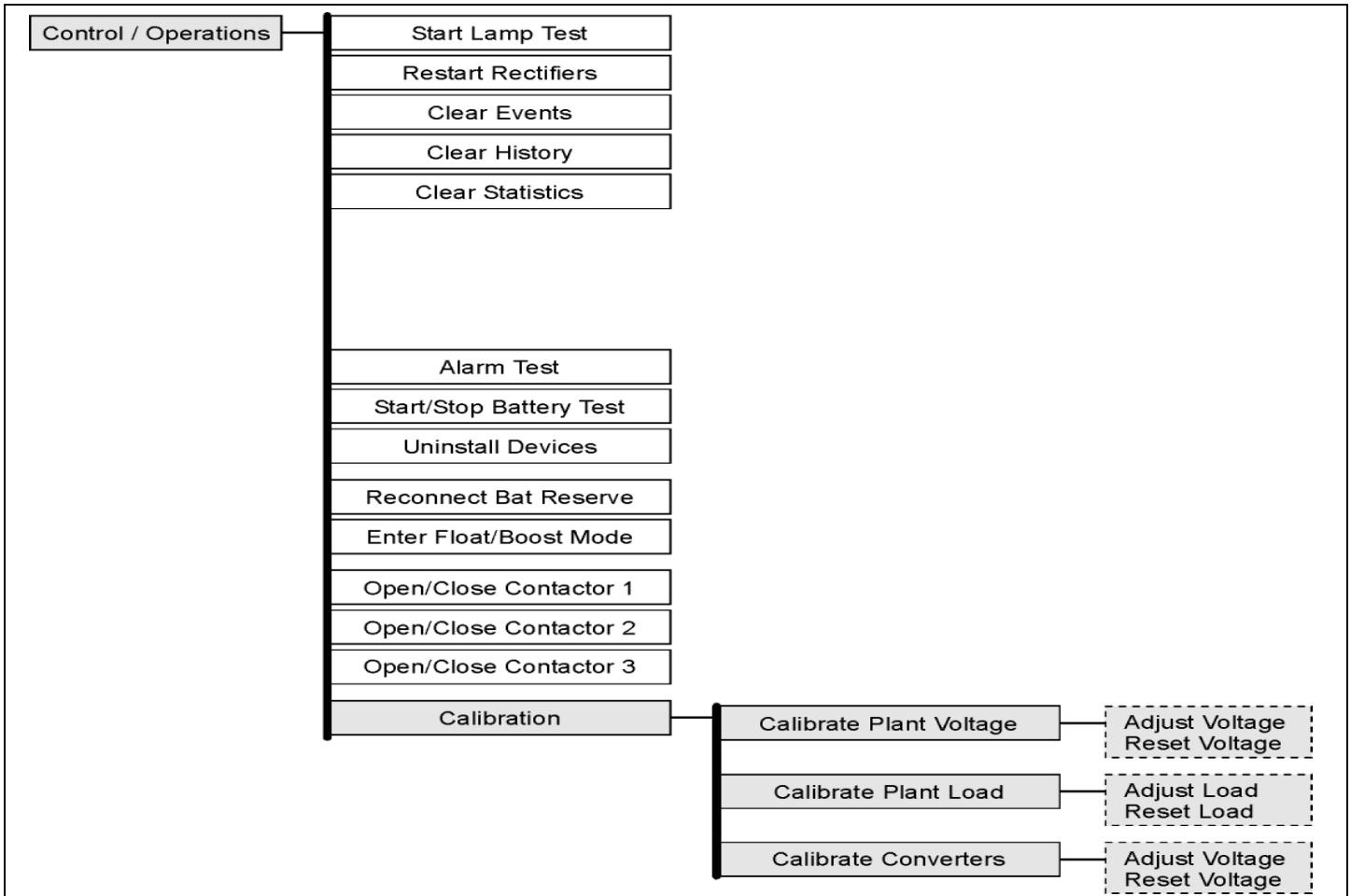

Step	Action for Voltage Calibration
1.	Using the Meter Calibration Menus, reset the plant voltage reading by selecting RESET VOLTAGE. Press the Enter key to reset the voltage. This will remove any pre-existing user calibrated values if they exist.
2.	Wait at least 5 seconds and press the ESCAPE key.
3.	Select CALIBRATE VOLTAGE. Use the Arrows, and UP/DOWN keys to calibrate the system voltage. Press ENTER to save.
NOTE:	The controller will not allow changes greater than +/- 0.5V of the displayed voltage.
4.	Press the <ESCAPE> key until the default screen is displayed. Verify that the plant voltage reading now agrees with the calibrated DVM.
NOTE:	The DVM reading will be the one to change since Rectifier Manager will adjust rectifier outputs as necessary per the calibration performed.

Step	Action for Current Calibration
NOTE:	The following procedure is applicable only in plants with Load shunts

Step	Action for Current Calibration
NOTE:	The following procedure is applicable only in plants with Load shunts in a plant configured for "Centralized Architecture."
1.	Using a calibrated DVM, measure the plant load from the sense connection points on the plant shunt(s).
2.	Calculate the plant load, in amperes, as measured by the DVM. a. Divide the mV DVM reading by the rated shunt mV value b. Multiply this result by the shunt ampere rating This value is the plant load measured by the DVM, in amperes.
3.	Using the Meter Calibration Menus, reset the plant Plant Current reading by selecting RESET LOAD. Press the Enter key to reset the load. This will remove any pre-existing user calibrated values if they exist.
4.	Wait at least 5 seconds and press the ESCAPE key.
5.	Select CALIBRATE LOAD. Use the Arrows, and UP/DOWN keys to calibrate the system Load. Press ENTER to save.
NOTE:	The maximum total change is +/-10% of the current load value .
6.	Press the <ESCAPE> key until the default screen is displayed. Verify that the plant current reading has been changed.
NOTE:	This operation is performed and verified ONLY if plant load is constant during the calibration procedure.
	Observation: <ul style="list-style-type: none"> • Displayed System load changes to new value.

High Float Voltage Alarm – New Installations only

Step	Action for Testing the High Float Voltage Alarm
NOTE:	Clear all controller alarms for this test.
NOTE:	The high voltage alarm test is completed by raising the plant voltage above the threshold set for HFV (High Float Voltage) .
NOTE:	Raising the plant voltage on a working system is left to the discretion of the user. <ul style="list-style-type: none"> • This test could disrupt power to working equipment. • If the test is performed, verify that the plant is in FLOAT mode • Rectifier voltage has been set to the normal level after completing the test.
1.	Using the Voltage Alarms Menu Screens, note High Float Alarm threshold value. ____
2.	Using the Float Settings Menu Screens, select Set Point and note the value. _____
NOTE:	The next step WILL RAISE the system voltage.
3.	Use the Arrows, and UP/DOWN keys to change the system float voltage setpoint to 0.1V above the High Float Alarm Threshold.. Press ENTER to save.

4.	<p>Observe:</p> <ul style="list-style-type: none"> The plant voltage increases to the set voltage Power Minor alarm (PMN) is generated RECT and MIN LEDs are illuminated
5.	Using the Float Settings Menu Screens, select Set Point.
6.	Use the Arrows, and UP/DOWN keys to change the system float voltage setpoint to it's original value. Press ENTER to save.
7.	<p>Observe:</p> <ul style="list-style-type: none"> The plant voltage decreases to the original set voltage Power Minor alarm (PMN) retires RECT and MIN LEDs are extinguished

High Float Voltage Alarm – Systems with Actual Loads

Step	Action for Testing the High Float Voltage Alarm
NOTE	Clear all controller alarms for this test.
NOTE	The System Voltage WILL NOT change.
NOTE	The high float voltage alarm test is completed by changing the threshold for this condition below the system voltage to make it active.
1.	Using the Float Settings Menu Screens, select Set Point and note the value.. _____
2.	Using the Voltage Alarms Menu Screens, note the High Float Alarm threshold value.. _____
3.	Use the Arrows, and UP/DOWN keys to change the High Float Alarm Threshold to 0.1V below the System Voltage. Press ENTER to save.
4.	<p>Observe:</p> <ul style="list-style-type: none"> Power Minor alarm (PMN) is generated RECT and MIN LEDs are illuminated
5.	Using the Voltage Alarms Menu Screens, change the High Float Alarm threshold value to it's original value. Press ENTER to save.
6.	<p>Observe:</p> <ul style="list-style-type: none"> Power Minor alarm (PMN) retires RECT and MIN LEDs are extinguished

High Voltage Shutdown – New Installations Only

STEP	Action for Testing High Voltage Shutdown Alarm
NOTE:	The High Voltage Shutdown Test is recommended only for new installations where a dummy load is available prior to the application of office load, and batteries are connected.
NOTE:	There are three requirements for a serial rectifier to shut down upon a controller initiated High Voltage Alarm.

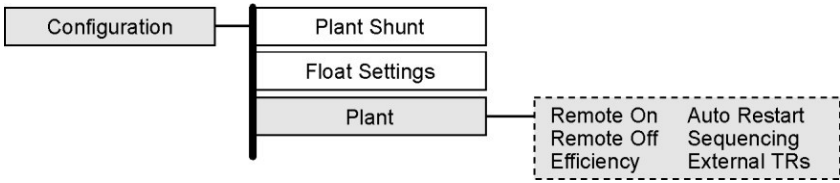
	<ol style="list-style-type: none"> The plant voltage must be above the level set for the High Voltage alarm at the VOLTAGE ALARMS menu screen: MENUà CONFIGUREàFLOAT SETTINGSàVOLTAGE ALARMS The rectifier must be delivering a current of at least 10% of its capacity. The rectifier's current output must be unbalanced by more than 10% from the average output currents of the other rectifiers. <p>Because item 3 is difficult to achieve in a simulation test of properly functioning serial rectifiers, (even with load share disabled), rectifiers are tested one at a time, rather than as a group. Slightly different test procedures are used for special applications in batteryless plants. Serial rectifiers have their own internal restart circuits which will function 3 times before the rectifier locks itself out and initiates a High Output Rectifier Fail Alarm to the controller. If there is a sufficient interval between restart and a subsequent shutdown the rectifier resets its restart counter. The controller initiates a restart signal a few seconds after the first RFA (HO) alarm is received. After the second RFA (HO) is received, the controller waits 5 minutes before sending one additional restart signal.</p>
1.	<p>Verify the Auto Restart is enabled from the front panel menus:</p>  <pre> graph LR Config[Configuration] --- Plant[Plant] Plant --- Shunt[Plant Shunt] Plant --- Float[Float Settings] Plant --- Menu[Remote On, Remote Off, Efficiency, Auto Restart Sequencing, External TRs] </pre>
2.	Turn off all rectifiers except the rectifier under test by operating their power switches to STBY.
3.	Adjust the dummy load to provide 10 to 30% of the rectifier's output capacity.
4.	Using the Voltage Alarms Menu Screens, note High Voltage Alarm threshold value. _____
5.	Using the Float Settings Menu Screens, select Set Point and note the value. _____
NOTE:	The next step WILL RAISE the system voltage.
6.	Use the Arrows, and UP/DOWN keys to change the system float voltage setpoint to 0.1V above the High Voltage Alarm Threshold.. Press ENTER to save.
7.	<p>Controller Observations:</p> <ul style="list-style-type: none"> The plant voltage increases Power Major alarm (PMJ) is generated

	<p style="text-align: center;">RECT and MAJ LEDs are illuminated</p> <p>Rectifier Observations:</p> <ul style="list-style-type: none"> • When the voltage increases to the HV (FLOAT) level the rectifier shuts down. • The Green ON LED on the rectifier blinks, the ALM LED on the rectifier is not lit. • After 5-6 seconds the rectifier initiates its own restart signal again raising the plant voltage. • The rectifier will shutdown and restart two additional times. • Upon the third shutdown, the rectifier's ALM LED lights and the rectifier's display indicates "HO". • The controller receives the RFA signal from the rectifier and initiates a restart signal 5-6 seconds later. • The rectifier restarts again raising plant voltage. • The rectifier shuts down and restarts 3 additional times. During these shutdowns the Green ON LED on the rectifier blinks and the ALM LED on the rectifier is not lit. • Upon the fourth shutdown, the rectifier's ALM LED lights and the rectifier's display indicates "HO". • Any external RFA office alarm has occurred. • The controller will wait 5-6 minutes and issue one final restart signal initiating the final sequence of shutdown and restart events before the rectifier locks out, requiring personnel intervention. <ul style="list-style-type: none"> • Prior to this occurring, change the value of the system voltage to its original value. Press ENTER to save the change. • Restart the rectifier from the front panel by using the menus: <div style="text-align: center;"> </div>
8.	<p>Using the Float Settings Menu Screens, select Set Point.</p> <div style="text-align: center;"> </div>
9.	<p>Use the Arrows, and UP/DOWN keys to change the system float voltage setpoint to its original value This value must be at least 0.5V below the HV alarm threshold setting. Press ENTER to save.</p>
10.	<p>Controller Observations:</p>
	<ul style="list-style-type: none"> • The plant voltage returns to its original value • Power Major alarm (PMJ) retires • RECT and MAJ LEDs are extinguished <p>Rectifier Observations:</p> <ul style="list-style-type: none"> • Rectifier is operating normally

Battery on Discharge Alarm

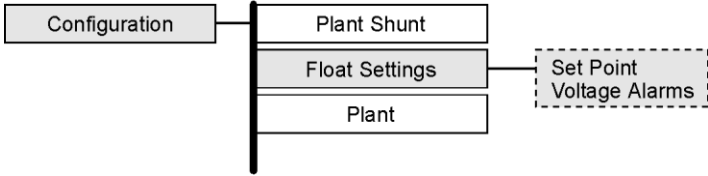
STEP	Action for Testing the Battery on Discharge Alarm
NOTE:	If the BD alarm was observed during the High Voltage Shutdown test this test can be disregarded.
1.	From the front panel follow the path(Voltage Alarms): 
2.	Note the setting of the Battery on Discharge Threshold. _____
3.	With a dummy load added to the plant, operate all rectifiers to STBY until the plant voltage drops below the BD (FLOAT) threshold.
4.	Controller Observations: <ul style="list-style-type: none"> • PMJ Alarm is active • BD and MAJ LEDs are illuminated
5.	Turn on all rectifiers
6.	Controller Observations: <ul style="list-style-type: none"> • PMJ Alarm retires • BD and MAJ LEDs are extinguished • System Voltage is normal

Rectifier Fail Alarm

The RFA alarm was observed during the High Voltage Shutdown Test so no separate test is required.

Major Fuse Alarm

Major Fuse Alarm may be tested by **placing a blown fuse** in the alarm fuse position of any distribution fuse position in the plant or by inserting a paper clip into the alarm indicating hole of its fuse holder.

For **distribution circuit breakers**, temporarily connect the pins 8 and 9 of any KS22010 or KS22012 style circuit breakers together. This is accomplished on the ED83143-30 circuit breaker panels by shorting the (-) panel bus to pin 1 on the P4 connector of its BNL1 alarm board.

Rectifier Fail Alarm(continued)

Observation:

- The DIST and MAJ LEDs and Power Major and MJF alarm relays will be active.
- Remove alarm condition and verify that DIST,MAJ LEDs and MJF relay retire.

Alarms should be tested in each distribution bay of the plant to verify the integrity of the alarm bus throughout the plant.

If the distribution bays are equipped with “Bay Fuse Alarm” indicating LEDs, also verify that this LED activates during these tests for the bay in which the alarm originates (and not in any other).

Clear History

This feature is useful when there is a need to remove unnecessary historical data from the controller. An example might be after installation and testing and the controller is ready for operation. There may be history that is of no use to the customer. Also, since the history log has a finite number of entries, user can save the history using a PC, and then clear the logs.

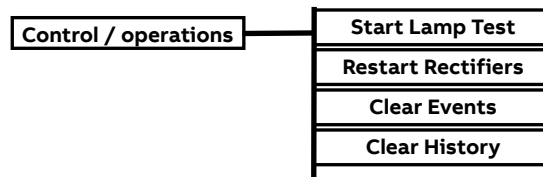

Step	Action
1.	From the Default Screen, press the Menu button for the Main Menu.
2.	Using the Up/Down Arrows, Scroll to Control/Operations and press Enter .
3.	Select Clear History , and press Enter .
4.	Press Enter again to clear the History Log, or Escape to return to the menus.

This page intentionally left blank

11. Circuit Boards

Overview

Function

Circuit boards (sometimes referred to as “cards”) are included in the battery connection and dc distribution panels to provide data to the controller.

Terminal Boards

Terminal boards are used to provide shunt voltage data to the controller, where it is used to calculate current. Terminal boards located on the battery connection panels provide data that is used to calculate battery current; data from terminal boards located on the dc distribution panels is used to calculate load current.

Alarm Boards

Alarm boards perform two functions:

- monitor panel functions and activate local indicators when faults occur on the panel
- provide alarm data to the controller

Alarm/Terminal Boards

Alarm/terminal boards combine the functions of alarm boards and terminal boards.

BLJ Terminal Board

The BLJ terminal board is located inside the cabinet door. The BLJ is the termination point for all signal cables in each cabinet and between cabinets.

Contactors Control Board

Contactors control boards provide four functions:

- Monitor and report shunt voltage to the controller
- Monitor and report contactor status to the controller
- Operate the contactor based on controller commands
- Operate or block the contactor based on maintenance switch settings

Millennium Systems

Every cabinet in a Galaxy Power System has a Bay Interface Card (BIC). The BIC provides controller access to alarm monitoring, battery voltages, battery currents, and temperature probes in the cabinet through the serial rectifier bus.

This page intentionally left blank

12. Specifications

Galaxy Power System 4827 Specifications

AC input table							
This table is for 3-wire AC input systems only. It is based on U.S. National Electric Code – Local codes supersede. For 4-wire system or systems in other countries, follow local country codes.							
Code	Nameplate Rating (input current)	External circuit breaker		Conduit Qty. & size	Wire size based on 75° C rating	Ground wire based on 75° C rating	Wire and ground lugs
		Size	Qty.				
G021	1 AC Feed at 13A, 200 VAC	150A	(1) 3- Pole	(1) 2" (1/Bay)	(3) 1/0 GA	(1) 6 GA	provided
G022	2 AC Feeds at 13A, 200 VAC	150A	(2) 3-Pole	(2) 2" (1/Bay)	(6) 1/0 GA	(2) 6 GA	provide
G026	12 AC Feeds at 15A each, 200 VAC	20A	(12) 2-pole	(1) 2" (1/Bay)	(24) 8 GA	(1) 8 GA	provided
	12 AC Feeds at 15A each, 200 VAC	20A	(12) 2-pole	(1) 1.5" (1/Bay)	(24) 8 GA	(2) 8 GA	provided
	12 AC Feeds at 15A each, 200 VAC	20A	(12) 2-pole	(4) 1" (1/Bay)	(24) 10 GA	(4) 8 GA	provided
	6 AC Feeds at 30A each, 200 VAC	40A	(6) 2-pole	(2) 1" (1/Bay)	(12) 8 GA	(2) 8 GA	provided
G027	24 AC Feeds at 15A each, 200 VAC	20A	(24) 2-pole	(3) 2" (1/Bay)	(48) 8 GA	(3) 8 GA	provided
	24 AC Feeds at 15A each, 200 VAC	20A	(24) 2-pole	(6) 1.5" (1/Bay)	(48) 10 GA	(6) 8 GA	provided
	24 AC Feeds at 15A each, 200 VAC	20A	(24) 2-pole	(8) 1" (1/Bay)	(48) 10 GA	(8) 8 GA	provided
	12 AC Feeds at 30A each, 200 VAC	40A	(12) 2-pole	(4) 1" (1/Bay)	(24) 8 GA	(4) 8 GA	provided
	8 AC Feeds at 45A each, 200 VAC	60A	(8) 2-pole	(2) 1.5" (1/Bay)	(16) 4 GA	(2) 6 GA	provided
G028	36 AC Feeds at 15A each, 200 VAC	20A	(36) 2-pole	(4) 1.5" (1/Bay)	(72) 8 GA	(4) 8 GA	provided
	36 AC Feeds at 15A each, 200 VAC	20A	(36) 2-pole	(3) 2" (1/Bay)	(72) 8 GA	(3) 8 GA	provided
	36 AC Feeds at 15A each, 200 VAC	20A	(36) 2-pole	(9) 1" (1/Bay)	(72) 10 GA	(9) 8 GA	provided
	18 AC Feeds at 30A each, 200 VAC	40A	(18) 2-pole	(3) 2" (1/Bay)	(36) 4 GA	(3) 6 GA	provided
	12 AC Feeds at 45A each, 200 VAC	60A	(12) 2-pole	(3) 2" (1/Bay)	(24) 2 GA	(3) 6 GA	provided

Cabinet output		
	1 or 2 x Full Height	Maximum System
Output Current	50 - 1800A	1800A @ 45:C

Cabinet Mechanical	
Full Height	
Nominal Cabinet Dimensions(H x W x D)	2134 H x 600 W x 600 D mm (84 H x 23.6 W x 23.6 D in.)
Units Per Initial Cabinet	
Rectifiers	1 - 36
Controller	1 per system
Battery Disconnect Modules	0 - 1
DC Distribution	1 – As many as will fit
Units Per Supplemental Cabinet	
Rectifiers	1 – 12 (Maximum 36 rectifiers per system)
Battery Disconnect Modules	0 - 1
DC Distribution	1 – As many as will fit
Environmental	
Operating AmbientTemperature	0°C to +45°C
Altitude	-50 to 4000 meters Note: For altitudes between 1500 and 4000 meters, derate the maximum temperature by 0.656°C per 100 meters.
Humidity	5% to 95% non-condensing
Radiated and Conducted Emissions	FCC Part 15, EN55022 (CISPR22), EN55024, Level A GR1089
Electromagnetic Immunity	Complies with GR1089
Earthquake Rating	Zone 4, upper floors
Standards Compliance	
Agency Approvals	CE Marked, UL Underwriters Laboratories (UL) 1950 Listed per Subject Letter S1801, DC Power Distribution Centers for Telecommunications Equipment

Rectifier

Rectifier Specifications

Electrical	
Input	
Voltage Range	95-275Vac, 2-wire, single phase
Frequency Range	45 - 66 Hz
Power Factor	> 0.98 at > 50% rated output
<p>AC Surge Protection: It is important that ac surges reaching rectifiers do not exceed the capacity of the rectifier internal surge protection. Protection must be provided external to the GPS system, if necessary, to limit surge energy reaching the rectifiers. Site surge protection must be coordinated with rectifier internal surge protection and must clamp at a lower voltage than the rectifier internal protection. The internal protection voltage and current characteristics of the rectifiers are as follows:</p>	
Phase to Phase Voltage	MOV Conduction Current
320Vac(RMS)	0A
620V maximum clamping	1mA (DC test current)
810Vpeak	100A peak
Output	
Internal Selective High Voltage Shutdown (ISHVSD)	Float: 56.0Vdc Nom. ^{1, 2} Boost: 58.5Vdc Nom. ^{1, 2}
High Voltage Shutdown (HVSD)	Float: 57.00Vdc
Output	
Output Power	2726W maximum
Output Current ¹	50Adc maximum from -40°C to +55°C 30Adc at +75°C Rectifier derates at approximately 1 ampere per degree C (+55°C to +75°C)
Float/Boost Voltage	44-58Vdc
Total Harmonic Distortion	≤5% at full load
Regulation	±0.5%
Ripple	100 mVrms
Current Limit Set Point	15A-55A

1. With Galaxy Millennium Controller
2. Factory default settings – actual range is 44 - 58Vdc

13. Safety

Please read and follow all safety instructions and warnings before servicing the GPS 4827. Reference the GPS Installation Guide and individual module product manuals for safety statements specific to the modules.

Safety Statements

Please read and follow all safety instructions and warnings before installing, maintaining, or repairing the system:

- The CE Mark demonstrates compliance with the European Union Council Directives for Low Voltage and EMC.
- The UACD is Underwriters Laboratories (UL) recognized per Subject Letter 1801, DC Power Distribution Centers for Telecommunications Equipment.
- Install only in restricted access areas (dedicated equipment rooms, equipment closets, or the like) in accordance with articles 110-26, 110-27, and 110-18 of the U.S. National Electric Code (NEC-2011), ANSI/NFPA No. 70, and pursuant to applicable local codes.
- This equipment is to be used in controlled environments (an area where the humidity is maintained at levels that cannot cause condensation on the equipment, the contaminating dust is controlled, and the steady-state ambient temperature is within the range specified).
- This equipment has been evaluated for continuous use in ambient temperature from 5°C to 55°C.
- This equipment must not be installed over combustible surfaces.
- For installations in the United States, Listed compression connectors are to be used to terminate Listed field-wired conductors where required. For all installations, the appropriate connector is to be applied only to the correct size conductor as specified by the connector manufacturer, using only the connector manufacturer's recommended tooling or tooling approved for that connector.
- The shelf in combination with the NE050AC48ATEZ has not been evaluated for hot-swapping.
- If the proper connector for the country of installation is not provided, obtain appropriate connectors and follow manufacturers and all local requirements for proper connections. All national and local rules and regulations should be followed when making field connections.
- All input and output connections comply with SELV requirements.
- Insulation on field-wired conductors should be rated no less than 90° Celsius. Size conductors based on listed recommendations. Wiring internal to enclosed equipment cabinets should be rated at 105° Celsius (minimum).
- Torque or secure electrical connections to the values specified on labels or in the product documentation.
- Alarm contacts on the office alarm connector are not fused within the controller; therefore, current limiting protection for these contacts must be provided by external circuits. Maximum ratings for alarm connections are 60Vdc and 0.5 amperes. Exceeding these maximum ratings could result in fire or damage to the unit.
- In enclosed equipment cabinets, the chassis must be connected directly to the cabinet ac service ground bus. For applications in huts, vaults, and central offices, the chassis must be connected to the system integrated ground grid.

- This product operates equally well if installed as part of the Isolated Ground Plane (Isolated Bonding Network) or the Integrated Ground Plane (Mesh- Bonding Network, aka, Common Bonding Network). OmniOn recognizes there are different grounding techniques that are equally successful. Adhere to a commonly accepted and consistent grounding approach to ensure personnel safety, network protection, and proper equipment operation. Multiple low impedance paths to Earth ground are essential.
- The equipment and subassembly ports are suitable for connection to intra- building or unexposed wiring or cabling. The equipment and subassembly ports can be connected to shielded intra-building cabling grounded at both ends.

14. Maintenance and Replacement

Requirements

System

With the exception of the batteries, periodic maintenance specific to the power system is not required. The ac service for the building must be maintained with ANSI specified limits. The temperature and humidity within the power room must be maintained

within the limits specified in this product manual.

Batteries

The batteries must be maintained as directed by the battery manufacturer's requirements.

Rectifiers

Rectifiers are repaired by replacement. Refer to "Installing or Replacing a Rectifier" in this section.

Rectifier Installation and Replacement Procedures

Installing or Replacing a Rectifier

Installing or Replacing a Rectifier	
Step	Action
1	Locate and turn off the ac service to the rectifier position that is being installed or replaced. Note: Do not turn off ac service to the entire system, only to the rectifier position that is being installed or replaced.
2	Caution Rear portion of the rectifier that is in operation may be HOT to the touch. Use appropriate precautions.
3	(This step is for replacement only. For a new installation, proceed to the next step). Open the faceplate by sliding the faceplate latch to the left until the faceplate releases and swings outward. Remove the rectifier.
4	Remove rectifier from its shipping package. Slide the rectifier into the slot approximately $\frac{3}{4}$ of the way.
5	Open the faceplate by sliding the faceplate latch to the left until the faceplate releases and swings outward.
6	Slide the rectifier into the slot until it engages with the rear of the shelf. Swing the faceplate closed to seat the rectifier. Verify the faceplate is latched.

This page intentionally left blank

15. Troubleshooting Procedure

Preliminary

Introduction

This section provides information needed in preparation for locating and interpreting visual indicators to help identify problems.

When replacing a part does not correct the problem or visual indicators do not identify a defective part, notify OmniOn Power Technical Support.

Safety

Review all safety instructions and warnings in the Safety section of the GPS Installation Guide before troubleshooting the GPS 4827.

- Hazardous ac and dc voltages and/or energy are present. Caution should be exercised. Tools must be insulated to help prevent accidental contact with live surfaces.
- Coordinate all troubleshooting activities with other personnel that may be working on the system.

Table 1: Warnings

Tools

The following tools are necessary in order to troubleshoot the GPS 4827:

- Calibrated digital voltmeter (DVM)(0.05 accuracy on dc scale)
- ESD wrist strap

Troubleshooting Procedure (continued)

Purpose

The troubleshooting procedure described below is used when a trouble condition has been identified and a technician has been dispatched to the system as a first step in diagnosing and correcting the problem.

For all trouble conditions, proceed as follows:

Cabinet Alarm

1. Locate the Galaxy controller. When a trouble condition exists, the red alarm on the top of the cabinet will be illuminated and the display screen on the controller will typically have LED's illuminated. See Figure 12-1.

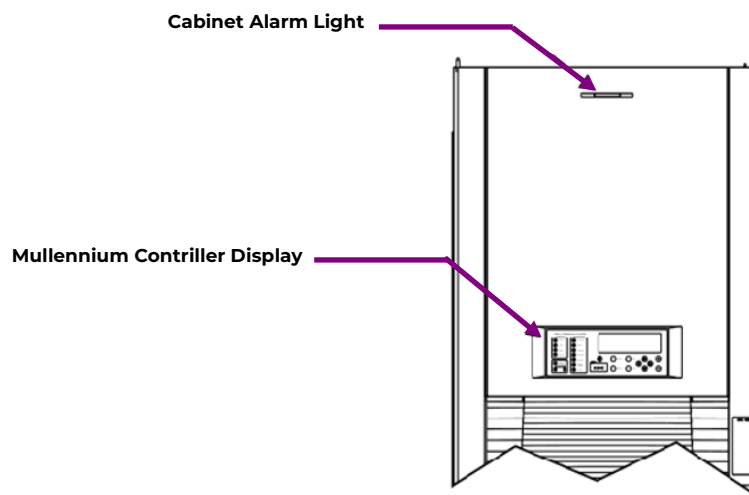

Figure 15-1: Location of cabinet alarm indicators

2. Determine the system status. For most problems, one or more alarm and status LEDs will be illuminated. Depending on the controller type, the following will be displayed:

- system voltage
- system current
- system mode
- system number of alarm/warnings

If the screen is blank, but alarm and status LEDs are illuminated, call technical support.

If the entire panel is blank, check the controller fuses. Verify that the controller is getting power.

If not, replace fuse. If the display is still blank, call technical support.

3. To view the Alarms Menu: If the default screen appears normal, press the MENU button. The main menu appears with "Alarms" blinking. Press ENTER to obtain the Alarms menu. Additional data appears that will help to identify the problem.

16. Product Warranty

A. Seller warrants to Customer only, that:

1. As of the date title to Products passes, Seller will have the right to sell, transfer, and assign such Products and the title conveyed by Seller shall be good;
2. During the warranty period stated in Sub-Article B below, Seller's Manufactured Products (products manufactured by Seller), which have been paid for by Customer, will conform to industry standards and Seller's specifications and shall be free from material defects;
3. With respect to Vendor items (items not manufactured by Seller), Seller warrants that such Vendor items, which have been paid for by Customer, will be free from material defects for a period of sixty (60) days commencing from the date of shipment from Seller's facility.

B. The Warranty Period listed below is applicable to Seller's Manufactured Products furnished pursuant to this Agreement, commencing from date of shipment from Seller's facility, unless otherwise agreed to in writing:

Product Type	New Product	Repaired Product*
Central Office Power Equipment	24 Months	6 Months

Table 1: Warranty Period

*The Warranty Period for a repaired Product or part thereof is six (6) months or, the remainder of the unexpired term of the new Product Warranty Period, whichever is longer.

C. If, under normal and proper use during the applicable Warranty Period, a defect or nonconformity is identified in a Product and Customer notifies Seller in writing of such defect or nonconformity promptly after Customer discovers such defect or nonconformity, and follows Seller's instructions regarding return of defective or nonconforming Products, Seller shall, at its option attempt first to repair or replace such Product without charge at its facility or, if not feasible, provide a refund or credit based on the original purchase price and installation charges if installed by Seller. Where Seller has elected to repair a Seller's Manufactured Product (other than Cable and Wire Products) which has been installed by Seller and Seller ascertains that the Product is not readily returnable for repair, Seller will repair the Product at Customer's site.

With respect to Cable and Wire Products manufactured by Seller which Seller elects to repair but which are not readily returnable for repair, whether or not installed by Seller, Seller at its option, may repair the cable and Wire Products at Customer's site.

D. If Seller has elected to repair or replace a defective Product, Customer shall have the option of removing and reinstalling or having Seller remove and reinstall the defective or nonconforming Product. The cost of the removal and the reinstallation shall be borne by Customer. With respect to Cable and Wire Products, Customer has the further responsibility, at its expense, to make the Cable and Wire Products accessible for repair or replacement and to restore the site. Products returned for repair or replacement will be accepted by Seller only in accordance with its instructions and procedures for such returns.

The transportation expense associated with returning such Product to Seller shall be borne by Customer. Seller shall pay the cost of transportation of the repaired or replacing Product to the destination designated by Customer.

- E. Except for batteries, the defective or nonconforming Products or parts which are replaced shall become Seller's property. Customer shall be solely responsible for the disposition of any batteries.
- F. If Seller determines that a Product for which warranty service is claimed is not defective or nonconforming, Customer shall pay Seller all costs of handling, inspecting, testing, and transportation and, if applicable, traveling and related expenses.
- G. Seller makes no warranty with respect to defective conditions or nonconformities resulting from actions of anyone other than Seller or its subcontractors, caused by any of the following: modifications, misuse, neglect, accident, or abuse; improper wiring, repairing, splicing, alteration, installation, storage, or maintenance; use in a manner not in accordance with Seller's or Vendor's specifications or operating instructions, or failure of Customer to apply previously applicable Seller modifications and corrections. In addition, Seller makes no warranty with respect to Products which have had their serial numbers or month and year of manufacture removed, altered, or experimental products or prototypes or with respect to expendable items, including, without limitation, fuses, light bulbs, motor brushes, and the like. Seller's warranty does not extend to any system into which the Product is incorporated. This warranty applies to Customer only and may not be assigned or extended by Customer to any of its customers or other users of the Product.

THE FOREGOING WARRANTIES ARE EXCLUSIVE AND ARE IN LIEU OF ALL OTHER EXPRESS AND IMPLIED WARRANTIES, INCLUDING BUT NOT LIMITED TO WARRANTIES OF MERCHANTABILITY AND FITNESS FOR A PARTICULAR PURPOSE. CUSTOMER'S SOLE AND EXCLUSIVE REMEDY SHALL BE SELLER'S OBLIGATION TO REPAIR, REPLACE, CREDIT, OR REFUND AS SET FORTH ABOVE IN THIS WARRANTY.,

17. Revision

Revision	Description	Date Dept./Init.
1.2	Updated as per template	10/08/2021
1.3	Updated as per OmniOn template	12/11/2023

OmniOn Power Inc.

601 Shiloh Rd.
Plano, TX USA

omnionpower.com

We reserve the right to make technical changes or modify the contents of this document without prior notice. OmniOn Power does not accept any responsibility for errors or lack of information in this document and makes no warranty with respect to and assumes no liability as a result of any use of information in this document.

We reserve all rights in this document and in the subject matter and illustrations contained therein. Any reproduction, disclosure to third parties or utilization of its contents – in whole or in parts – is forbidden without prior written consent of OmniOn Power. This document does not convey license to any patent or any intellectual property right. Copyright© 2023 OmniOn Power Inc. All rights reserved.