

KBVW010A0B Series (Sixteenth-Brick)

DC-DC Converter Power Modules

36 – 75V_{dc} Input; 12.0V_{dc} Output; 10A,120W Output Current

BARRACUDA* SERIES
RoHS Compliant

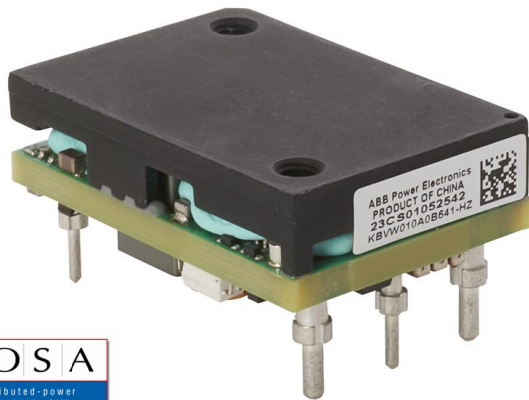

Description

The KBVW010A0B, Sixteenth-brick low-height power module is an isolated dc-dc converters that can deliver up to 10A/120W of output current and provide a precisely regulated output voltage of 12.0V over a wide range of input voltages ($V_{IN} = 36 - 75V_{dc}$). The modules achieve typical full load efficiency of 92.5%.

Applications

- Distributed Power Architectures
- Wireless Networks
- Access and Optical Network Equipment
- Enterprise Networks including Power over Ethernet (PoE)
- Industrial Equipment

Options

- Negative Remote On/Off logic (preferred)
- Over current/Over temperature/Over voltage protections (Auto-restart) (preferred)
- Heat Plate version (-H)
- For additional options, see Table 2 (Device Options) under “Ordering Information” section.

See Features & Footnotes on Page 2

Features

- Wide input voltage range: 36 – 75V_{dc}
- Monotonic startup into prebiased load
- Output Voltage adjust: 90% to 110% of V_{o, nom}
- Constant switching frequency
- Negative remote On/Off logic
- Input under voltage protection
- Output overcurrent and overvoltage protection
- Over-temperature protection
- Industry standard, DOSA compliant footprint
33.0 mm x 22.9 mm x 10.7 mm (1.30 x 0.90 x 0.42in)
- Low profile height and reduced component skyline
- High efficiency: 92.5%
- Wide operating temperature range (-40°C to 85°C)
- Compliant to RoHS Directive 2011/65/EU and amended Directive (EU) 2015/863 (-Z versions)
- Compliant to REACH Directive (EC) No 1907/2006
- ANSI/UL# 62368-1 and CAN/CSA† C22.2 No. 62368-1 Recognized, DIN VDE‡ 0868-1/A11:2017 (EN62368-1:2014/A11:2017
- CE mark meets 2014/35/EU directive[§]
- Meets the voltage and current requirements for ETSI 300- 132-2 and complies with and licensed for Basic insulation rating
- 2250 V_{dc} Isolation tested in compliance with IEEE 802.3[¶] PoE standards
- ISO**9001 and ISO 14001 certified manufacturing facilities

FOOTNOTES

* Trademark of OmniOn Power Company

UL is a registered trademark of Underwriters Laboratories, Inc.

† CSA is a registered trademark of Canadian Standards Association.

‡ VDE is a trademark of Verband Deutscher Elektrotechniker e.V.

§ This product is intended for integration into end-user equipment. All of the required procedures of end-use equipment should be followed.

¶ IEEE and 802 are registered trademarks of the Institute of Electrical and Electronics Engineers, Incorporated.

** ISO is a registered trademark of the International Organization of Standards

Technical Specifications (continued)

Absolute Maximum Ratings

Stresses in excess of the absolute maximum ratings can cause permanent damage to the device. These are absolute stress ratings only, functional operation of the device is not implied at these or any other conditions in excess of those given in the operations sections of the data sheet. Exposure to absolute maximum ratings for extended periods can adversely affect the device reliability.

| Parameter | Device | Symbol | Min | Max | Unit |
|---|--------|----------------|------|------|--------------------|
| Input Voltage | | | | | |
| Continuous | All | V_{IN} | -0.3 | 75 | V_{dc} |
| Transient Operational ($\leq 100\text{ms}$) | All | $V_{IN,trans}$ | -0.3 | 100 | V_{dc} |
| Operating Ambient Temperature (see Thermal Considerations section) | All | T_A | -40 | 85 | $^{\circ}\text{C}$ |
| Storage Temperature | All | T_{stg} | -55 | 125 | $^{\circ}\text{C}$ |
| I/O Isolation Voltage (100% factory Hi-Pot tested) | All | - | - | 2250 | V_{dc} |

Electrical Specifications

Unless otherwise indicated, specifications apply over all operating input voltage, resistive load, and temperature conditions.

| Parameter | Device | Symbol | Min | Typ | Max | Unit |
|---|--------|--------------------|-----|-----|-----|-------------------|
| Operating Input Voltage | All | V_{IN} | 36 | 48 | 75 | V_{dc} |
| Maximum Input Current ($V_{IN} = V_{IN, min}$ to $V_{IN, max}$, $I_O = I_{O, max}$) | All | $I_{IN, Max}$ | | | 3.8 | A_{dc} |
| Input No Load Current ($V_{IN} = 48\text{V}$, $I_O = 0$, module enabled) | All | $I_{IN, No load}$ | | 80 | | mA |
| Input Stand-by Current ($V_{IN} = 48\text{V}$, module disabled) | All | $I_{IN, stand-by}$ | | 4 | 6 | mA |
| Inrush Transient | All | I^2t | | | 0.5 | A^2s |
| Input Reflected Ripple Current, peak-to-peak (5Hz to 20MHz, 12 μH source impedance; $V_{IN, min}$ to $V_{IN, mix}$; $I_O = I_{O, max}$; see Test configuration section) | All | | | 30 | | mA_{p-p} |
| Input Ripple Rejection (120Hz) | All | | | 40 | | dB |

CAUTION: This power module is not internally fused. An input line fuse must always be used.

This power module can be used in a wide variety of applications, ranging from simple standalone operation to being part of complex power architecture. To preserve maximum flexibility, internal fusing is not included; however, to achieve maximum safety and system protection, always use an input line fuse. The safety agencies require a fast-acting fuse with a maximum rating of 10A (see Safety Considerations section). Based on the information provided in this data sheet on inrush energy and maximum dc input current, the same type of fuse with a lower rating can be used. Refer to the fuse manufacturer's data sheet for further information.

Technical Specifications (continued)

Electrical Specifications (continued)

| Parameter | Device | Symbol | Min | Typ | Max | Unit |
|--|-------------------|-------------------|-------------|-------------|-------------------------------------|--|
| Nominal Output Voltage Set-point ($V_{IN}=48V$, $I_O=I_{O,max}$, $T_A=25^\circ C$) | All | $V_{O, set}$ | 11.76 | 12.0 | 12.24 | V_{dc} |
| Output Voltage (Over all operating input voltage, resistive load, and temperature conditions until end of life) | All | V_O | 11.64 | - | 12.36 | V_{dc} |
| Output Regulation Line ($V_{IN}=V_{IN, min}$ to $V_{IN, max}$) Load ($I_O=I_{O, min}$ to $I_{O, max}$) Temperature ($T_{ref}=T_A$, min to T_A, max) | All All All | | - - - | - - - | ± 0.2 ± 0.2 ± 1.0 | % $V_{O, set}$ % $V_{O, set}$ % $V_{O, set}$ |
| Output Ripple and Noise ($C_O=1\mu F$, ceramic+ $10\mu F$, tantalum $V_{IN}=V_{IN, min}$ to $V_{IN, max}$, $I_O=I_{O, max}$, $T_A=25^\circ C$) RMS (5Hz to 20MHz bandwidth) Peak-to-Peak (5Hz to 20MHz bandwidth) | All All | | - - | - - | 50 180 | mV_{rms} mV_{pk-pk} |
| External Capacitance ¹ | All | $C_{O, max}$ | 100 | - | 5,000 | μF |
| Output Current | All | I_O | 0 | - | 10 | A_{dc} |
| Output Current Limit Inception (Hiccup Mode) ($V_O=90\%$ of $V_{O, set}$) | All | $I_{O, lim}$ | 110 | 130 | 160 | % I_O |
| Output Short-Circuit Current ($V_O \leq 250mV$) (Hiccup Mode) | All | $I_{O, s/c}$ | | 2.5 | | A_{rms} |
| Efficiency $V_{IN}=48V$, $T_A=25^\circ C$, $I_O=I_{O, max}$, $V_O = V_{O, set}$ | All | η | | 92.5 | | % |
| Switching Frequency | All | f_{sw} | | 450 | | kHz |
| Dynamic Load Response ($C_O=1\mu F$, ceramic+ $10\mu F$, tantalum, $dI_O/dt=0.1A/\mu s$; $V_{IN} = 48V$; $T_A=25^\circ C$) Load Change from $I_O=50\%$ to 75% or 25% to 50% of $I_{O, max}$ Peak Deviation Settling Time ($V_O < 10\%$ peak deviation) | All All | V_{pk} t_s | - - | 360 100 | - - | mV μs |

1. See Note 1 under Feature Specifications.

Isolation Specifications

| Parameter | Device | Symbol | Min | Typ | Max | Unit |
|--|--------|-----------|-----|------|------|-----------|
| Isolation Capacitance | All | C_{iso} | - | 1000 | - | pF |
| Isolation Resistance | All | R_{iso} | 10 | - | - | $M\Omega$ |
| I/O Isolation Voltage (100% factory Hi-pot tested) | All | All | - | - | 2250 | V_{dc} |

General Specifications

| Parameter | Device | Symbol | Min | Typ | Max | Unit |
|--|--------|--------|-----|------------|-----|---------------|
| Calculated Reliability based upon Telcordia SR-332 Issue 2: Method I Case 3 ($I_O=80\% \times I_{O, max}$, $T_A=40^\circ C$, airflow = 200 lfm, 90% confidence) | All | FIT | | 89.8 | | 10^9 /Hours |
| | All | MTBF | | 11,133,281 | | Hours |
| Weight (Open frame) | All | | | 16.5(0.58) | | g (oz.) |
| Weight (with Heatplate) | | | | 26.8(0.95) | | |

Technical Specifications (continued)

Feature Specifications

Unless otherwise indicated, specifications apply over all operating input voltage, resistive load, and temperature conditions. See Feature Descriptions for additional information.

| Parameter | Device | Symbol | Min | Typ | Max | Unit |
|---|--------|----------------|------|------|------|-----------------|
| Remote On/Off Signal Interface ($V_{IN}=V_{IN, min}$ to $V_{IN, max}$; open collector or equivalent, Signal referenced to V_{IN-} terminal) Negative Logic: device code suffix "1" Logic Low = module On, Logic High = module Off Positive Logic: No device code suffix required Logic Low = module Off, Logic High = module On Logic Low - Remote On/Off Current Logic Low - On/Off Voltage Logic High Voltage (Typ = Open Collector) Logic High maximum allowable leakage current | All | $I_{on/off}$ | - | - | 0.15 | mA |
| | All | $V_{on/off}$ | -0.7 | - | 0.6 | V _{dc} |
| | All | $V_{on/off}$ | 2.4 | - | 7.5 | V _{dc} |
| | All | $I_{on/off}$ | - | - | 25 | μA |
| Turn-On Delay and Rise Times ($I_O=I_{O, max}$, $V_{IN}=V_{IN, nom}$, $T_A = 25^{\circ}C$) Case 1: Input power is applied for at least 1 second, and then the On/Off input is set from OFF to ON (T_{delay} = on/off pin transition until $V_O = 10\%$ of $V_{O, set}$) Case 2: On/Off input is set to Module ON, and then input power is applied (T_{delay} = V_{IN} reaches $V_{IN, min}$ until $V_O = 10\%$ of $V_{O, set}$) Output voltage Rise time (time for V_O to rise from 10% of $V_{O, set}$ to 90% of $V_{O, set}$) | All | T_{delay} | - | 5 | - | msec |
| | All | T_{delay} | - | 5 | - | msec |
| | All | T_{rise} | - | - | 30 | msec |
| Output Voltage Overshoot - Startup $I_O=I_{O, max}$, $V_{IN}=V_{IN, min}$ to $V_{IN, max}$, $T_A=25^{\circ}C$ | All | | | - | 3 | % $V_{O, set}$ |
| Prebiased Output Load Performance: | All | Monotonic | | | | |
| Output Start up characteristic | | | | | | |
| Output Voltage Adjustment Range | All | | 90 | | 110 | % $V_{O, set}$ |
| Output Overvoltage Protection | All | $V_{O, limit}$ | - | 15 | - | V _{dc} |
| Overtemperature Protection – Hiccup Auto Restart | All | T_{ref} | - | 135 | - | °C |
| Input Undervoltage Lockout Turn-on Threshold Turn-off Threshold Hysterisis | All | V_{UVLO} | - | 34.5 | - | V _{dc} |
| | | | - | 32.5 | - | V _{dc} |
| | | | - | 2 | - | V _{dc} |

- Startup V_O rise is monotonic for $C_o \leq 2000\mu F$; otherwise V_O may dip as the control mode shifts. Operation at $<100\mu F$ is possible but output ripple may exceed specification due to a small low-frequency ripple.

Technical Specifications (continued)

Characteristic Curves

The following figures provide typical characteristics for the module at 25°C. The figures are identical for either positive or negative remote On/Off logic.

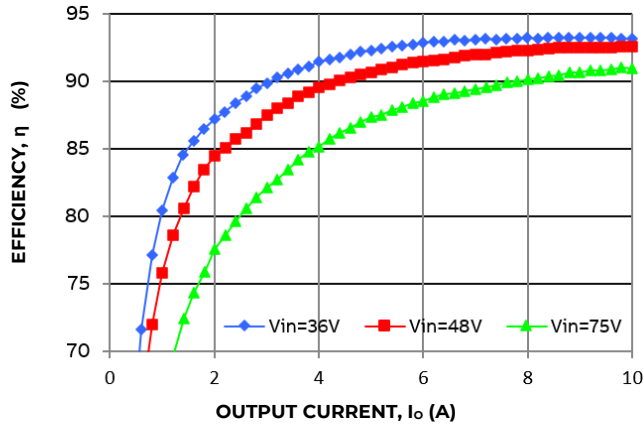

Figure 1. Converter Efficiency versus Output Current

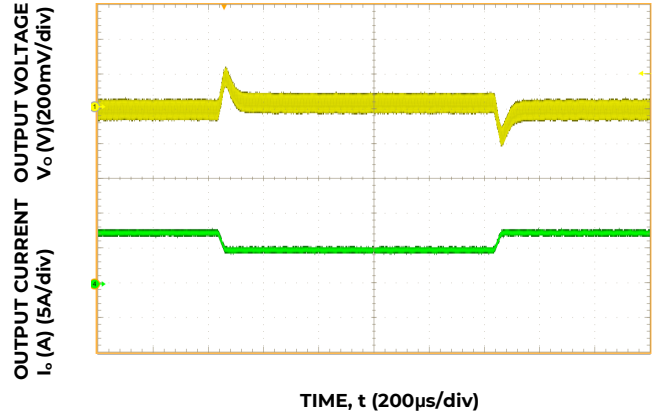

Figure 4. Transient Response to 0.1A/μs Dynamic Load Change from 50% to 75% to 50% of full load, $V_{IN} = 48V$

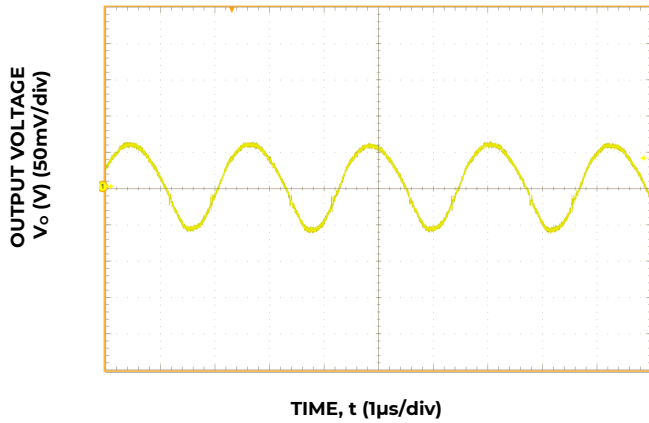

Figure 2. Typical output ripple and noise ($I_o = I_{o,max}$)

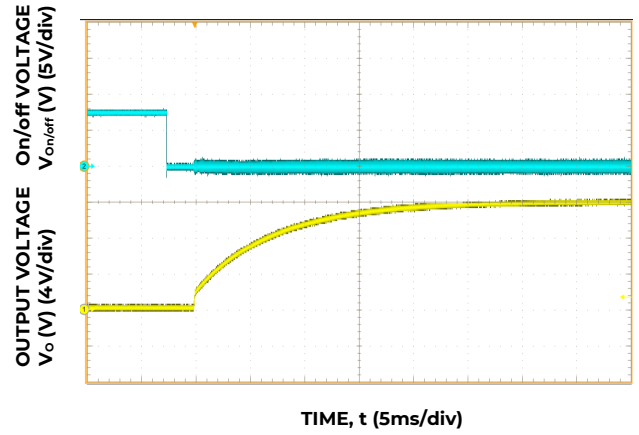

Figure 5. Typical Start-up Using Remote On/Off, negative logic version shown ($V_{IN} = 48V$, $I_o = I_{o,max}$)

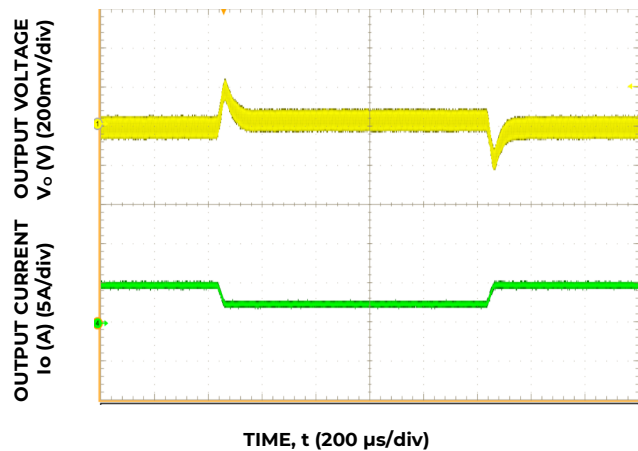

Figure 3. Transient Response to 0.1A/μs Dynamic Load Change from 25% to 50% to 25% of full load, $V_{IN} = 48V$

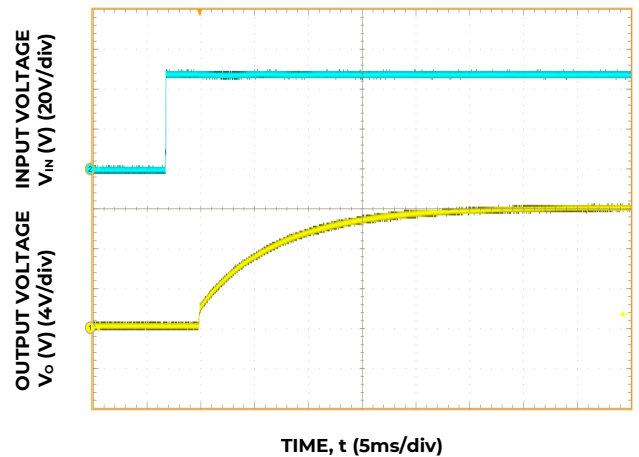

Figure 6. Typical Start-up Using Input Voltage ($V_{IN} = 48V$, $I_o = I_{o,max}$)

Technical Specifications (continued)

Test Configurations

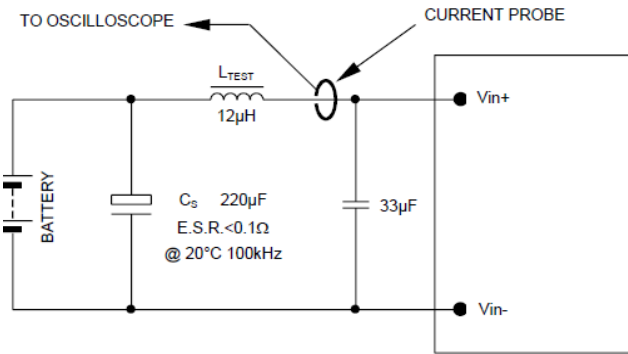

Figure 7. Input Reflected Ripple Current Test Setup.

NOTE: Measure input reflected ripple current with a simulated source inductance (L_{TEST}) of $12\mu\text{H}$. Capacitor C_S offsets possible battery impedance. Measure current as shown above.

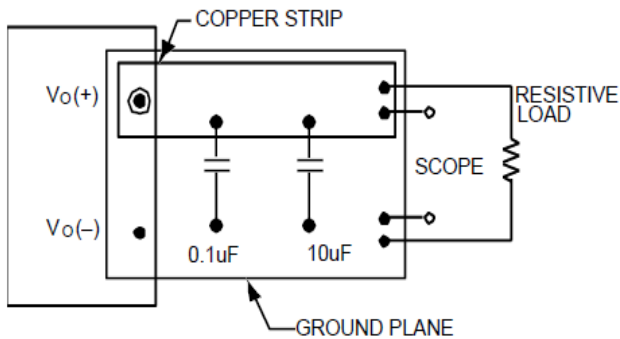

Figure 8. Output Ripple and Noise Test Setup.

NOTE: All voltage measurements to be taken at the module terminals, as shown above. If sockets are used then Kelvin connections are required at the module terminals to avoid measurement errors due to socket contact resistance.

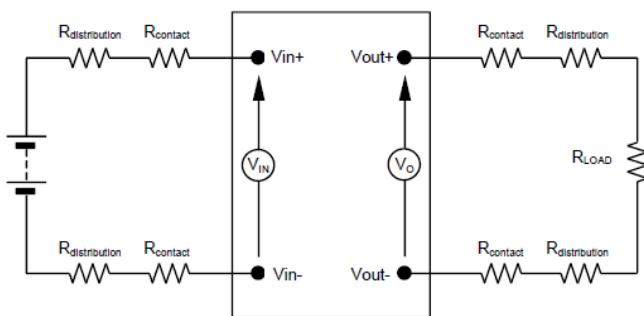

Figure 9. Output Voltage and Efficiency Test Setup.

NOTE: All voltage measurements to be taken at the module terminals, as shown above. If sockets are used then Kelvin connections are required at the module terminals to avoid measurement errors due to socket contact resistance.

$$\text{Efficiency } \eta = \frac{V_o \cdot I_o}{V_{IN} \cdot I_{IN}} \times 100\%$$

Design Considerations

Input Filtering

The power module should be connected to a low ac-impedance source. Highly inductive source impedance can affect the stability of the power module. For the test configuration in Figure 7, a $33\mu\text{F}$ electrolytic capacitor (ESR $< 0.7\Omega$ at 100kHz), mounted close to the power module helps ensure the stability of the unit. Consult the factory for further application guidelines.

Safety Considerations

For safety agency approval the power module must be installed in compliance with the spacing and separation requirements of the end-use safety agency standards, i.e., UL ANSI/UL* 62368-1 and CAN/CSA+ C22.2 No. 62368-1 Recognized, DIN VDE 0868- 1/ A11:2017 (EN62368-1:2014/A11:2017)

If the input source is non-SELV (ELV or a hazardous voltage greater than $60 V_{dc}$ and less than or equal to $75V_{dc}$), for the module's output to be considered as meeting the requirements for safety extra-low voltage (SELV) or ES1, all of the following must be true:

- The input source is to be provided with reinforced insulation from any other hazardous voltages, including the ac mains.
- One V_{IN} pin and one V_{OUT} pin are to be grounded, or both the input and output pins are to be kept floating.
- The input pins of the module are not operator accessible.
- Another SELV or ES1 reliability test is conducted on the whole system (combination of supply source and subject module), as required by the safety agencies, to verify that under a single fault, hazardous voltages do not appear at the module's output.

Technical Specifications (continued)

Safety Considerations (continued)

Note: Do not ground either of the input pins of the module without grounding one of the output pins.

This may allow a non-SELV/ES1 voltage to appear between the output pins and ground.

All flammable materials used in the manufacturing of these modules are rated 94V-0, or tested to the UL60950 A.2 for reduced thickness.

The power module has safety extra-low voltage (SELV) or ES1 outputs when all inputs are SELV or ES1.

For input voltages exceeding $-60 V_{dc}$ but less than or equal to $-75 V_{dc}$, these converters have been evaluated to the applicable requirements of BASIC INSULATION between secondary DC MAINS DISTRIBUTION input (classified as TNV-2 in Europe) and unearthed SELV outputs.

The input to these units is to be provided with a maximum 5A Fast-acting fuse in the ungrounded lead.

Feature Descriptions

Remote On/Off

Currently there is only negative logic remote On/Off, device code suffix "1", turns the module off during a logic high and on during a logic low.

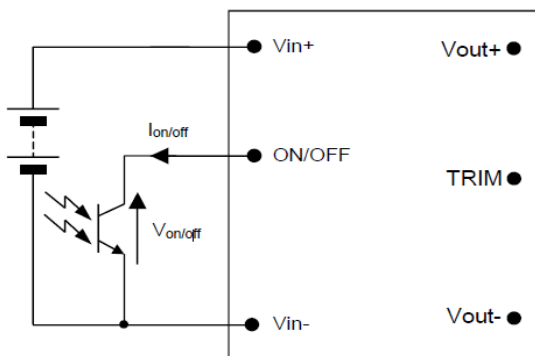

Figure 10 Remote On/Off Implementation.

To turn the power module on and off, the user must supply a switch (open collector or equivalent) to control the voltage ($V_{on/off}$) between the ON/OFF terminal and the $V_{IN(-)}$ terminal (see Figure 10). Logic low is $-0.75V \leq V_{on/off} \leq 0.6V$. The maximum $I_{on/off}$ during a logic low is 0.15mA; the switch should

maintain a logic low level whilst sinking this current.

During a logic high, the typical maximum $V_{on/off}$ generated by the module is 3.9V, and the maximum allowable leakage current at $V_{on/off} = 2.4V$ is 25 μ A.

If not using the remote on/off feature: short the ON/OFF pin to $V_{IN(-)}$.

Positive logic is not supported at this time.

Input Undervoltage Lockout

At input voltages below the input undervoltage lockout limit, the module operation is disabled. The module will only begin to operate once the input voltage is raised above the undervoltage lockout turn-on threshold, $V_{UV/ON}$.

Once operating, the module continues to operate until the input voltage is taken below the undervoltage turn-off threshold, $V_{UV/OFF}$.

Overtemperature Protection

To provide protection under certain fault conditions, the unit is equipped with a thermal shutdown circuit. The unit will shutdown if the thermal reference point T_{ref} (Figure 13), exceeds 125°C (typical), but the thermal shutdown is not intended as a guarantee that the unit will survive temperatures beyond its rating. The module can be restarted by cycling the dc input power for at least one second or by toggling the remote on/off signal for at least one second. If the auto-restart option (4) is ordered, the module will automatically restart upon cool-down to a safe temperature.

Output Overvoltage Protection

The output over voltage protection scheme of the modules has an independent over voltage loop to prevent single point of failure. This protection feature latches in the event of over voltage across the output. Cycling the on/off pin or input voltage resets the latching protection feature. If the auto restart option (4) is ordered, the module will automatically restart upon an internally programmed time elapsing.

Overcurrent Protection

To provide protection in a fault (output overload) condition, the unit is equipped with internal current-limiting circuitry and can endure current limiting continuously. At the point of current-limit inception, the unit enters hiccup mode. If the unit is not configured with auto-restart, then it will latch off following the over current condition. The module can be restarted by cycling the dc input power for at least one second or by toggling the remote on/off signal for at least one second.

Technical Specifications (continued)

If the unit is configured with the auto-restart option (4), it will remain in the hiccup mode as long as the overcurrent condition exists; it operates normally, once the output current is brought back into its specified range. The average output current during hiccup is 10% $I_{o, max}$.

Pre-Bias Startup

The module starts up monotonically into pre-biased load from $0.0V_{dc}$ up to $V_{out} - 0.6V_{dc}$.

Output Reverse Current with Pre-Bias Output Voltage

The module does not sink appreciable current (current flow into the module) that can compromise the reliability of the product. This condition is valid for either during startup or shutdown over the output pre-bias voltage range of $0.0V_{dc}$ up to $V_{out} - 0.6V_{dc}$. The test conditions for startup or shutdown are applicable for application and removal of input voltage, V_{in} or by enabling and disabling the module via remote On/Off.

Output Voltage Programming

Trimming allows the output voltage set point to be increased or decreased from the default value; this is accomplished by connecting an external resistor between the TRIM pin and either the $VO(+)$ pin or the $VO(-)$ pin.

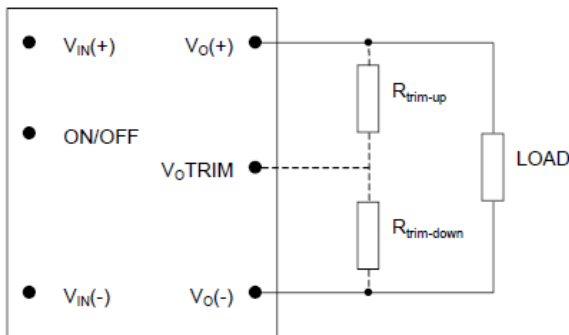

Figure 12. Circuit Configuration to Trim Output Voltage.

Connecting an external resistor ($R_{trim-down}$) between the TRIM pin and the $VO(-)$ (or Sense(-)) pin decreases the output voltage set point. To maintain set point accuracy, the trim resistor tolerance should be $\pm 1.0\%$.

The following equation determines the required external resistor value to obtain a percentage output voltage change of $\Delta\%$

$$R_{trim-down} = \left[\frac{511}{\Delta\%} - 10.22 \right] \text{ K}\Omega$$

$$\text{Where, } \Delta\% = \left(\frac{V_{o,set} - V_{desired}}{V_{o,set}} \right) \times 100$$

For example, to trim-down the output voltage of the module by 8% to 11.04V, $R_{trim-down}$ is calculated as follows:

$$\Delta\% = 8$$

$$R_{trim-down} = \left[\frac{511}{8} - 10.22 \right] \text{ K}\Omega$$

$$R_{trim-down} = 53.655 \text{ K}\Omega$$

Connecting an external resistor ($R_{trim-up}$) between the TRIM pin and the $VO(+)$ (or Sense (+)) pin increases the output voltage set point. The following equation determines the required external resistor value to obtain a percentage output voltage change of $\Delta\%$:

$$R_{trim-up} = \left[\frac{511 \times V_{o,set} \times (100 + \Delta\%)}{1.225 \times \Delta\%} - \frac{511}{\Delta\%} - 10.22 \right] \text{ K}\Omega$$

$$\text{Where } \Delta\% = \left(\frac{V_{desired} - V_{o,set}}{V_{o,set}} \right) \times 100$$

For example, to trim-up the output voltage of the module by 5% to 5.2V, $R_{trim-up}$ is calculated is as follows:

$$\Delta\% = 5$$

$$R_{trim-up} = \left[\frac{511 \times 12.0V \times (100 + 5\%)}{1.225 \times 5} - \frac{511}{5} - 10.22 \right] \text{ K}\Omega$$

$$R_{trim-down} = 938.8 \text{ K}\Omega$$

Technical Specifications (continued)

The voltage between the $V_o(+)$ and $V_o(-)$ terminals must not exceed the minimum output overvoltage protection value shown in the Feature Specifications table. This limit includes any increase in voltage due to remote-sense compensation and output voltage set-point adjustment trim.

Although the output voltage can be increased by both the remote sense and by the trim, the maximum increase for the output voltage is not the sum of both. The maximum increase is the larger of either the remote sense or the trim. The amount of power delivered by the module is defined as the voltage at the output terminals multiplied by the output current. When using remote sense and trim, the output voltage of the module can be increased, which at the same output current would increase the power output of the module. Care should be taken to ensure that the maximum output power of the module remains at or below the maximum rated power (Maximum rated power = $V_{o,set} \times I_{o,max}$).

Thermal Considerations

The power modules operate in a variety of thermal environments; however, sufficient cooling should be provided to help ensure reliable operation.

Considerations include ambient temperature, airflow, module power dissipation, and the need for increased reliability. A reduction in the operating temperature of the module will result in an increase in reliability. The thermal data presented here is based on physical measurements taken in a wind tunnel.

The thermal reference point, used in the specifications is shown in Figure 13. For reliable operation this temperature T_{ref1} should not exceed 124.1°C and T_{ref2} should not exceed 110°C .

The thermal reference point, T_{ref3} , used in the specifications for modules with heatplate is shown in Figure 14. For reliable operation this temperature should not exceed 112°C .

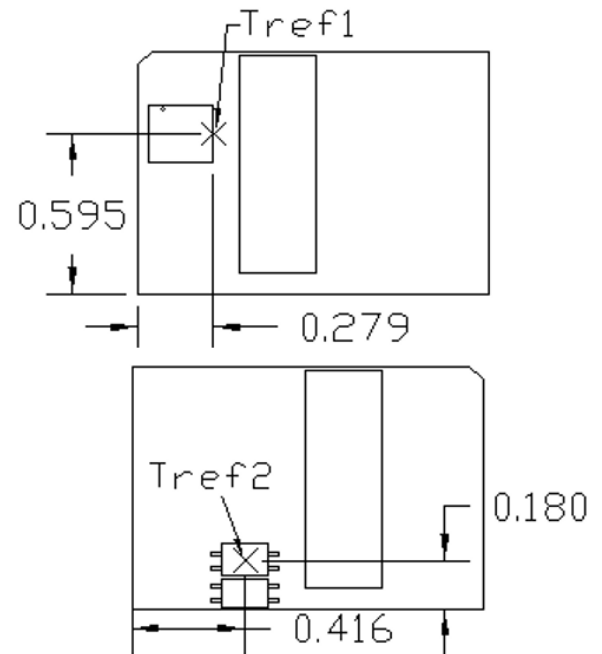

Figure 13. T_{ref} Temperature Measurement Locations for Open Frame Module.

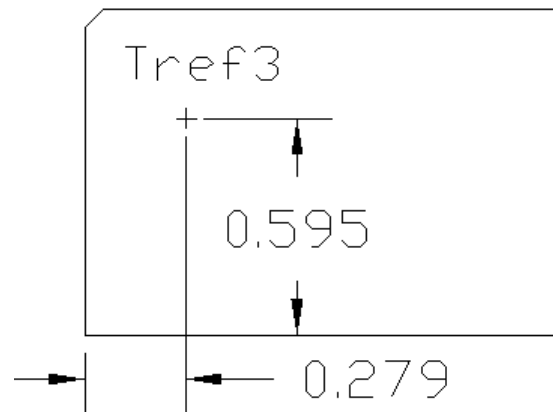

Figure 14. T_{ref} Temperature Measurement Location for Module with Heatplate.

Technical Specifications (continued)

Heat Transfer via Convection

Increased airflow over the module enhances the heat transfer via convection. Derating curves showing the maximum output current that can be delivered by each module versus local ambient temperature (T_A) for natural convection and up to 3m/s (600 LFM) forced airflow are shown in Figures 15 & 16 a.

Please refer to the Application Note “Thermal Characterization Process For Open-Frame Board-Mounted Power Modules” for a detailed discussion of thermal aspects including maximum device temperatures.

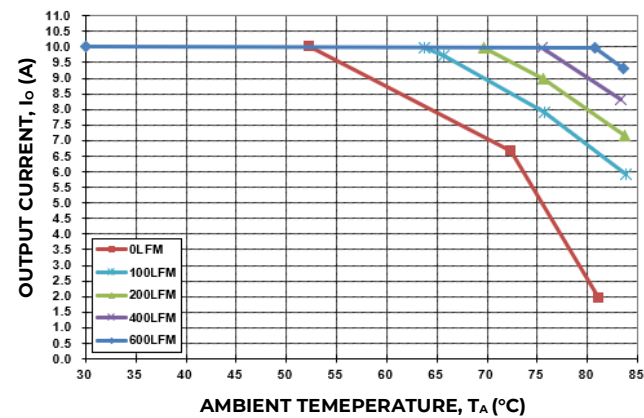

Figure 15. Output Current Derating for the Open Frame Module; Airflow in the Transverse Direction from $V_{out}(+)$ to $V_{out}(-)$; $V_{IN}=48V$.

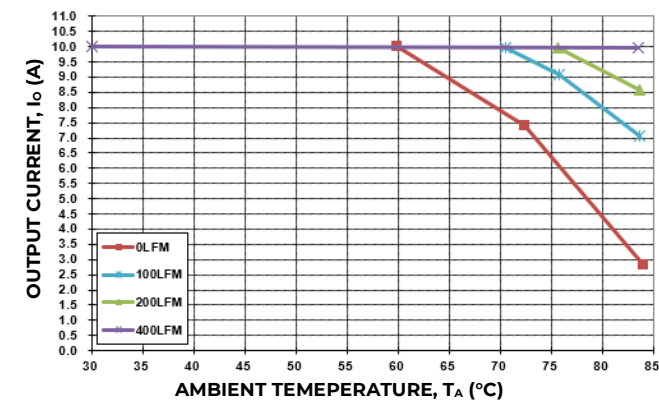

Figure 16a. Output Current Derating for the Module with Heatplate; Airflow in the Transverse Direction from $V_{out}(+)$ to $V_{out}(-)$; $V_{IN}=48V$.

Heat Sink Application

The heatplate used on the module has tapped holes for heat sink. And a heat sink can also be attached using adhesives made for this purpose. When curing these types of adhesives, do not exceed the maximum storage temperature of 125°C.

Heat Transfer via Conduction

Modules with heat plate option (-H) can also be used in cold wall applications for heat transfer via conduction cooling. Fig 16b&16c show the setup and derating curve for this application.

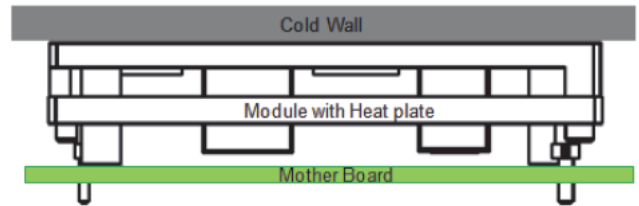

Figure 16b. Coldwall application setup

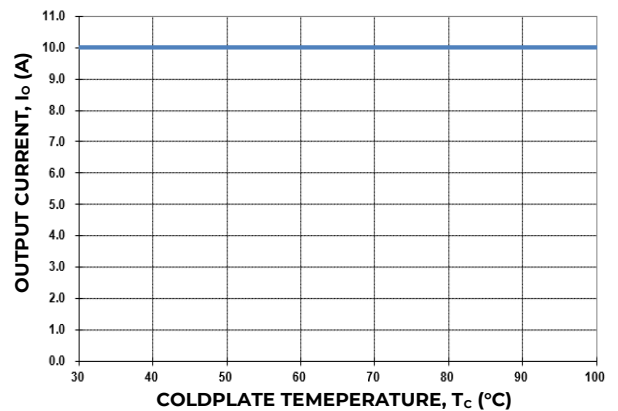

Figure 16c. Output Current Derating for the Module with Heatplate in a cold wall application; $V_{IN}=36-75V$.

Technical Specifications (continued)

Tin Lead Soldering

The power modules are lead free modules and can be soldered either in a lead-free solder process or in a conventional Tin/Lead (Sn/Pb) process. It is recommended that the customer review data sheets in order to customize the solder reflow profile for each application board assembly. The following instructions must be observed when soldering these units. Failure to observe these instructions may result in the failure of or cause damage to the modules, and can adversely affect long term reliability.

In a conventional Tin/Lead (Sn/Pb) solder process peak reflow temperatures are limited to less than 235°C (see Figs 18 and 19). Typically, the eutectic solder melts at 183°C, wets the land, and subsequently wicks the device connection. Sufficient time must be allowed to fuse the plating on the connection to ensure a reliable solder joint. There are several types of SMT reflow technologies currently used in the industry. These surface mount power modules can be reliably soldered using natural forced convection, IR (radiant infrared), or a combination of convection/IR. For reliable soldering the solder reflow profile should be established by accurately measuring the modules CP connector temperatures.

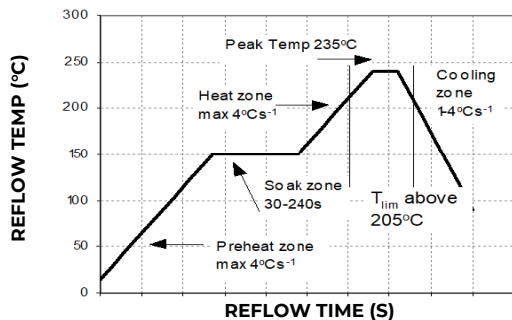

Figure 18. Reflow Profile for Tin/Lead (Sn/Pb) process.

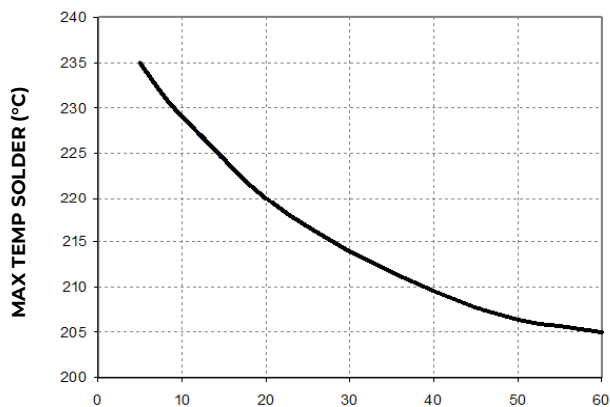

Figure 19. Time Limit Curve Above 205°C for Tin/Lead (Sn/Pb) process

Lead Free Soldering

The –Z version of the modules are lead-free (Pb-free) and RoHS compliant and are both forward and backward compatible in a Pb-free and a SnPb soldering process. Failure to observe the instructions below may result in the failure of or cause damage to the modules and can adversely affect long-term reliability.

Pb-free Reflow Profile

Power Modules (with the exception of modules that come with heat plate option –H) will comply with J-STD-020 Rev. C (Moisture/Reflow Sensitivity Classification for Nonhermetic Solid State Surface Mount Devices) for both Pb-free solder profiles and MSL classification procedures. This standard provides a recommended forced-air-convection reflow profile based on the volume and thickness of the package (Table 4-2). The suggested Pb-free solder paste is Sn/Ag/Cu (SAC). The recommended linear reflow profile using Sn/Ag/Cu solder is shown in Figure 20.

MSL Rating

The modules have a MSL rating as indicated in the Device Codes table, last page of this document.

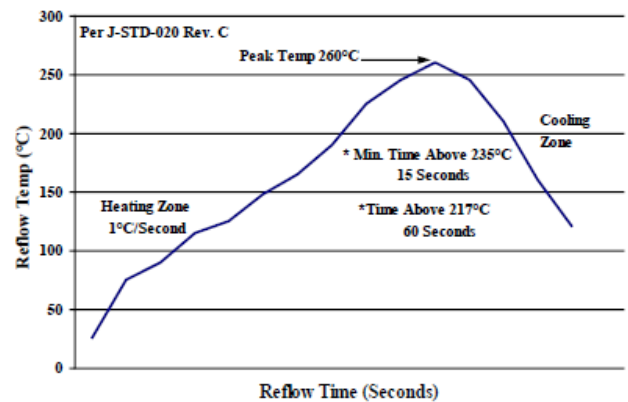

Figure 20. Recommended linear reflow profile using Sn/Ag/Cu solder.

Technical Specifications (continued)

Through-Hole Lead-Free Soldering

Information The RoHS-compliant, Z option, through-hole products use the SAC (Sn/Ag/Cu) Pb-free solder and RoHS-compliant components. They are designed to be processed through single or dual wave soldering machines. The pins have a RoHS-compliant, pure tin finish that is compatible with both Pb and Pb-free wave soldering processes. A maximum preheat rate of 3°C/s is suggested. The wave preheat process should be such that the temperature of the power module board is kept below 210°C. For Pb solder, the recommended pot temperature is 260°C, while the Pb-free solder pot is 270°C max.

Reflow Lead-Free Soldering Information

The RoHS-compliant through-hole products (with the exception of modules that come with heat plate option – H) can be processed with the following paste-through-hole Pb or Pb-free reflow process. Max. sustain temperature:

245°C (J-STD-020C Table 4-2: Packaging Thickness $\geq 2.5\text{mm}$ / Volume $> 2000\text{mm}^3$),

Peak temperature over 245°C is not suggested due to the potential reliability risk of components under continuous high-temperature.

Min. sustain duration above 217°C: 90 seconds

Min. sustain duration above 180°C: 150 seconds

Max. heat up rate: 3°C/sec

Max. cool down rate: 4°C/sec

In compliance with JEDEC J-STD-020C spec for 2 times reflow requirement.

Pb-free Reflow Profile

BMP module (with the exception of modules that come with heat plate option –H) will comply with J-STD-020 Rev. C (Moisture/Reflow Sensitivity Classification for Nonhermetic Solid State Surface Mount Devices) for both Pb-free solder profiles and MSL classification procedures. BMP will comply with JEDEC J-STD-020C specification for 3 times reflow requirement. The suggested Pb-free solder paste is Sn/Ag/Cu (SAC). The recommended linear reflow profile using Sn/Ag/Cu solder is shown in Figure 21.

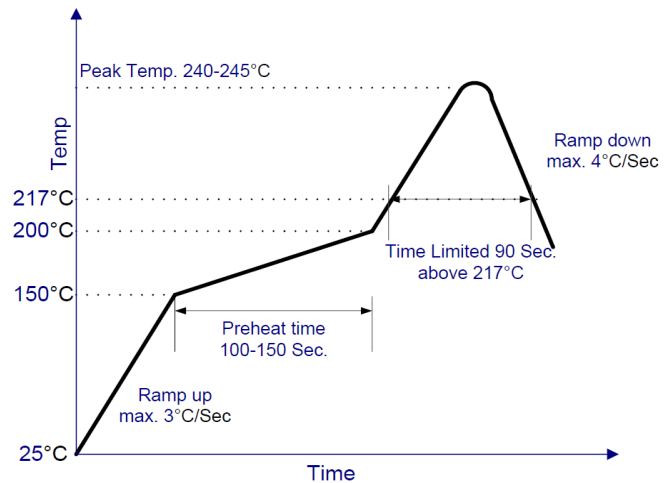

Figure 21. Recommended linear reflow profile using Sn/Ag/Cu solder.

Storage and Handling

The recommended storage environment and handling procedures for moisture-sensitive surface mount packages is detailed in J-STD-033 Rev. A (Handling, Packing, Shipping and Use of Moisture/Reflow Sensitive Surface Mount Devices). Moisture Barrier Bags (MBB) with desiccant are required for MSL ratings of 2 or greater. These sealed packages should not be broken until time of use. Once the original package is broken, the floor life of the product at conditions of $\leq 30^\circ\text{C}$ and 60% relative humidity varies according to the MSL rating (see J-STD-033A). The shelf life for dry packed SMT packages will be a minimum of 12 months from the bag seal date, when stored at the following conditions: $< 40^\circ\text{C}$, $< 90\%$ relative humidity.

Post Solder Cleaning and Drying Considerations

Post solder cleaning is usually the final circuit-board assembly process prior to electrical board testing. The result of inadequate cleaning and drying can affect both the reliability of a power module and the testability of the finished circuit-board assembly. For guidance on appropriate soldering, cleaning and drying procedures, refer to OmniOn Power Board Mounted Power Modules: Soldering and Cleaning Application Note (AN04-001)

Technical Specifications (continued)

EMC Considerations

The circuit and plots in Figure 22 show a suggested configuration to meet the conducted emission limits of EN55032 Class A.

Note: Customer is ultimately responsible for the proper layout, component selection, rating and verification of the suggested parts based on end application.

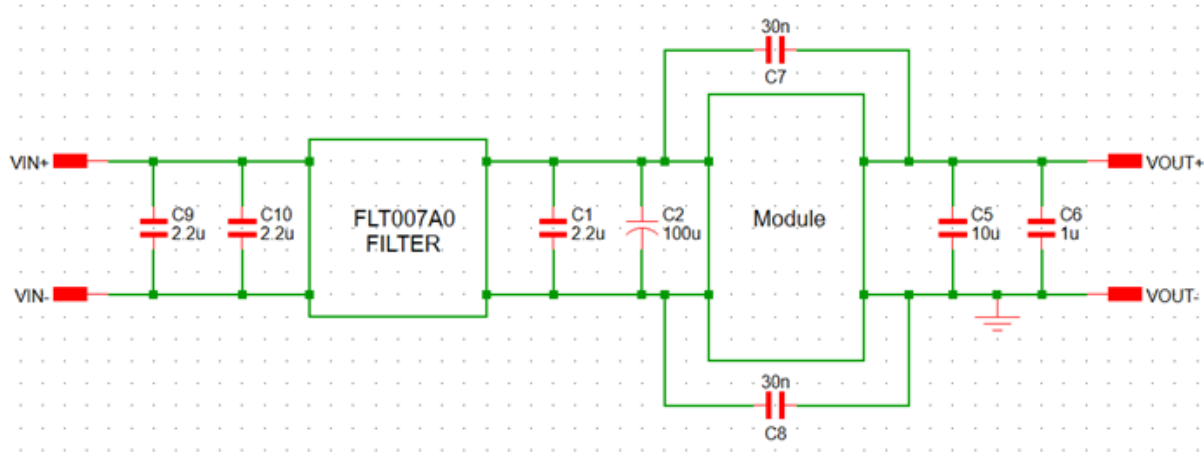

| Reference | Description | MPN |
|-----------|-----------------------------|-----------------|
| C1 | X7R 2.2uF 100V 1210 SIZE | C1210X225K101TX |
| C2 | 100uF 100V | UPW2A101MPD |
| C5 | 10uF 25V | TAJD106K025ESA |
| C6 | 1uF 50V | C3216X7R1H105KT |
| C7 | 3pcs 10nF 1000V in parallel | C1808X103K102T |
| C8 | 3pcs 10nF 1000V in parallel | C1808X103K102T |
| C9 | X7R 2.2uF 100V 1210 SIZE | C1210X225K101TX |
| C10 | X7R 2.2uF 100V 1210 SIZE | C1210X225K101TX |
| Filter | Two stage EMI filter | FLT007A0 |

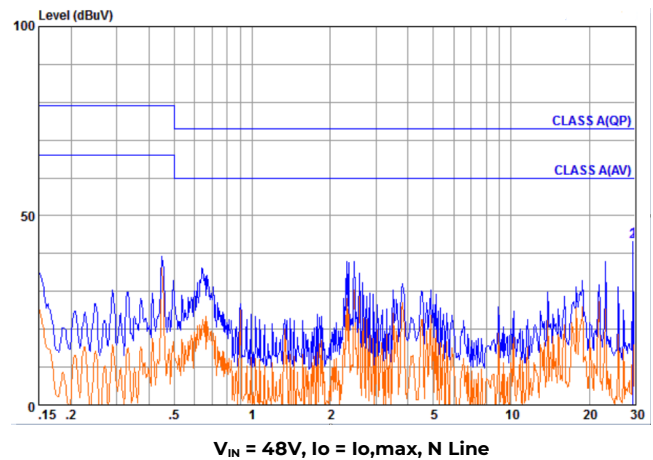
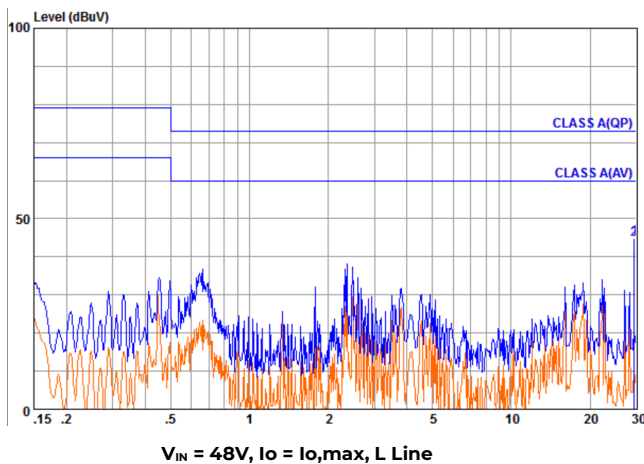

Figure 22. EMC Considerations

For further information on designing for EMC compliance, please refer to the FLT007A0 data sheet (DS05-028).

Technical Specifications (continued)

Mechanical Outline for Through-Hole Module

Dimensions are in millimeters and [inches].

Tolerances: x.x mm ± 0.5 mm [x.xx in. ± 0.02 in.] (unless otherwise indicated)

x.xx mm ± 0.25 mm [x.xxx in. ± 0.010 in.]

TOP VIEW

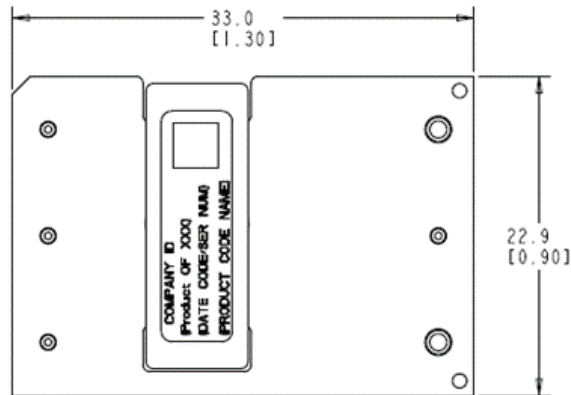

SIDE VIEW

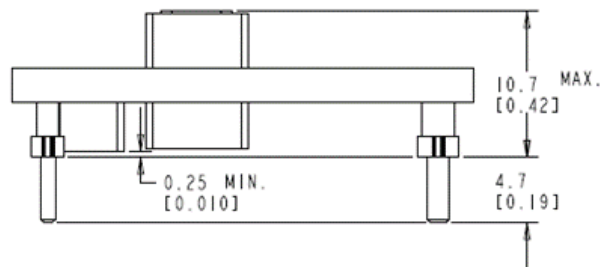

BOTTOM VIEW

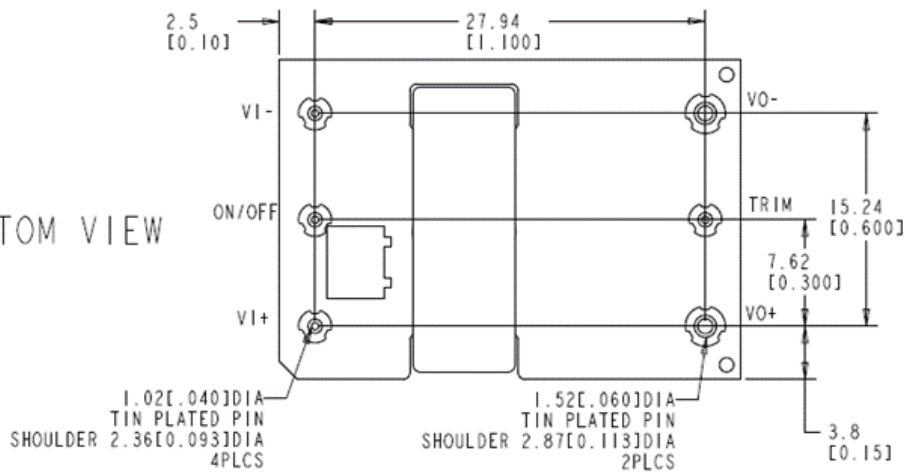

| Pin | Function |
|-----|---------------------|
| 1 | V _{IN} (+) |
| 2 | ON/OFF |
| 3 | V _{IN} (-) |
| 4 | V _O (-) |
| 5 | TRIM |
| 6 | V _O (+) |

Technical Specifications (continued)

Mechanical Outline for Through-Hole Module with Heat Plate (-H Option)

Dimensions are in millimeters and [inches].

Tolerances: x.x mm ± 0.5 mm [x.xx in. ± 0.02 in.] (unless otherwise indicated)

x.xx mm ± 0.25 mm [x.xxx in. ± 0.010 in.]

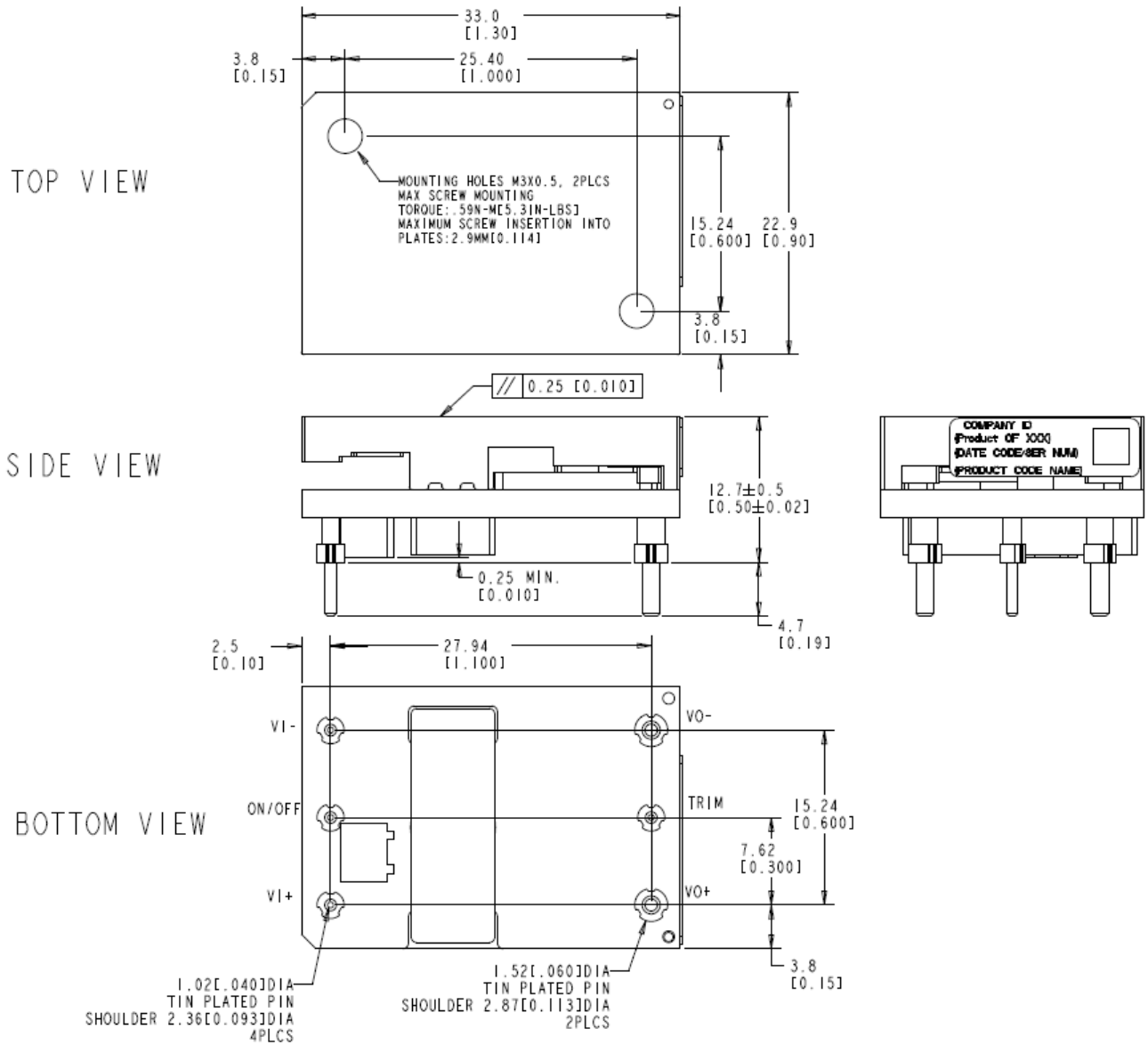

| Pin | Function |
|-----|---------------------|
| 1 | V _{IN} (+) |
| 2 | ON/OFF |
| 3 | V _{IN} (-) |
| 4 | V _O (-) |
| 5 | TRIM |
| 6 | V _O (+) |

Technical Specifications (continued)

Recommended Pad Layout

Dimensions are in millimeters and [inches].

Tolerances: x.x mm ± 0.5 mm [x.xx in. ± 0.02 in.] (Unless otherwise indicated)

x.xx mm ± 0.25 mm [x.xxx in ± 0.010 in.]

| Pin | Function |
|-----|---------------------|
| 1 | V _{IN} (+) |
| 2 | ON/OFF |
| 3 | V _{IN} (-) |
| 4 | V _o (-) |
| 5 | TRIM |
| 6 | V _o (+) |

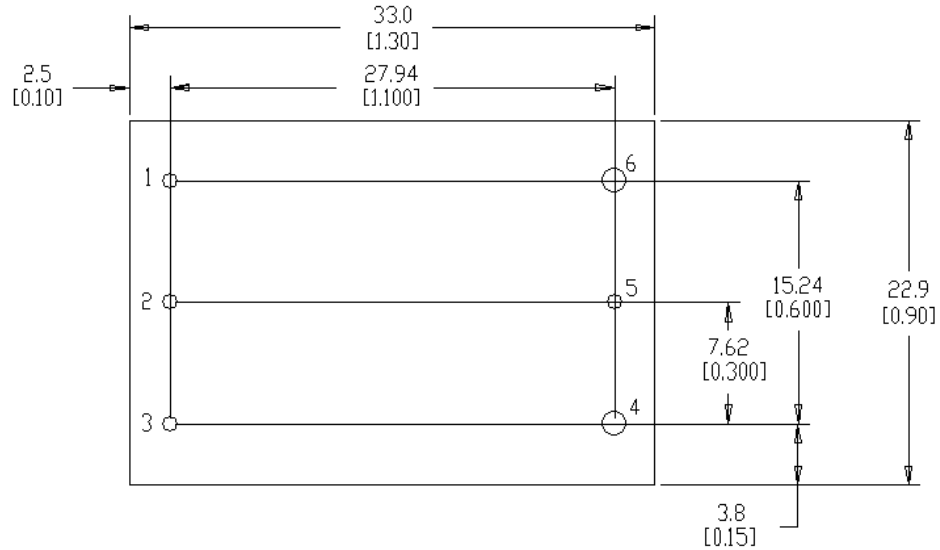

TH Recommended Pad Layout (Top Side View)

| Pin Number | Hole Dia mm [in] | Pad Dia mm [in] |
|------------|------------------|-----------------|
| 1, 2, 3,5 | 1.6 [.063] | 2.1 [.083] |
| 4,6 | 2.3 [.091] | 3.3 [.130] |

Packaging Details

KBVW010XXX open frame version is supplied in plastic trays and 75pcs/box.

Each tray contains a total of 25 power modules. Each shipping box contains 3 full trays and an empty tray on top giving a total number of 75pcs power modules.

KBVW010XXX-HZ is supplied in foam trays and 84pcs/box.

Each foam tray contains a total of 28 power modules. Each shipping box contains 3 full trays giving a total number of 84pcs power modules.

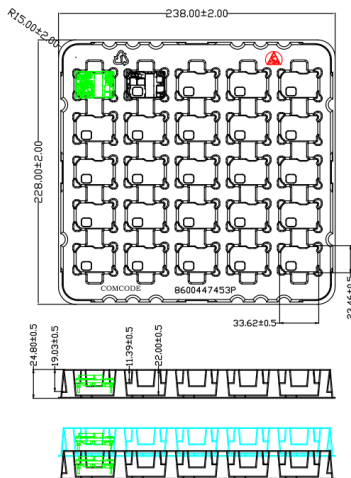

Package view for -Z version

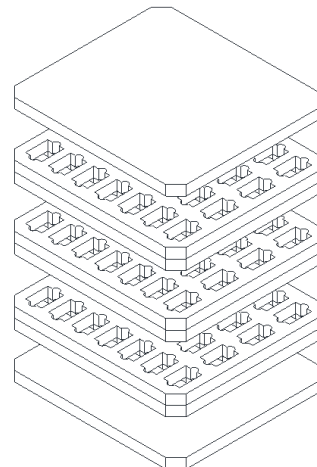

Package view for HZ version

Technical Specifications (continued)

Ordering Information

Please contact your OmniOn Power Sales Representative for pricing, availability and optional features.

| Product Code | Input Voltage | Output Voltage | Output Current | On/Off Logic | Connector Type | MSL Rating | Ordering Codes |
|------------------|-----------------------------|----------------|----------------|--------------|----------------|------------|----------------|
| KBVW010A0B641-HZ | 48V (36-75V _{dc}) | 12.0V | 10A | Negative | Through hole | 2a | 1600415426A |
| KBVW010A0B641Z | 48V (36-75V _{dc}) | 12.0V | 10A | Negative | Through hole | 2a | 1600415425A |
| KBVW010A0B841-HZ | 48V (36-75V _{dc}) | 12.0V | 10A | Negative | Through hole | 2a | 1600484219A |

Table 1. Device Codes

| Characteristic | | Character and Position | | | | | | | | | | Definition | | |
|----------------|--------------------------------------|------------------------|--|--|-------|---|--|---|---|---|--|------------|---|---|
| Ratings | Form Factor | K | | | | | | | | | | | K = Sixteenth Brick | |
| | Family Designator | BV | | | | | | | | | | | BV = BARRACUDA Series | |
| | Input Voltage | W | | | | | | | | | | | W = Wide Range, 36V-75V | |
| | Output Current | | | | 010A0 | | | | | | | | 010A0 = 010.0 Amps Maximum Output Current | |
| | Output Voltage | | | | | B | | | | | | | B = 12.0V nominal | |
| Options | Pin Length | | | | | | | 6 | 8 | | | | | Omit = Default Pin Length shown in Mechanical Outline Figures 6 = Pin Length: 3.68 mm ± 0.25mm , (0.145 in. ± 0.010 in.) 8 = Pin Length: 2.79 mm ± 0.25mm , (0.110 in. ± 0.010 in.) |
| | Action following Protective Shutdown | | | | | | | | 4 | | | | | Omit = Latching Mode 4 = Auto-restart following shutdown (Overcurrent/ Overvoltage) |
| | On/Off Logic | | | | | | | | | 1 | | | | Omit = Positive Logic 1 = Negative Logic |
| | Customer Specific | | | | | | | | | | | XY | XY = Customer Specific Modified Code, Omit for Standard Code 21 = Meets 100us Vin dropout test with minimal external Cin | |
| | Mechanical Features | | | | | | | | | | | | SR H | Omit = Standard open Frame Module SR = Surface mount connections & tape/reel package H = Heat plate, for use with heat sinks |
| | RoHS | | | | | | | | | | | | | Z |

Table 2. Device Coding Scheme and Options

Contact Us

For more information, call us at

1-877-546-3243 (US)

1-972-244-9288 (Int'l)

Change History (excludes grammar & clarifications)

| Revision | Date | Description of the change |
|----------|------------|---|
| 1.0 | 10/18/2022 | First release |
| 1.1 | 2/15/2023 | Update outlook for heatplate version |
| 1.2 | 4/20/2023 | Minor edits including page footer |
| 1.3 | 5/5/2023 | Update heatsink application in page 11 |
| 1.4 | 6/16/2023 | Added product photo (p.1) |
| 1.5 | 11/02/2023 | Updated as per OmniOn template |
| 1.6 | 04/01/2024 | Added new Ordering code and updated MSL rating. |

OmniOn Power Inc.

601 Shiloh Rd.
Plano, TX USA

omnionpower.com

We reserve the right to make technical changes or modify the contents of this document without prior notice. OmniOn Power does not accept any responsibility for errors or lack of information in this document and makes no warranty with respect to and assumes no liability as a result of any use of information in this document.

We reserve all rights in this document and in the subject matter and illustrations contained therein. Any reproduction, disclosure to third parties or utilization of its contents – in whole or in parts – is forbidden without prior written consent of OmniOn Power. This document does not convey license to any patent or any intellectual property right. Copyright© 2024 OmniOn Power Inc. All rights reserved.