

DATASHEET

EV100H3N1K/EV101H3N1K DC Fast Charger For Electric Vehicle Applications

Input: 260 – 530 Vac; Output: 150 – 1000Vdc (30kW@300 – 1000Vdc)



The EV100H3N1K/EV101H3N1K is a direct current fast-charger rectifier specifically designed to meet the unique needs in electric vehicle (EV) charger applications. The rectifier has a very wide output voltage range which starts from 150Vdc to 1000Vdc and can keep constant power of 30kW from 300Vdc to 1000Vdc with maximum output current of 100Adc. This broad output charging range combined with the rectifier's high operating efficiency – greater than 96% efficiency in optimum conditions – make it an ideal solution for current and future EV charging infrastructure. In addition, the rectifier's modular, self-contained, air-cooled chassis helps enable rapid serviceability and parallelable installations. EV charger once shutdown due to any protection, auto restart is not permitted unless system send restart command.

Application

- Electric Vehicle

Features

- Size: 300*84*435 millimeters or 11.81*3.31*17.13 inches (W*H*D, width not including mounting ears)
- Three-phase input nominal voltage: 400Vac/480Vac
- Output voltage of 150 to 1,000 – Volts DC (settable)
- Operating temperature range of -40 to 70°C
- Maximum output power of 30 kilowatts (kW) at 55°C
- Peak efficiency >96%
- Output High voltage mode (HV 150Vdc – 1000Vdc), Low voltage mode (LV 150Vdc – 500Vdc) operation (Fig.4)
- Power density: 44.8 W/inch³
- CANOpen communications
- Output over current protection and over voltage protection
- Input Under/over – voltage protection
- Over-temperature protection
- Remote firmware upgradable
- Design life is 10 years (with maintenance)
- cTUVus approval, CE mark available

Technical Specifications

Environmental Specifications

Parameter	Min	Typ	Max	Units	Notes
Ambient temperature					
Operating*	-40		+70	°C	Derating from 55°C. Fig.1
Storage	-40		+85	°C	
Operating Altitude			4000	m	Derating from 2000m
Installation type					In IP54 cabinet
Cooling					Forced air cooling with FAN's
Expected life of fan					
		70,000		hours	Ambient temperature 45°C
		40,000		hours	Ambient temperature 60°C
Pollution degree					PD2
Humidity					
Operating			95%		Relative humidity, non-condensing
Storage			95%		Relative humidity, non-condensing
Coating					Conformal coating
MTBF		700,000		hours	Ambient temperature 40°C
Acoustic Noise					
		60.8		dB	Input 400Vac; Output LV 350V/Full load/Ambient temperature 35°C
		60.4		dB	Input 400Vac; Output HV 750V/Full load/Ambient temperature 35°C
Vibration - sine sweep (non-operation)					IEC 60068-2-6
Vibration - random (non-operation)					IEC60068-2-64
Shock - half-sine (non-operation)					IEC60068-2-27
Salt Mist					IEC60068-2-52

*below -20°C, output current will be automatically limited at startup and it will automatically increase to the target current after module internal temperature has warmed up.

Electrical items

AC specifications

Parameter	Specification	Notes
Grid Type	TN, TT	
AC rated input voltage	Three – phase Line – to – Line 400 Vac/ 480Vac	(AC input 3Wire + PE)
AC input voltage range	260Vac~530Vac derating from 323Vac	Fig.2
AC input frequency	45-65Hz	
Maximum input current	60 A	
Power factor	>0.99@ full load	rated input
Total harmonic current	< 5% @50% – 100% input current	rated input
Voltage unbalance	10% unbalance (and still working nominal)	Single phase dip and up 10% Two phases dip and up 10%
Input impulse current	<110% rated current peak value	rated input
Input inrush current	<150% rated current peak value	rated input

Technical Specifications (continued)

DC specifications

Parameter	Specification	Notes
Output voltage range	150 – 1000Vdc	Fig.3
Rated power	30kW	
Maximum output current	100 A	Fig.3
Efficiency	≥96% peak	rated input
Voltage deviation	<0.5%	
Current deviation	≤1% @Io≥30A; ≤0.3A @Io<30A	
Output voltage ripple		Peak – to – peak, 20MHz bandwidth
@Input 400Vac; Output LV 350V/Full load/ resistor load	1.0V (typical)	Fig.5
@Input 400Vac; Output HV 750V/Full load/ resistor load	1.4V (typical)	Fig.6
Output current ripple		Peak-to-peak, 150kHz bandwidth
@Input 400Vac; Output LV 350V/Full load/ with 5600uF cap	2.2A (typical)	Fig.7
@Input 400Vac; Output HV 750V/Full load/ with 5600uF cap	1.4A (typical)	Fig.8
Current regular speed	25A/s (typical)	from current value to target value speed in CC mode
Voltage drop time after receiving stop command from CAN	≤ 900ms to less than 60V	from current value to 60V
Voltage slew rate in normal operation	1000V/s (typical)	
Voltage overshoot after load dump	< 110% of the requested voltage	IEC61851-23 ed2 clause 101.2.1.7
Passive discharge	< 60V within 240seconds	
EPO Function	EVI01 Product	Normally Closed, Signal Pins 3,4 12V ± 10% externally sourced

Technical Specifications (continued)

Input protection

Parameter	Typical	Notes
Under-voltage protection	255±5Vac	PFC stage recover automatically, output restart need system send restart command
Over-voltage protection	535±5Vac	PFC stage recover automatically, output restart need system send restart command
Voltage unbalance protection	≥11%	PFC stage recover automatically, output restart need system send restart command

Output protection

Item	Typical	Notes
Over voltage protection	1050 ± 10V	Output restart need system send restart command
Short protection	1.5 In	Output restart need system send restart command

Characteristic Curves

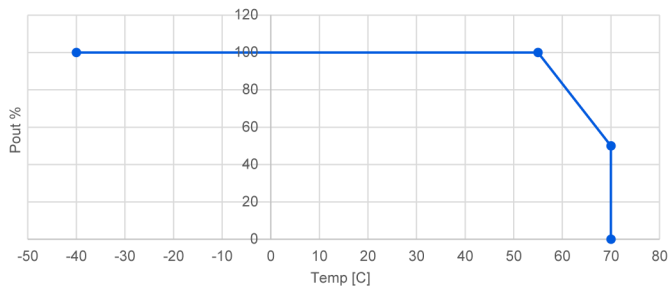

Fig.1 Temperature Limited Power Curve (Note1)

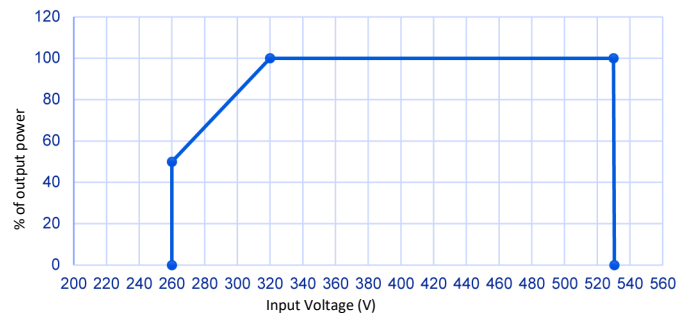

Fig.2 Input Limited Power Curve

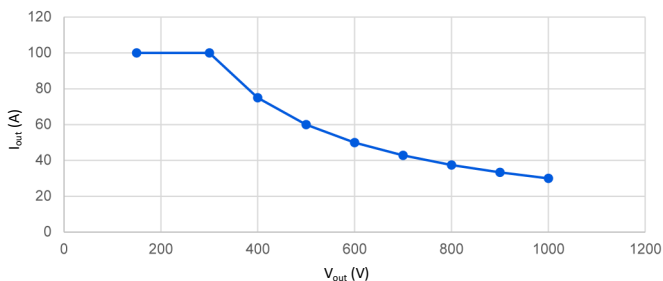

Fig.3 Output V-I Curve

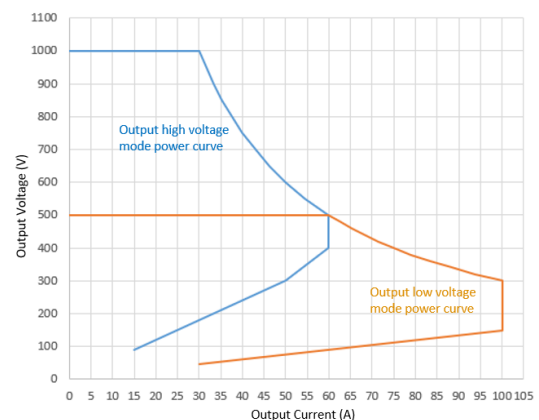

Fig.4 Output Power Curve for High Voltage Mode and Low Voltage Mode

Note 1: Power derating also occur if under some critical condition, power module's PFC stage reaches 98°C (at slope of 2.5kW/°C) or DC/DC stage reaches 106°C(at slope of 1.25kW/°C) .

Technical Specifications (continued)

Characteristic Curves (Continued)

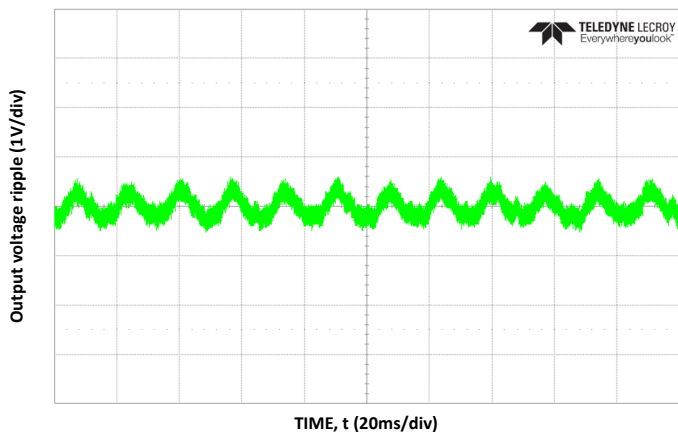

Fig.5 Output voltage ripple @Input 400Vac; Output LV 350V/Full load/ resistor load

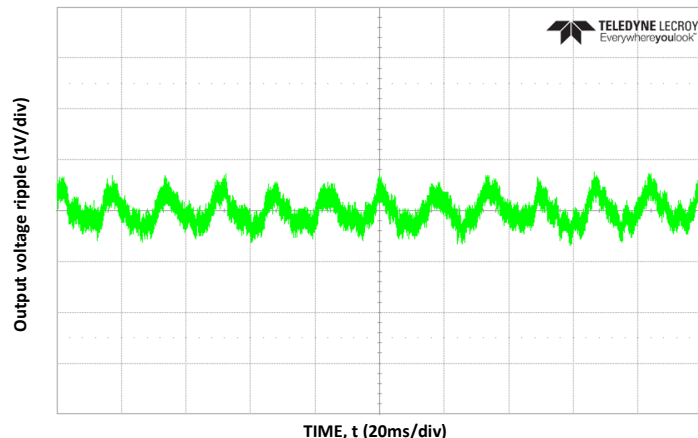

Fig.6 Output voltage ripple @Input 400Vac; Output HV 750V/Full load/ resistor load

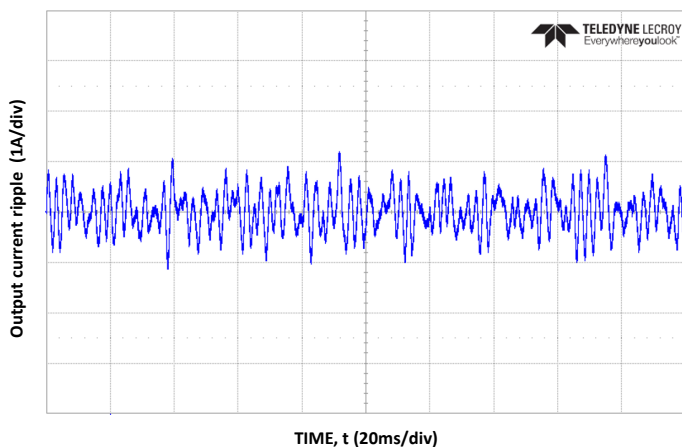

Fig.7 Output current ripple @Input 400Vac; Output LV 350V/Full load/ with 5600uF capacitor

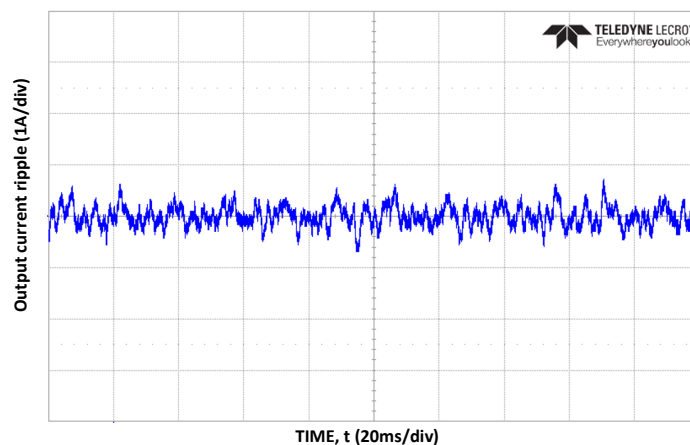

Fig.8 Output current ripple @Input 400Vac; Output HV 750V/Full load/with 5600uF capacitor

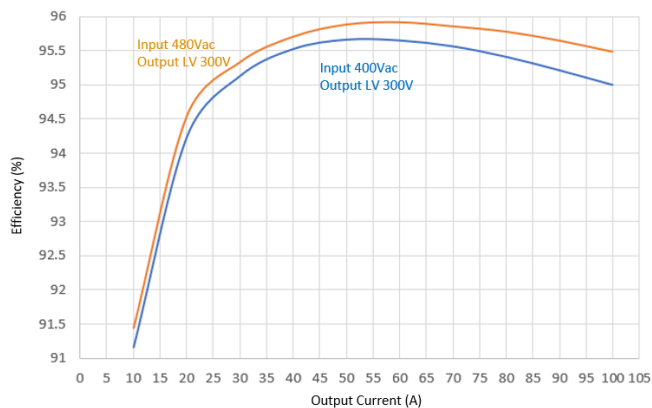

Fig.9 Rectifier Efficiency @ Output LV 300V

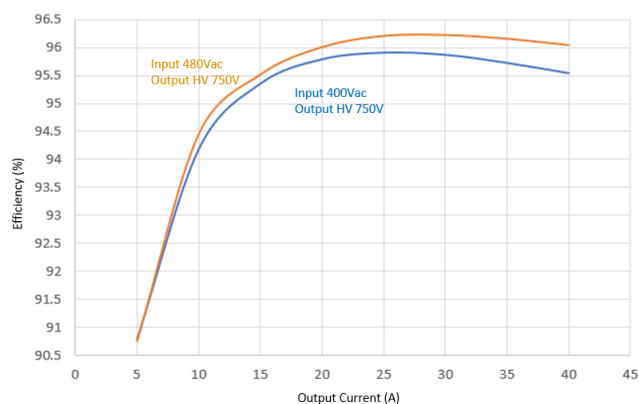

Fig.10 Rectifier Efficiency @ Output HV 750V

Technical Specifications (continued)

Characteristic Curves (Continued)

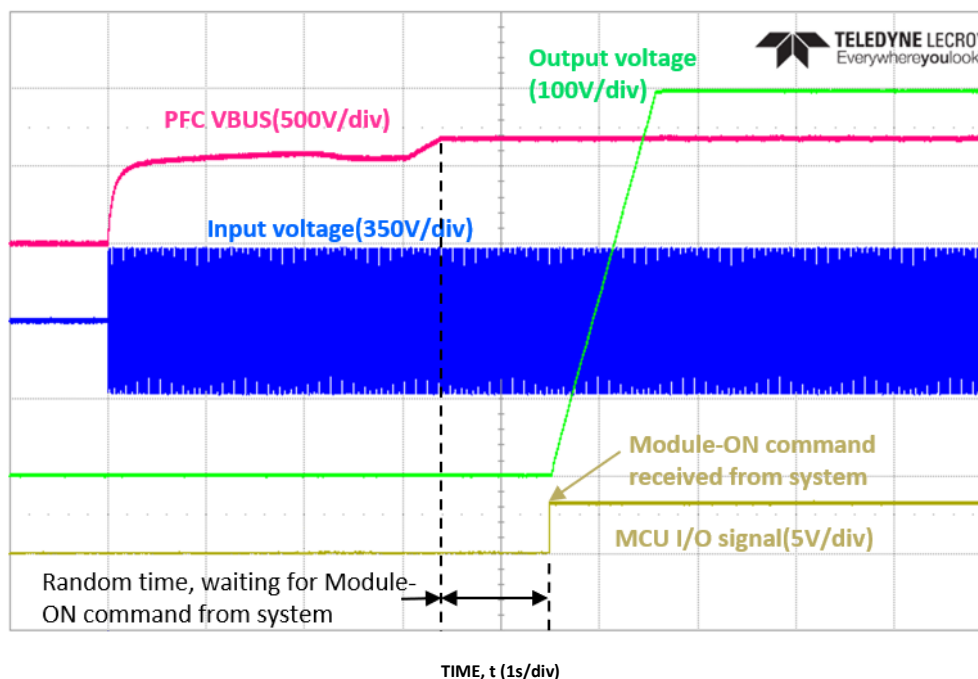

Fig.11 Power module start up @ Input 400Vac; Output HV 500V/no load

LED indicator

The warning signals of LED indicator are as below:

Lamp	Status	Condition
Green indicator	On	Normal operation
	Flashes twice in one second	Communication with monitor; DCDC OFF command is sent by monitor
Yellow indicator	On	Input AC under – voltage derating or temperature derating; Output current imbalance but still working; Module address conflict
	Off	Working normally
	Flashes twice in one second	Working in debug mode
Red indicator	On	Fan driver failure; AC input over – voltage/under – voltage; Internal over – temperature; Communication failure between PFC and DCDC; DC output over – voltage/under-voltage; CAN communication failure; AC input voltage phase loss; Over – current in DCDC primary side; Communication failure between CAN and DCDC; Output dummy load failure; Output over – current; Output relay failure; Output current imbalance
	Off	Without any failure
	Flashes twice in one second	Fan is blocked

Technical Specifications (continued)

Insulation and Safety

Parameter	Specification	Item	Standard	
Dielectric withstand voltage	Basic Isolation	AC-Enclosure	Test voltage according to IEC62477	
	Reinforced	DC-Enclosure	Test voltage according to IEC62477	
	Reinforced	AC – DC	Test voltage according to IEC62477	
	Reinforced	AC – CAN	Test voltage according to IEC62477	
	Reinforced	DC – CAN	Test voltage according to IEC62477	
Leakage current	<1.25mA (<1kHz)			
Over voltage Category			Ovc III – ac port Ovc II – dc port	According IEC62477 – 1

Safety Certification

Region	Safety standard	Marking
North America	UL2202, UL2231	
Europe	IEC60664-1: 2007 IEC/EN 61851-23 IEC61851-1	

Electro-Magnetic Compatibility

Parameter	Function	Standards	Levels	Criterion	Notes
EMI	Conducted Emission (Note2)	IEC61851-21-2 EN55032 FCC part 15 class A	CLASS A	/	AC port
	Radiated Emission (Note2)	IEC61851-21-2 EN55032 FCC part 15 class A	CLASS A	/	
	Harmonic Current Emission	IEC61000-3-2	A class equipment	/	
	Voltage fluctuation and Flicker	IEC61000-3-3	$P_{st} \leq 1.0$, $P_{it} \leq 0.65$, $d_c \leq 3\%$, $d_{max} \leq 4\%$ the value of $d(t)$ during a voltage change shall not exceed 3% for more than 200ms	/	
EMS	Immunity to Electrostatic Discharge	IEC61000-4-2	Air discharge 15kV		
			Contact discharge 8kV		
	Immunity to Radiated Electric Fields	IEC61000-4-3	20V/m	A	
	Immunity to Power Frequency Magnetic	IEC61000-4-8	100A/m	A	
	Immunity to Electrical Fast Transient	IEC61000-4-4	2KV	B	
	Immunity to surges	IEC61000-4-5	Differential mode: 2kV	B	
			Common mode : 4kV		
Immunity to Continuous Conducted Interference	IEC61000-4-6	20Vrms	A		
Immunity to Voltage Dips and short interruptions	IEC61000-4-11		B	380Vac input	

Criterion A: the output voltage should be in the regulation band during the test.

Criterion B: the power module is allowed to lose its function. Namely, it can shut off its output during the test. However, it must recover automatically after the condition is normal.

Criterion C: the power module is allowed to lose its function. Namely, it can shut off its output during the test. However, it must be able to recover after manpower's intervention.

Note 2: Conducted Emission and Radiated Emission are complied testing in system.

Technical Specifications (continued)

Mechanical features

Weight

Parameter	Min	Typ	Max	Units	Notes
Weight		14.3	15	kg	

Mechanical outline

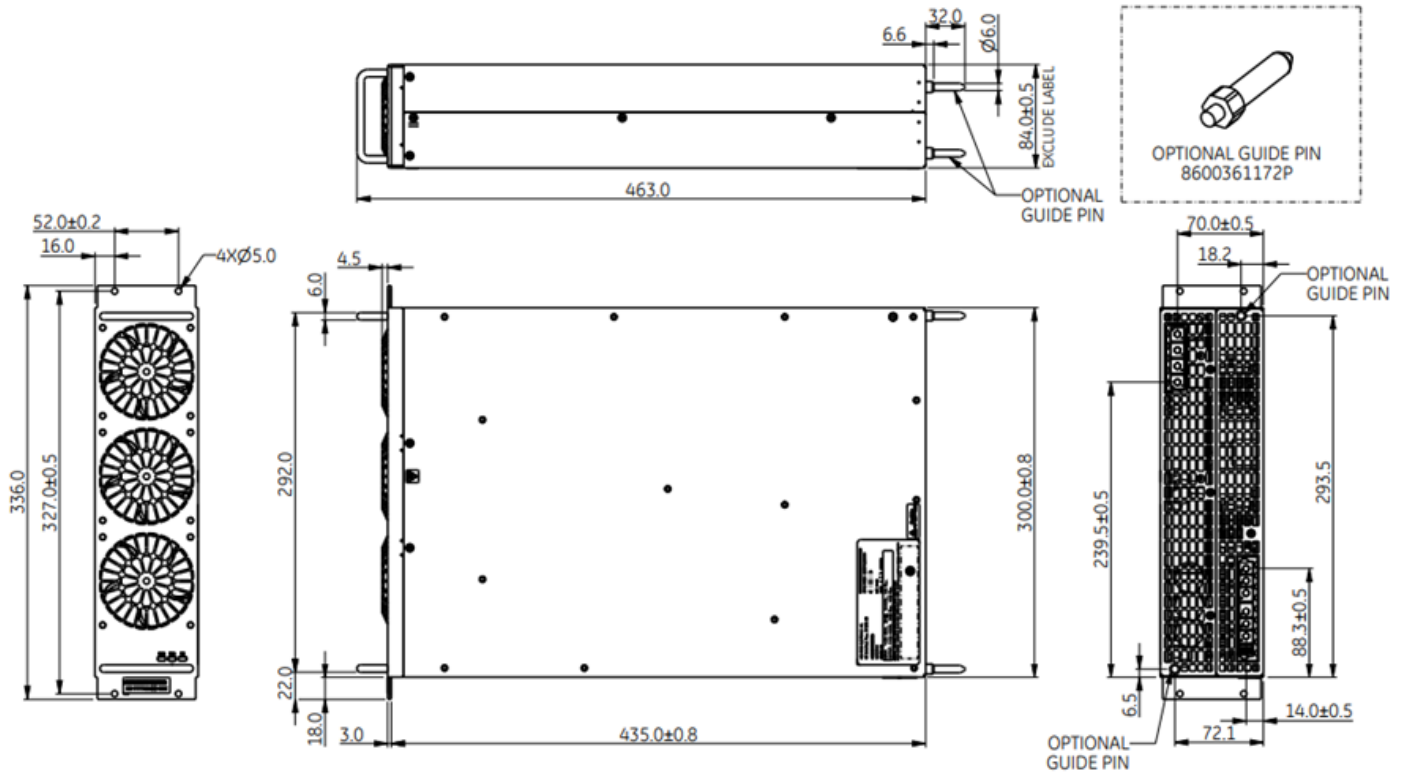

Front panel

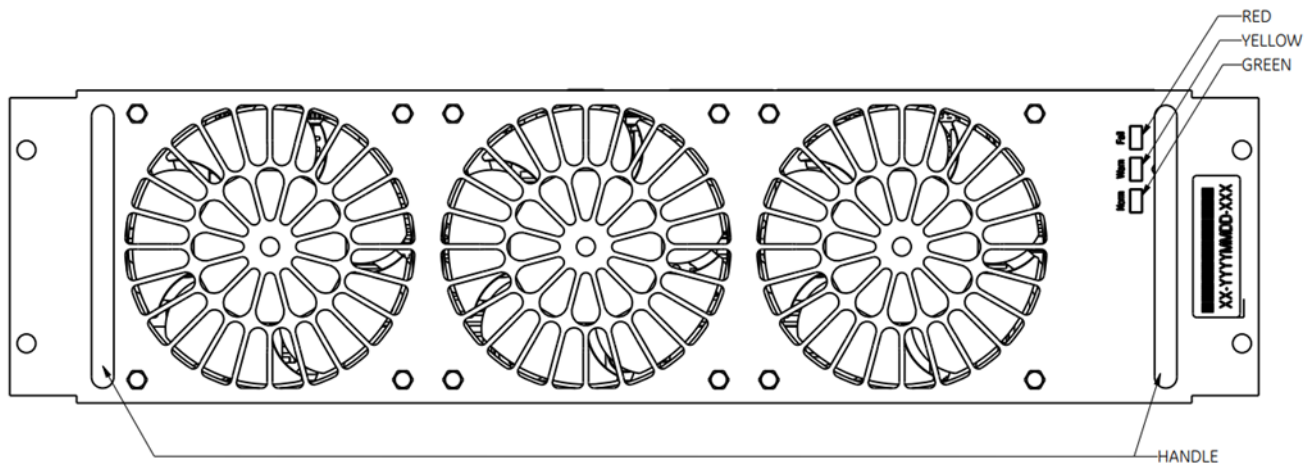

Technical Specifications (continued)

EV100H3N1K/ EV101H3N1K Connector

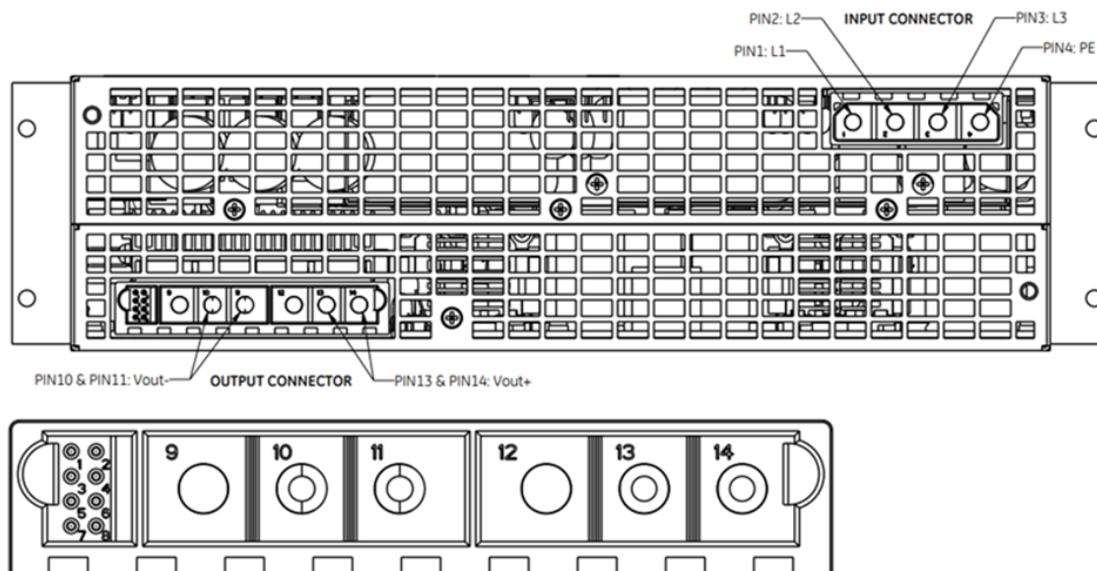

Connector Information

Connectors	Part NO.	Vendor
AC Input Connector	RPS0400008(Amphenol FCI)	RPS0415008(Amphenol FCI)
DC Output Connector	RPS1402008(Amphenol FCI)	RPS1415008(Amphenol FCI)

Pinout Information for EV100H3N1K – Without EPO

AC Input Connector		DC Output Connector	
PIN 1	L1	PIN 1	CANH
PIN 2	L2	PIN 2	CANL
PIN 3	L3	PIN 5	Address_GND
PIN 4	PE	PIN 7	Address 1
		PIN 8	Address 2
		PIN 10	VOUT -
		PIN 11	VOUT -
		PIN 13	VOUT +
		PIN 14	VOUT +

Pinout Information for EV101H3N1K – With EPO

AC Input Connector		DC Output Connector	
PIN 1	L1	PIN 1	CANH
PIN 2	L2	PIN 2	CANL
PIN 3	L3	PIN 3	EPO +
PIN 4	PE	PIN 4	EPO -
		PIN 5	Address_GND
		PIN 7	Address1
		PIN 8	Address2
		PIN 10	Vout -
		PIN 11	Vout -
		PIN 13	Vout +
		PIN 14	Vout +

The EV101H3N1K supports EPO function (Emergency Power Off) using discrete pins.

The pins are normally high, provided by auxiliary voltage from the charger. When the circuit is opened, the rectifier shuts off within 50ms.

Refer Table EPO operating sequence for EPO electrical details.

Technical Specifications (continued)

EPO Specification

Signal pins	3(+) & 4(-)
Input power consumption	<5mA
DC output	
Enable	By applying +12V ± 10%
Disable	By removing 12V or ground Output Disabled <50ms
EPO Input Isolation	
Against AC & DC	Reinforced isolation
Against Enclosure	Basic isolation

- EPO function is part of the same isolation group as the CAN interface.
- The EPO signal is reported through the alarm register.

AC input mating connector cable

The length of AC input mating connector cable is around 1500 millimetres. Refer below image.

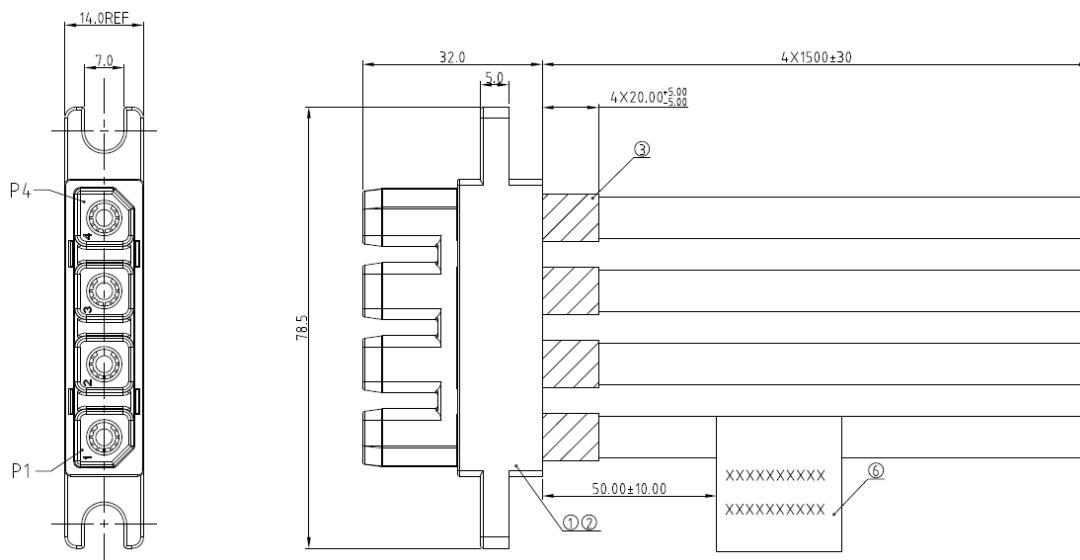
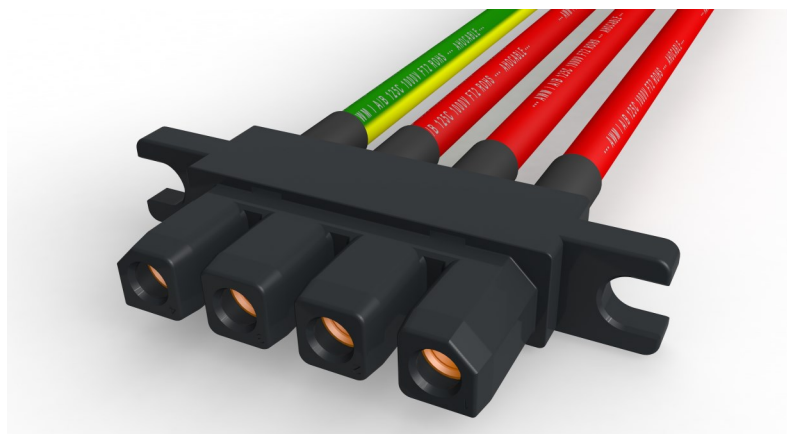

AC input mating connector

Technical Specifications (continued)

DC output mating connector cable

The length of DC output mating connector cable is around 1500 millimetres. Refer below image.

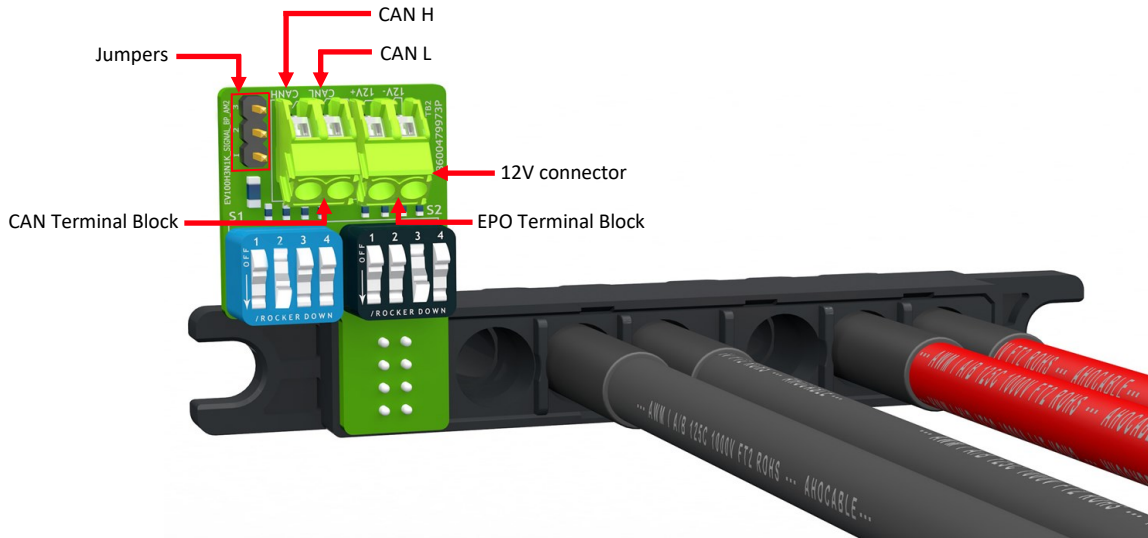

Jumper pins 1-2 Pass through



Jumper pins 2-3 120 Ohm

DC Output Cable embedded Can bus interface – back view

Note:

12V signal applied to the 12V connector powers the EPO circuit when using EV101.
12V connector is not used when connected to EV100.

Jumper Position	Function
No jumper	The function same with jumper on 1-2 pins. This photo is for show the header and pin sequence.
2 – 3 (far away from dip sw)	120Ω resistor on
1 – 2 (close to dip sw)	120Ω resistor off

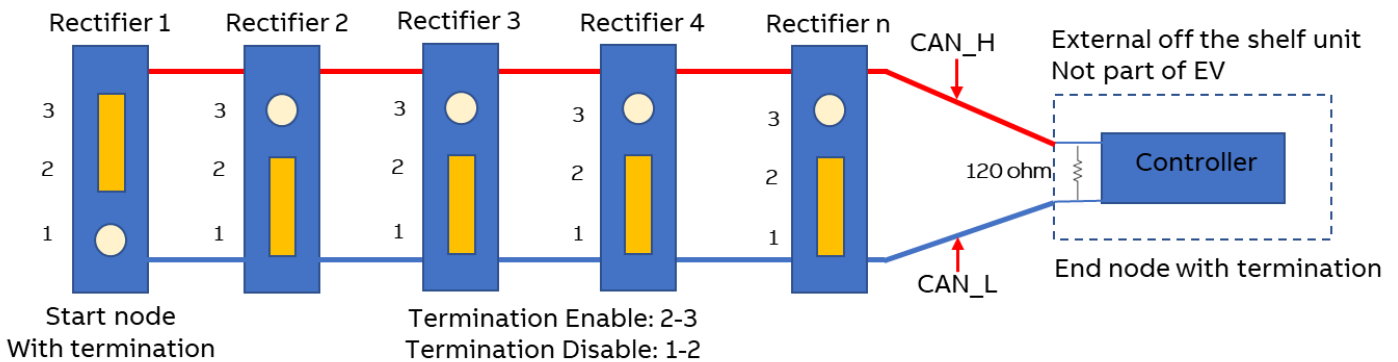

Technical Specifications (continued)

Drawing code address on Address board

Hardware address = 5* (the "ON" digital position of S2 + the "ON" digital position of S1)

Example: S1 NO.2 is "ON", S2 NO.3 is "ON"

Hardware address = 5*3+2 = 17

Note: If no any digital position is "ON", the default is zero.

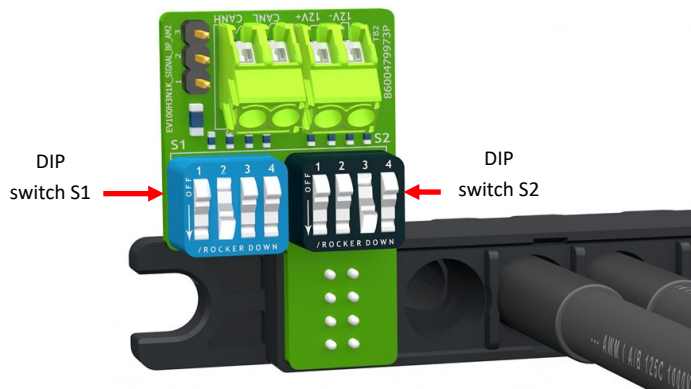

Dial code comparison table

FORMULA used: $5*S2_X + S1_Y$ >(X=1..4; Y=1..4)

Position/HW address	S1 Value	S2 Value	S1				S2			
			_1	_2	_3	_4	_1	_2	_3	_4
1	1	0	ON	OFF	OFF	OFF	OFF	OFF	OFF	OFF
2	2	0	OFF	ON	OFF	OFF	OFF	OFF	OFF	OFF
3	3	0	OFF	OFF	ON	OFF	OFF	OFF	OFF	OFF
4	4	0	OFF	OFF	OFF	ON	OFF	OFF	OFF	OFF
5	0	1	OFF	OFF	OFF	OFF	ON	OFF	OFF	OFF
6	1	1	ON	OFF	OFF	OFF	ON	OFF	OFF	OFF
7	2	1	OFF	ON	OFF	OFF	ON	OFF	OFF	OFF
8	3	1	OFF	OFF	ON	OFF	ON	OFF	OFF	OFF
9	4	1	OFF	OFF	OFF	ON	ON	OFF	OFF	OFF
10	0	2	OFF	OFF	OFF	OFF	OFF	ON	OFF	OFF
11	1	2	ON	OFF	OFF	OFF	OFF	ON	OFF	OFF
12	2	2	OFF	ON	OFF	OFF	OFF	ON	OFF	OFF
13	3	2	OFF	OFF	ON	OFF	OFF	ON	OFF	OFF
14	4	2	OFF	OFF	OFF	ON	OFF	ON	OFF	OFF
15	0	3	OFF	OFF	OFF	OFF	OFF	OFF	ON	OFF
16	1	3	ON	OFF	OFF	OFF	OFF	OFF	ON	OFF
17	2	3	OFF	ON	OFF	OFF	OFF	OFF	ON	OFF
18	3	3	OFF	OFF	ON	OFF	OFF	OFF	ON	OFF
19	4	3	OFF	OFF	OFF	ON	OFF	OFF	ON	OFF
20	0	4	OFF	OFF	OFF	OFF	OFF	OFF	OFF	ON
21	1	4	ON	OFF	OFF	OFF	OFF	OFF	OFF	ON
22	2	4	OFF	ON	OFF	OFF	OFF	OFF	OFF	ON
23	3	4	OFF	OFF	ON	OFF	OFF	OFF	OFF	ON
24	4	4	OFF	OFF	OFF	ON	OFF	OFF	OFF	ON

1. When setting the address, ensure that at most one dip switch of S1 or S2 is in the "ON" state, if more than one dip switch of S1 or S2 is in the "ON" state, hardware address calculation errors may occur.
2. If all the dial code of S1 and S2 are "OFF", which indicates invalid address.
3. The colors S1 and S2 dip switches are blue and black.

Technical Specifications (continued)

Ordering Information

Ordering Code	Description	Input Nominal Voltage	Output Voltage Range	Output Current	Temperature Range
1600293422A	EV100H3N1K 30kW DC Fast Charger Rectifier without EPO	400Vac/480Vac, 3Wire+PE	150 - 1000Vdc	100Adc max	-20°C to 70°C
1600469352A	EV101H3N1K 30kW DC Fast Charger Rectifier with EPO				

Accessories

Ordering Code	Description
4600400617P	4 POLES AC INPUT CABLE FOR EV, 6AWG
7000450144A	8S+4P DC CABLE FOR EV, 6AWG
1600449585A	CABLE KIT EV100H3N1K/EV101H3N1K CABLE SETS, contains 1 AC cable and 1DC cable
1600441222A	CANopen toolkit

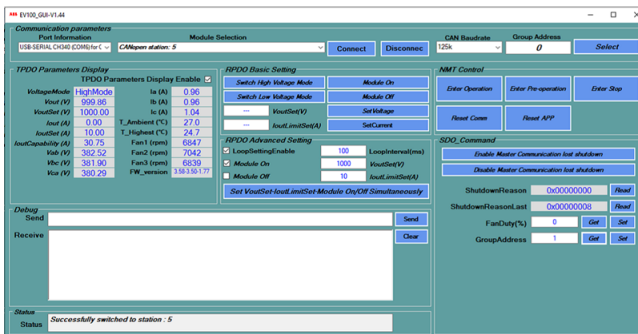

Change History (excludes grammar & clarifications)

Version	Date	Description of the change
1.0	06/15/2021	Initial Release
1.1	01/20/2022	Update dimension, output voltage slew rate; add MTBF, fan life, conformal coating, remote firmware upgradeable, salt mist;
1.2	10/06/2022	Added details for EV101H3N1K
1.3	11/18/2022	Added EPO terminal block to figures (p.11,12)
1.4	9/20/2023	Re-banded OmniOn Power

OmniOn Power
601 Shiloh Rd.
Plano, TX USA

omnionpower.com

We reserve the right to make technical changes or modify the contents of this document without prior notice. OmniOn Power does not accept any responsibility for potential errors or possible lack of information in this document.

We reserve all rights in this document and in the subject matter and illustrations contained therein. Any reproduction, disclosure to third parties or utilization of its contents – in whole or in parts – is forbidden without prior written consent of OmniOn Power. Copyright© 2023 OmniOn Power Inc. All rights reserved.