

# ECO Priority Source

## Solar Applications

### Background / purpose

ECO Priority Source is the name given to a series of rectifiers in the Infinity family which have the capability to combine alternative energy sources, such as photo-voltaic solar directly into a battery charging power system. The purpose of this application note is to give the reader a basic understanding of how these rectifiers can be used in a DC power system. Applications discussed include on and off grid.

### ECO Priority Source rectifiers

The following Infinity Rectifiers are considered part of the ECO Priority family:

#### NE050ECO48ATEZ – 48V output

#### NE100ECO24ATEZ – 24V output

As with all Infinity series rectifiers, the ECO Priority rectifiers are compatible with all single and dual voltage Infinity power systems.

ECO Priority rectifiers efficiently and easily transform solar panel output into telecom grade -48 Volt (or +24V) power. They use a straightforward provisioning method where one rectifier is assigned to manage one string of solar panels and are a good product match with the most popular mono and poly crystalline solar panels on the market today. The rectifiers, when used in this mode, perform Maximum Power Point Tracking (MPPT) for the solar panels in real time.

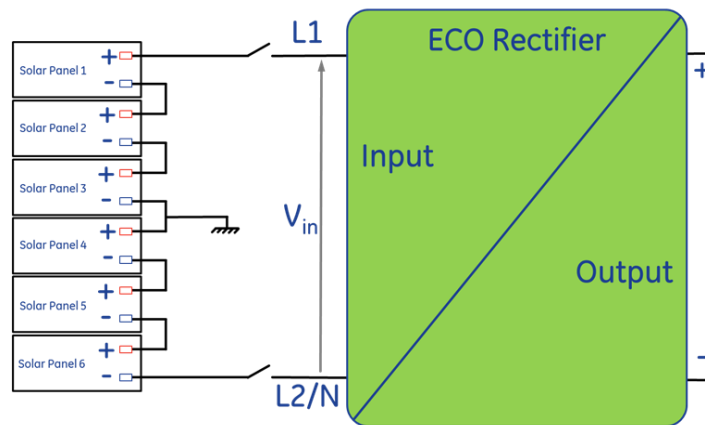

Figure 1.

The number of solar panels that can be combined into a single string is dependent upon the characteristics of the panels chosen and the environment into which they will be deployed. More on this to follow.

## Multiple energy sources

In many applications multiple energy sources are available.

One of the key advantages of ECO Priority Source is the ability to combine multiple energy sources in a single system. The rectifiers are compatible with all Infinity power systems. This means that any system with an Infinity power system is a candidate for the addition of a solar energy source.

Individual rectifiers can be fed from the utility grid, local generator, or solar panels, as shown in Figure 2.

Each rectifier puts its output onto the common battery bus, where it is used to charge batteries or supply user loads.

Rectifier priority is such that the renewable sources are used to their fullest capability before other sources (they are prioritized for primary use).

Generators are typically controlled by the system controller and only switched on when the other sources and battery reserve are insufficient.

Using this power architecture allows control and use of multiple energy sources without the need for the traditional transfer switch. Removing the need for a transfer switch increases the reliability of the system but does require additional rectifiers.

## Applications

Various combinations of grid, solar and generator power can be used in different applications. Each application has specific needs for battery performance and system capacities.

### On grid – solar supplement only.

In an “on Grid” application the electric utility would be considered the primary energy source. Batteries would be provisioned only to protect against utility outages. In normal operation the battery is maintained in float charge mode and only discharges when a utility outage occurs.

Adding a solar power source can reduce the amount of utility power used, reducing the utility bill.

Solar panels are added in strings, as shown in Figure 1, each string feeding its own rectifier.

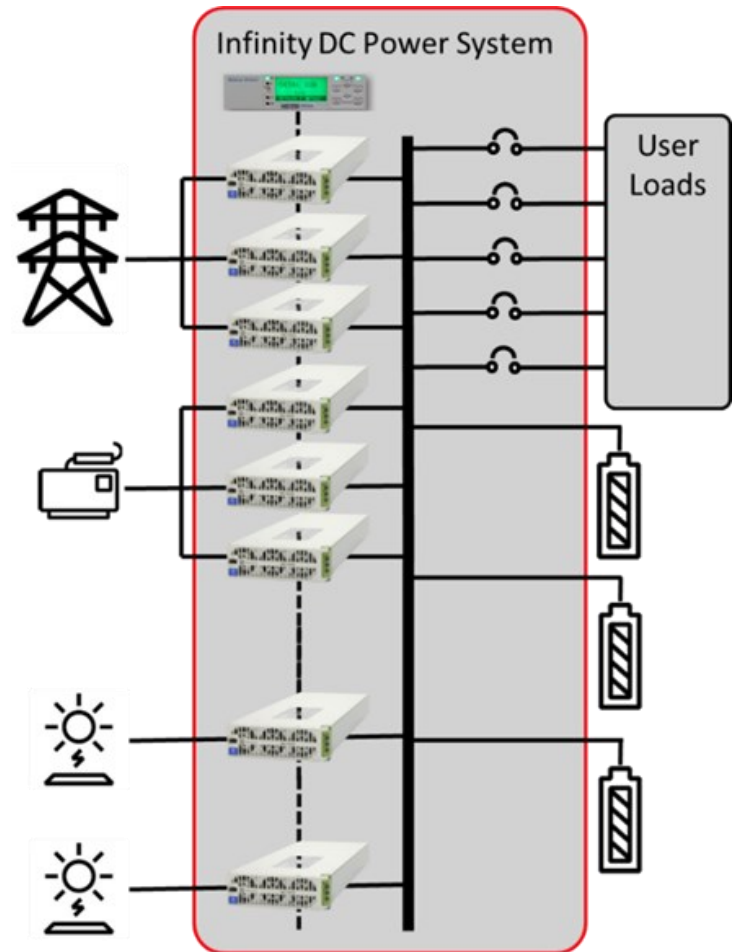

Figure 2.

Providing that the total peak power of the solar panels does not exceed the system load, then the battery operation will continue to be float charge mode. Any solar energy generated over and above the load level will be wasted, unless the batteries are sufficiently discharged to accept and store the excess.

For this reason, adding solar power to a utility powered system should not exceed the load requirements. Since the batteries only experience infrequent discharges, batteries that are optimized for float life would be used. Battery capacity provisioned would be calculated to support the longest anticipated power outage.

### Off grid – solar but no generator

In an off-grid system where solar is the **only** energy source, continuity of load operation is dependent on generating enough solar energy during the day **and** being able to store it for use at night.

Solar panel capacity must be calculated such that the solar array generates enough power to support the load **plus** enough extra to charge batteries for nighttime operation. A good rule of thumb is that the peak solar capacity should be approximately 5X the load power.

In this type of application, the batteries will charge during the day and discharge every night, so a battery should be selected that has a good cycle life characteristic.

If continuous operation is needed, battery capacity should be calculated to not only support the load overnight but also on cloudy days when they occur since there is no additional power source available. Depending on the location, this may need to be several days. Battery capacity to support the load for several days, will need additional charging capacity if the system is to be able to recharge the batteries in a reasonable amount of time after an extended time without solar energy.

The need to provision both battery capacity and solar panels to support extended outages leads to a system that is significantly bigger (and more expensive) than is strictly required to support the load on a day-to-day basis, the best solution for this is to provide a backup generator if at all possible.

### Off grid – solar with a generator

In the case of a system that is off grid, and primarily powered by the sun, a generator is a good hedge against extended periods of inclement weather, reducing the need to over provision batteries and solar panels to cope with those occurrences. The generator would typically be controlled by the Infinity power system to start and run only when the batteries reach a specified level of discharge. The generator should be equipped to accept a contact closure “start / stop” control from the power system controller.

Batteries would be expected to charge and discharge every day, so a battery with good cycle life should be selected. Capacity of the battery should be calculated to support the load for a moderate amount of time. For a fixed amount of solar capacity, more battery capacity will result in less frequent, but longer periods of generator running.

### On grid – solar primary source

It is possible to use solar energy as the primary source with the utility grid as a backup, much like a generator would be. Again, the batteries would be expected to charge during the day and discharge at night.

Batteries would be selected for a good cycle life, and utility power only used when the battery state of charge dropped below a preset threshold. The Infinity power system can control the usage of power for this type of application.

## Capacity and sizing

In most sizing calculations, the rectifier rated capacity of 2,750W is used.

## Generator

Generator sizing will depend on the type of system being supported and other energy sources available.

Generators are most frequently used as a backup for when other sources have failed. They typically must support the entire load until other sources return.

Example: A 5KW load is to be supported in an “off grid” application. When other power is not available, and the battery has been depleted, the generator must support the entire load and be able to recharge batteries. Battery recharge capacity is often calculated as 30% of the max load, so the generator capacity required will be  $5KW \times 1.3 = 6.5KW$

A 10KW generator will require about 8KW of rectifier capacity if the usual 80% derating is used. At higher elevations additional derating may be required. Consult the generator manufacturer’s instructions for derating.  $8KW / 2.75KW = 2.91$ , so 3 rectifiers would be required. If n+1 redundancy is preferred, then a fourth rectifier can be added to support this size of generator.

## Utility

Utility capacity calculations would normally be based on the expected total load, since in the absence of other sources the utility would be expected to support the total load, plus charge batteries if depleted. Battery charging capacity (recharge factor) is usually calculated as 30% of the load capacity, so total utility rectifier capacity would be  $Load \times 1.3$  and the number of rectifiers would be  $Load \times 1.3 / 2.75$  and rounded up to the next whole number. Again, if utility rectifier redundancy is required, add the number of redundant rectifiers to this calculation.

## Solar

There are several aspects to the provision of rectifiers for solar panel arrays. To assess the application we must start with several characteristics of the solar panels chosen for use.

**P<sub>max</sub>** - Nominal maximum power

**V<sub>oc</sub>** – open circuit voltage of the individual panel

**T<sub>c</sub>** - Temperature coefficient (**V<sub>oc</sub>**) of each panel

Figure 3. right, shows an excerpt from a typical solar panel data sheet, highlighting these parameters.

ELECTRICAL DATA   STC*					MECHANICAL DATA	
CS6K	260P	265P	270P	275P	Specification	Data
Nominal Max. Power (P <sub>max</sub> )	260 W	265 W	270 W	275 W	Cell Type	Poly-crystalline, 6 inch
Opt. Operating Voltage (V <sub>mp</sub> )	30.4 V	30.6 V	30.8 V	31.0 V	Cell Arrangement	60 (6×10)
Opt. Operating Current (I <sub>mp</sub> )	8.56 A	8.66 A	8.75 A	8.88 A	Dimensions	1650×992×40 mm (65.0×39.1×1.57 in)
Open Circuit Voltage (V <sub>oc</sub> )	37.5 V	37.7 V	37.9 V	38.0 V	Weight	18.2 kg (40.1 lbs)
Short Circuit Current (I <sub>sc</sub> )	9.12 A	9.23 A	9.32 A	9.45 A	Front Cover	3.2 mm tempered glass
Module Efficiency	15.88%	16.19%	16.50%	16.80%	Frame Material	Anodized aluminium alloy
Operating Temperature	-40°C ~ +85°C				J-Box	IP67, 3 diodes
Max. System Voltage	1000 V (IEC) or 1000 V (UL)				Cable	4 mm <sup>2</sup> (IEC) or 4 mm <sup>2</sup> & 12 AWG 1000 V (UL), 1000 mm (39.4 in)
Module Fire Performance	TYPE 1 (UL 1703) or CLASS C (IEC 61730)				Connector	T4-1000V or PV2 series
Max. Series Fuse Rating	15 A				Per Pallet	26 pieces, 520 kg (1146.4 lbs)
Application Classification	Class A				Per container (40' HQ)	728 pieces
Power Tolerance	0 ~ + 5 W					

\* Under Standard Test Conditions (STC) of irradiance of 1000 W/m<sup>2</sup>, spectrum AM 1.5 and cell temperature of 25°C.

ELECTRICAL DATA   NOCT*					TEMPERATURE CHARACTERISTICS	
CS6K	260P	265P	270P	275P	Specification	Data
Nominal Max. Power (P <sub>max</sub> )	189 W	192 W	196 W	199 W	Temperature Coefficient (P <sub>max</sub> )	-0.41 % / °C
Opt. Operating Voltage (V <sub>mp</sub> )	27.7 V	27.9 V	28.1 V	28.3 V	Temperature Coefficient (V <sub>oc</sub> )	-0.31 % / °C
Opt. Operating Current (I <sub>mp</sub> )	6.80 A	6.88 A	6.97 A	7.05 A	Temperature Coefficient (I <sub>sc</sub> )	0.053 % / °C
Open Circuit Voltage (V <sub>oc</sub> )	34.5 V	34.7 V	34.8 V	34.9 V	Nominal Operating Cell Temperature	45±2 °C
Short Circuit Current (I <sub>sc</sub> )	7.39 A	7.48 A	7.55 A	7.66 A		

\* Under Nominal Operating Cell Temperature (NOCT), irradiance of 800 W/m<sup>2</sup>, spectrum AM 1.5, ambient temperature 20°C, wind speed 1 m/s.

Figure 3.

The environment at the site must also be considered. As can be seen from above, the open-circuit voltage can be expected to go up as ambient temperature goes down, as indicated by the **negative** temperature coefficient (Voc).

As seen in Figure 1, the solar panels are connected in series to form an array connected to the input of a rectifier. There are two main concerns with designing a string of panels to connect to the input of an ECO Priority rectifier. The input voltage and the input power. **The highest input voltage encountered must not exceed the rectifiers rated input voltage of 310V DC. The highest input power cannot exceed 2,750W**

If the lowest temperature for the site is Tmin, then the open circuit voltage for a panel at this temperature is:

$$\mathbf{Voc\ max = Voc\ x\ (1+Tc\ x\ (25-Tmin))}$$

In the example on the data sheet excerpt, using the data for the 275W panel and a lowest temperature of -10C:

$$\mathbf{Voc\ max = 38.0\ x\ (1+0.0031x(25+10)) = 42.123\ Volts\ (per\ panel)}$$

Now we can determine how many panels (N) can be put in series without exceeding the rectifier maximum input voltage of 310V

$$\mathbf{N = 310V / Voc\ max = 310/42.13 = 7.36}$$

In this example a maximum of 7 panels can be put in a series string without exceeding the rectifier input voltage limit.

The other consideration is max power, in this case 7 panels at 275W gives a max power of 1,925W, which is less than the rectifier capacity of 2,725W.

## Battery

There are several aspects to the provision of batteries, depending on the application, as already mentioned.

In the applications where batteries get charged and discharged every day (typically the off grid applications) the battery cycle life is critical. Batteries specifically designed and optimized for solar applications with good cycle life should be chosen.

Battery capacity calculations vary depending on the battery chemistry and manufacturers recommendations.

The basic sizing calculation is for the battery to be able to support the load until the primary or backup source of energy is available. In an off-grid application this may mean supporting the load for 24 hours or more, resulting in sizeable battery installations.

## Summary

The ECO Priority Source rectifiers, when combined in an Infinity power system provide an economical, reliable and flexible way of combining renewable and traditional power sources into an integrated DC (-48V and +24V) power system for both on and off grid applications.

Solar panels can be connected directly to the power system along with other energy sources in a seamless system that optimizes the use of the available solar energy, using MPPT technology in the rectifier itself.

Further information on power systems and applications can be obtained by contacting your local OmniOn sales representative.

**OmniOn Power Inc.**

601 Shiloh Rd.  
Plano, TX USA

[omnionpower.com](http://omnionpower.com)

We reserve the right to make technical changes or modify the contents of this document without prior notice. OmniOn Power does not accept any responsibility for errors or lack of information in this document and makes no warranty with respect to and assumes no liability as a result of any use of information in this document.

We reserve all rights in this document and in the subject matter and illustrations contained therein. Any reproduction, disclosure to third parties or utilization of its contents – in whole or in parts – is forbidden without prior written consent of OmniOn Power. This document does not convey license to any patent or any intellectual property right. Copyright© 2023 OmniOn Power Inc. All rights reserved.