

CPS6000-Systems (-48V DC Power) Installation Manual

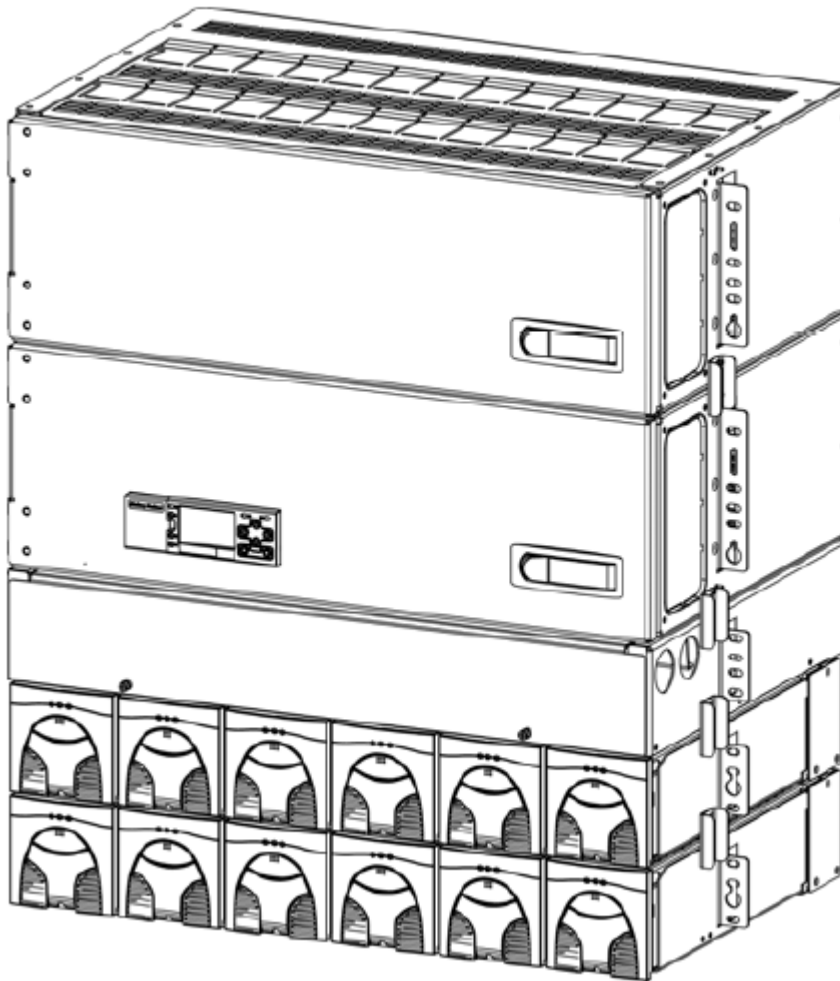

19 and 23-Inch Systems

Product Manual: CC848879683

Issue 2 March 2010

This page is intentionally left blank.

CPS6000-Systems (-48V DC Power) Installation Manual

Table of Contents

Customer Service Contacts	4
1. Safety Statements	5
2. Product Specification	9
3. Installation	13
Unpacking and Safety Precautions	13
Installation Tools	13
Torque Settings	13
Frame Mounting	13
DC Reference (CO) Ground and Chassis Ground	14
Battery String and DC Load Connections	17
Battery Monitoring Connections	23
Local Port (RS-232 / USB) Connection	26
Rectifier Installation	28
4. Initial Start-up	29
Minimum Controller Configuration	29
5. Troubleshooting	33
Rectifier Alarms	33
Troubleshooting Chart	34
6. Product Warranty	37
Appendix A: Pulsar Controller	39
User Interface Overview	39
Menu Navigation Buttons	40
System Status Display	40
Appendix B: Pulsar Wiring Connector Definitions	49
7. Revision	53

Customer Service Contacts

For customers in the United States, Canada, Puerto Rico, and the US Virgin Islands, call 1- 800-THE-1PWR (1-877-546-3243). This number is staffed from 7:00 am to 5:00 pm Central Time (zone 6), Monday through Friday, on normal business days. At other times this number contacts an answering service with on-call personnel for out of service emergencies.

Customer Training

OmniOn Power offers customer training on many Power Systems products. For information call 1-972-244-9288. This number is answered from 8:00 a.m. until 4:30 p.m., Central Time Zone (Zone 6), Monday through Friday.

Downloads and Software

To download the latest product information, product software and software upgrades, visit our web site at omnionpower.com

1. Safety Statements

CPS6000 DC Power System accepts operating AC voltage between 85V and 275V, 47-63 Hz, and produces a regulated DC Output of 42-58V. It delivers a maximum DC output of 600A at an operating temperature range of -40C to +50C. Some rectifiers are derated from 50C to 75C (2% per degree C).

HAZARDOUS VOLTAGE AND ENERGY LEVELS CAN PRODUCE SERIOUS SHOCKS AND BURNS. This power system and connected cables will have hazardous energy and voltages present. Follow all safety warnings and practices when servicing this equipment. This equipment must be installed, serviced, and operated only by authorized, qualified and trained personnel who have the necessary knowledge and practical experience with electrical equipment and who understand the hazards that can arise when working on this type of equipment. Observe all local and national electrical, environmental and workplace codes.

APPROVALS

- **System:** Underwriters Laboratories (cUR) Recognized per the U.S. and Canadian (Bi-National) Standard for Safety of Information Technology Equipment, Part 1: General Requirements, CAN/CSA C22.2 No. 60950-1-03, UL 60950-1, 1ST Edition. Considerations were also given to the safety requirements of IEC 61204-7, First Edition, Low voltage power supplies, d.c. output, Annex PS-E.
- **Rectifiers:** Underwriters Laboratories (cUR) Recognized per the U.S. and Canadian (Bi-National) Standard for Safety of Information Technology Equipment, Part 1: General Requirements, CAN/CSA C22.2 No. 60950-1-03, UL 60950-1, 1ST Edition or evaluated to EN60950-1 by an EC Notified Body, as appropriate. The CE Mark demonstrates compliance with the European Union Council Directives for Low Voltage and EMC.

INSTALLATION SITE

- Install only in restricted access areas (dedicated equipment rooms, equipment closets, or the like) in accordance with paragraphs 110.18, 110.26, and 110.27 of the U.S. National Electric Code (NEC), NFPA 70, and pursuant to applicable local codes.
- This equipment is to be used in controlled environments (an area where the humidity is maintained at levels that cannot cause condensation on the equipment, the contaminating dust is controlled, and the steady-state ambient temperature is within the range specified). This equipment must not be installed over combustible surfaces.
- CPS6000 is suitable for connection to ac utility systems where the expected level of lightning surges complies with ANSI C62.41 Category B or IEC 60664-1 Overvoltage Category II.
- A service entrance surge protector is required in applications where the installation categories cannot be classified as being compliant to either ANSI C62.41 Category B or IEC 60664-1 Overvoltage Category II.
- CPS6000 rectifiers have been tested for repeated lightning surges typically found in an Overvoltage Category III installation; however, a service entrance surge protector is recommended in cabinet applications to bring the power feeds in compliance to the installation categories above. The service entrance protection should be coordinated with the protection provided in the power modules.
- The power module provides common-mode protection via a 320V MOV in series with a 2500V gas-discharge device and differential-mode protection via a 320V MOV in series with a 3.5A fuse.

AC

- An accessible ac disconnect/protection device to remove ac power from the equipment in the event of an emergency must be provided.
- AC branch circuits to this equipment must be protected with either fuses or circuit breakers sized as required by the National Electric Code (NEC) and/or local codes. The maximum size of the over-current protector is based on the rectifier type used. Refer to Table 1 for appropriate breaker to assure rating of equipment will not exceed 80% of the value of the protector chosen.
- The equipment could be powered by multiple ac inputs. Ensure that the appropriate circuit protection device for each ac input being serviced is disconnected before servicing the equipment. Do not disconnect permanent bonding provisions unless all ac inputs are disconnected.
- High leakage currents are possible due to contribution from multiple AC input connections. Earth ground connection is essential before connecting the ac source to the shelf. This connection must be achieved by ensuring that the shelf is properly grounded as shown in the Installation Section.
- In enclosed equipment cabinets, the mounting framework must be connected directly to the cabinet ac service ground bus. For applications in huts, vaults, and central offices, the framework must be connected to the system integrated ground grid.
- CPS6000 outputs are not connected to earth. Earthing of rectifier outputs may be performed externally to the shelf at a "ground window" or "mesh ground". Reliable earthing of the DC return bus (DC reference Ground) and the chassis ground should be performed.

WIRING

- For installations in the United States, Listed compression connectors shall be used to terminate field-wired conductors, where required. For all installations, the appropriate connector is to be applied only to the correct size conductor as specified by the connector manufacturer, using only the connector manufacturer's recommended tooling or tooling approved for that connector.
- If the proper connector for the country of installation is not provided, obtain appropriate connectors and follow manufacturer's and all local requirements for proper connections. All national and local rules and regulations should be followed when making field connections.
- Insulation on field-wired conductors should be rated no less than 90° Celsius. Wire conductor size should be sized per electrical codes for 75° Celsius wire, and based on the ampacity of the associated protection device.
- Battery input cables must be dressed to avoid damage to the conductors (caused by routing around sharp edges or routing in areas where wires could get pinched) and undue stress on the connectors.
- Alarm contacts on the office alarm connector are not fused in the controller; therefore, current limiting protection for these contacts must be provided by external circuits. Maximum ratings for alarm connections are 60Vdc and 0.5 amperes. Exceeding these maximum ratings could result in fire or damage to the unit.
- Torque electrical connections to the values specified on Table 2.

DC PROTECTORS

- The D.C. outputs up to 250A are available. The DC output discharge currents shall not exceed 80% of their circuit breaker or fuse rating.
- Fuse and circuit breaker loads must not exceed 80% of the fuse and/or circuit breaker current rating.
- The short circuit current capability of the battery input to the distribution panel must not exceed 10,000A.
- Installing fuses or circuit breakers not specified for use in this shelf may result in injury to service personnel or equipment damage.
- The telecom-type (e.g., GMT type) fuses can produce sparks during interruption or clearing of a fault on a high energy circuit. Use only fuses provided with safety caps for this type of circuit. Installing telecom-type fuses not equipped with safety caps may result in injury to service personnel.

- While installing batteries, follow all safety precautions outlined in the appropriate battery product manuals.
- Batteries are connected in parallel with the output of the rectifiers. Turning off the rectifiers will not necessarily remove power from the bus. Make sure the battery power is also disconnected and/or follow safety procedures while working on any equipment that contains hazardous energy/voltage.

This page intentionally left blank.

2. Product Specification

CPS6000 is a -48V modular power system designed for 19-inch (483mm) or 23-inch (584mm) mounting frames. These systems include 1 or 2 rectifier shelves and 1 or 2 distribution panels. Rectifier shelves have either 4 slots or 6 slots providing up to 200A or 300A of DC power per shelf. AC input options include AC cords or terminal blocks. The AC cord option is 10 gage cords with a L6-30P plug each feeding two rectifier slots. Terminal block options are located either on the back of the rectifier shelf or in a front accessible ac box as shown in the figure below.

The initial distribution panel includes the Pulsar controller mounted on the door and either 20 or 26 selectable distribution positions that can be configured as either battery inputs or load outputs. Systems may be equipped with Low Voltage Battery Disconnect (LVBD), Low Voltage Load Disconnect (LVLD) or no LVD. The supplemental distribution panel has 20 or 26 additional load positions. Distribution panels are 7" (4U) high, rectifier shelves and the AC box are 3.5" (2U) high. The system depth is 14". The rear terminal block option adds an additional 3 inches of depth.

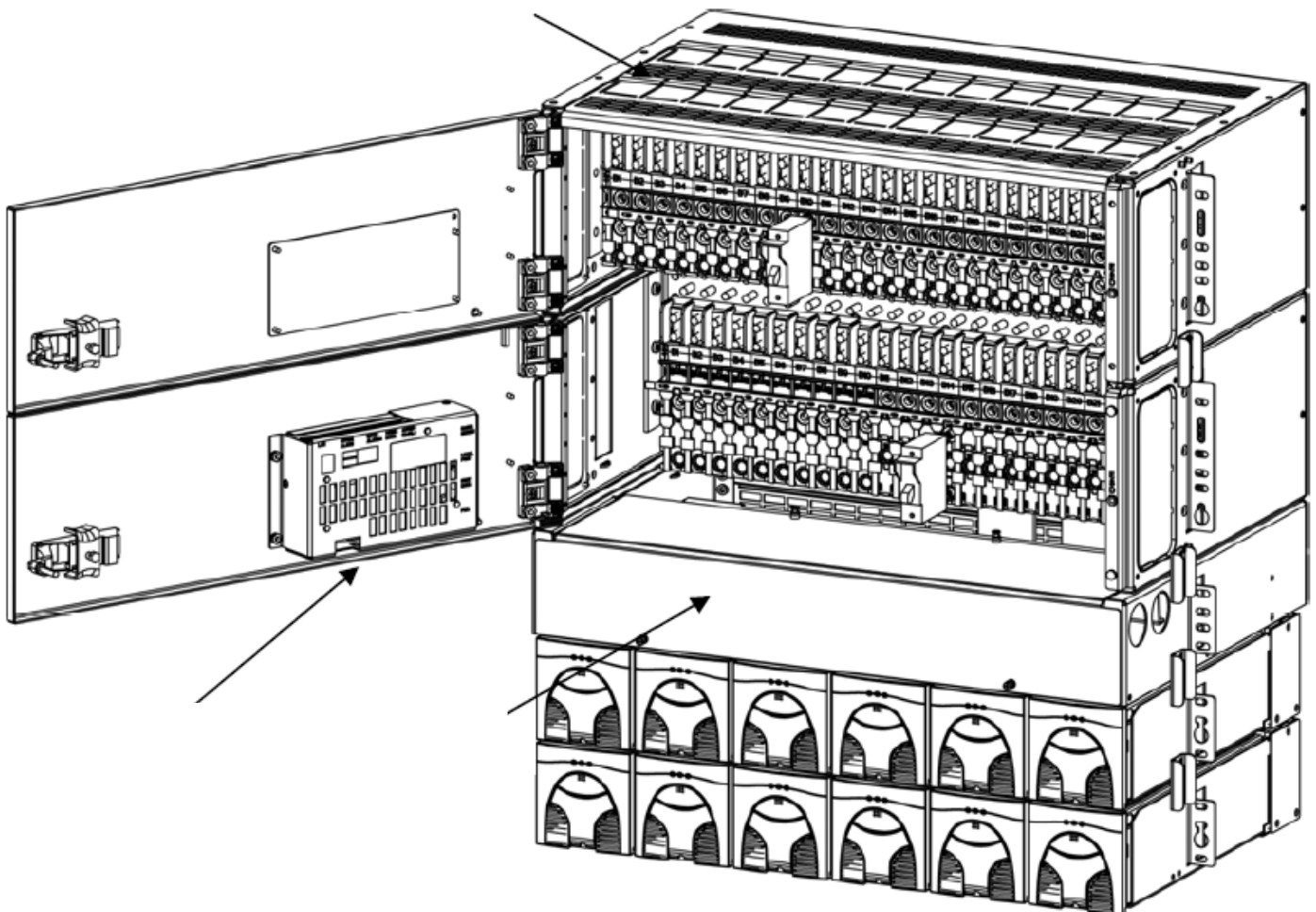

Figure 1: System shown with doors open

Rectifier Specifications

The following constant-power, vertical airflow rectifiers are available for order with this system. Values listed are per rectifier. Maximum Heat Dissipation numbers are calculated at 175VAC and maximum DC voltage and current values for the rectifier.

Model	Max DC Current (Idc)	Nominal DC Voltage (Vdc)	DC Voltage (Vdc) Range	AC Voltage (Vac) Range	Nominal AC Current (A)	Max BTU/hr	Max Watts
QS861A	15A	48	42-58	85-150	7.8	450	132
		48	42-58	150-275	4.4	445	130
QS852A	20A	48	42-58	150-275	6	454	133
QS853A	25A	48	42-58	150-275	7.4	724	212
QS862A	25/30A	48	42-58	85-150	12.0	604	177
		48	42-58	150-275	8.8	724	212
QS864A	40A	48	42-58	150-275	11.8	819	240
QS865A	50A	48	42-58	150-275	14.5	911	267

Table 1: Rectifier Specifications

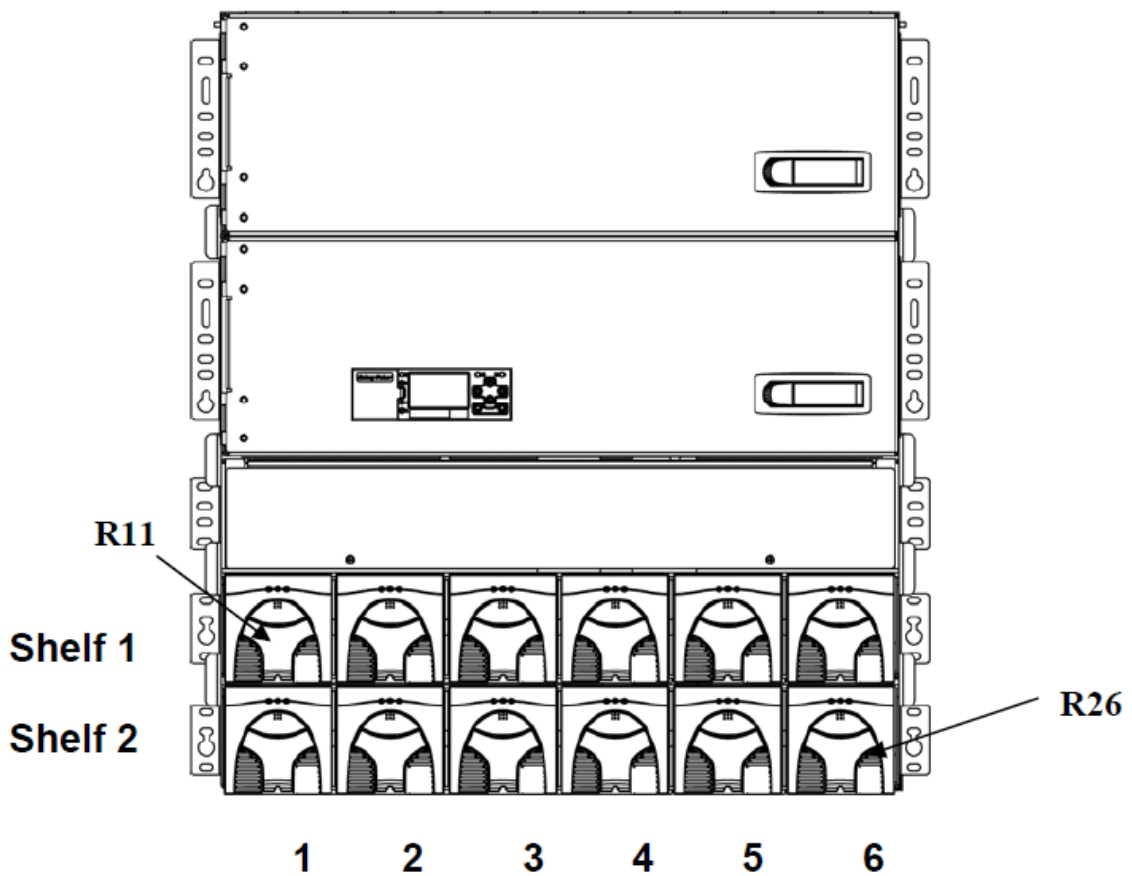

Figure 2: Typical Rectifier Numbering

DC Circuit

The following figures show the DC circuit description for the system. 19" systems have 20 bullet-style distribution positions per panel. 23" systems have 26 bullet-style distribution positions per panel. The positions in the initial distribution panel are selectable between either battery inputs or load outputs. Figure 3 shows the option where all load positions are connected to the system through a low voltage load disconnect (LVLD). Figure 4 shows the option where the battery positions are all connected to the system through a low voltage battery disconnect (LVBD). Breaker sizes up to 250A, TPS fuses to 70A and GMT fuses to 12A are available bullet modules for this system. DC Connections are made with double hole lugs on ¼-20 studs on 5/8" centers. The maximum tongue width for breaker connections is 0.68".

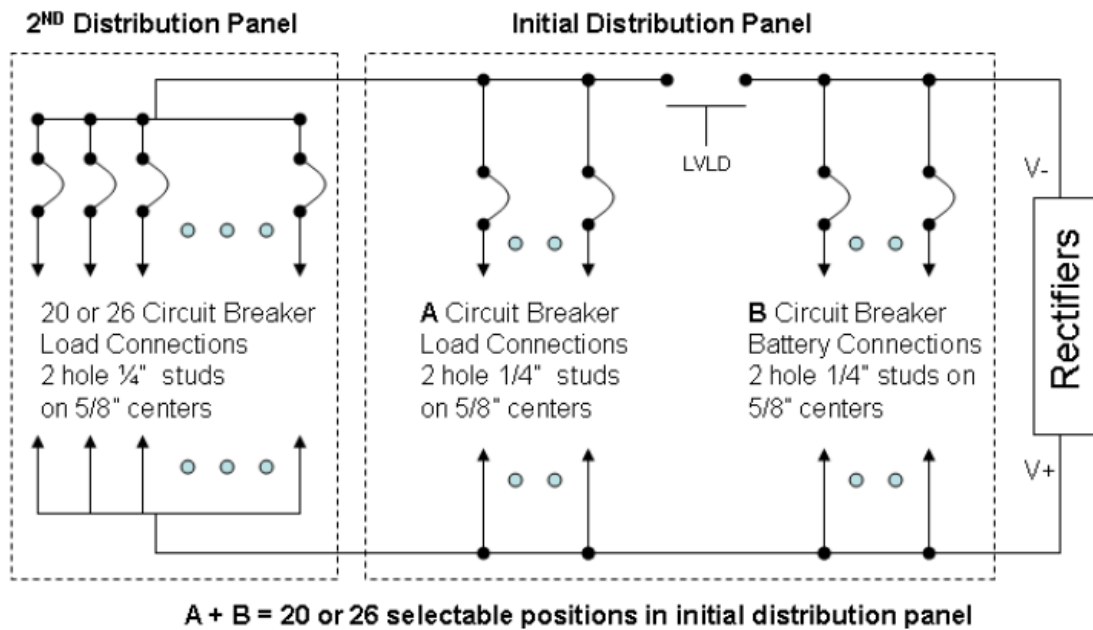

Figure 3: DC Distribution Circuit with LVLD

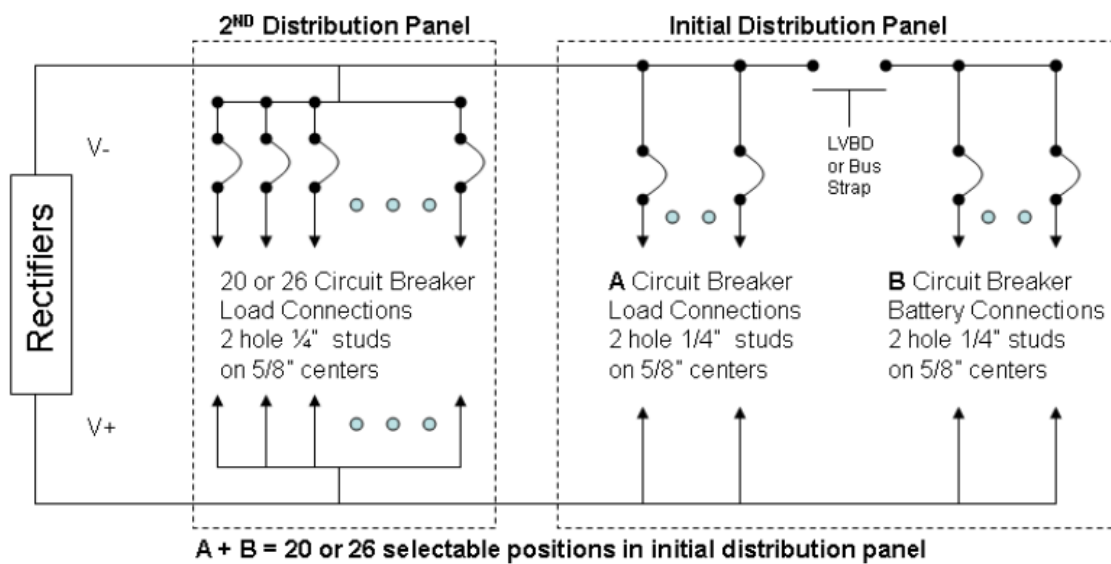

Figure 4: DC Distribution Circuit with LVBD or No LVD

This page intentionally left blank.

2. Installation

Unpacking and Safety Precautions

Before unpacking the DC power system, note any physical package damage that could indicate potential damage to the contents. After removing the components from their boxes and packing material, inspect for any shipping or other damage. Always consider personal safety. Remove all metal jewelry before beginning the installation. Care should be taken during the installation process to prevent exposure of the equipment to wire clippings. If possible, rectifiers should remain in their shipping boxes until the shelf wiring is complete.

Installation Tools

- Wire cutters and strippers
- Digital meter, +/- 0.02%
- Heat shrink gun
- Screw Drivers (#1 and #2 Phillips)
- Torque wrench (0-240 in-lb / 28 Nm)
- Cable crimpers
- 5/16", 7/16", 1/2" and 3/8" nut drivers and sockets

Torque Settings

The following table lists the recommended torque settings for all mechanical and electrical connections according to screw and nut size.

Screw or Nut Size	Torque	
	Nm	In-lbs.
4-40	1	6
6-32	1.5	12
8-32	3	22
10-32	4.25	37
12-24	5.75	50
1/4-20	7.5	65
5/16-18	15.3	135
3/8-16	27.1	240

Table 2: Torque Settings

Frame Mounting

The CPS6000 system is designed for a standard 19-inch or 23-inch wide equipment racks. The system should be installed with a minimum gap of 3/4 inch below the system to allow proper airflow. Attach the system to the frame using a minimum of 12 (six on each side)

12-24 screws included with the shelf. Weights of the systems is shown in the following table.

Systems	Weights	
	19"	23"
1 Distribution/1 Rectifier Shelf	41 lbs	54 lbs
2 Distribution/1 Rectifier Shelf	59 lbs	77 lbs
1 Distribution/2 Rectifier Shelf	55 lbs	74 lbs
2 Distribution/2 Rectifier Shelf	74 lbs	97 lbs

DC Reference (CO) Ground and Chassis Ground

Use a 1/4" diameter double-hole lug on 5/8" center (Not provided) to ground the chassis as shown in the figure below. Torque connection to 65 in-lbs. The DC reference ground is connected to the return bus as shown below. Use a 3/8" diameter double-hole lug on 1" centers (Not provided).

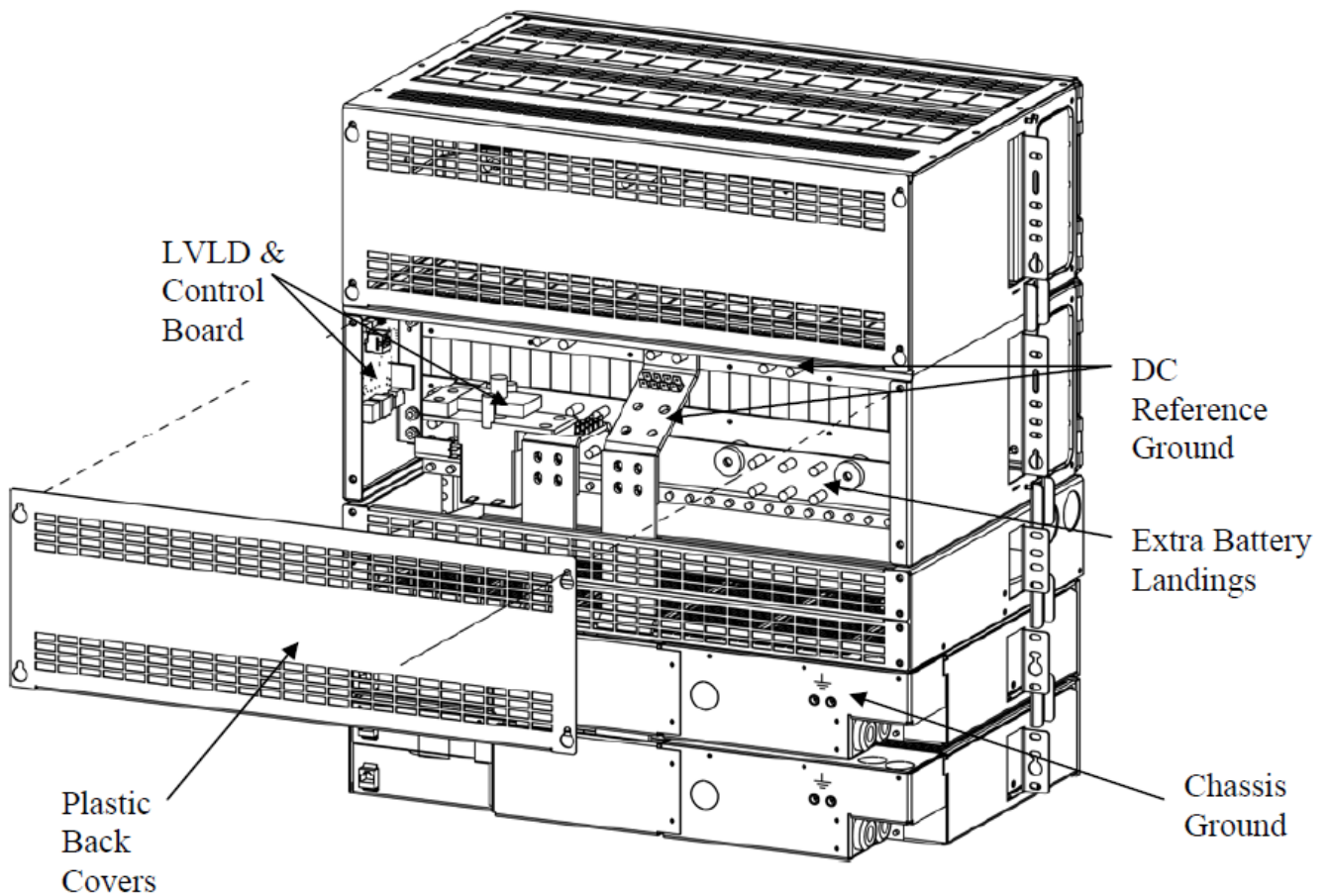

Figure 5: DC Reference Ground and Chassis Ground Connections

AC Input Connections: (3 options)

Line Cords on Rectifier Shelves (15feet long with L6-30P Plugs)

	<p>Rectifier 1 Rectifier 2 Rectifier 3 Rectifier 4 Rectifier 5 Rectifier 6</p> <p>AC Cord</p> <p>23" Shelves</p>	<p>Rectifier 1 Rectifier 2 Rectifier 3 Rectifier 4</p> <p>AC Cord</p> <p>19" Shelves</p>
--	--	--



Terminal Blocks on back of Rectifier Shelf

<p>AC Box has knockouts for 3/4" or 1" conduit.</p> <p>Two sets of conduit ground studs are located in the box. These 1/4" studs accept two-hole ground lugs on 5/8" centers.</p>	
---	--

<p>One, two or three rectifiers may be fed from a single ac feed using jumpers between the blocks. Attach jumpers as shown below. Torque screw to 10 in-lbs</p>	<p>Individual Dual Triple</p> <p>Rectifier 1 Rectifier 2 Rectifier 3 Rectifier 4 Rectifier 5 Rectifier 6</p> <p>AC</p> <p>19" Shelves</p> <p>23" Shelves</p> <p>Single Dual</p> <p>Rectifier 1 Rectifier 2 Rectifier 3 Rectifier 4</p> <p>AC</p>
---	---

<p>Snap Loose Plastic Divider With Pliers</p>		
<p>Snap loose plastic divider.</p>	<p>Install strap to connect adjacent blocks.</p>	<p>If feeding 3 positions, Attach wire to center block.</p>

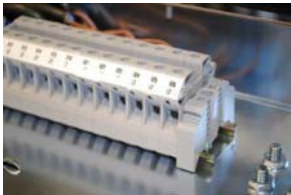
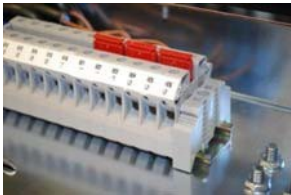
Terminal Blocks in 2U AC Box

<p>AC connection is typically 1-inch conduit per rectifier shelf connected on either the left or right side.</p> <p>Two sets of conduit ground studs are located on either side of the box. These 1/4" studs accept two-hole ground lugs on 3/4" centers.</p>	 <p>L1 connections L2 connections</p>																					
<p>One, two or three rectifiers may be fed from a single ac feed using jumpers between the blocks. Attach jumpers as shown below. Torque screw to 10 in-lbs</p>	<table border="0" style="width: 100%; text-align: center;"> <thead> <tr> <th style="width: 33%;">Individual</th> <th style="width: 33%;">Dual</th> <th style="width: 33%;">Triple</th> </tr> </thead> <tbody> <tr> <td>Rectifier 1 ← AC</td> <td>••</td> <td>••</td> </tr> <tr> <td>Rectifier 2 ← AC</td> <td>← AC</td> <td>••</td> </tr> <tr> <td>Rectifier 3 ← AC</td> <td>••</td> <td>••</td> </tr> <tr> <td>Rectifier 4 ← AC</td> <td>← AC</td> <td>••</td> </tr> <tr> <td>Rectifier 5 ← AC</td> <td>••</td> <td>← AC</td> </tr> <tr> <td>Rectifier 6 ← AC</td> <td>← AC</td> <td>••</td> </tr> </tbody> </table>	Individual	Dual	Triple	Rectifier 1 ← AC	••	••	Rectifier 2 ← AC	← AC	••	Rectifier 3 ← AC	••	••	Rectifier 4 ← AC	← AC	••	Rectifier 5 ← AC	••	← AC	Rectifier 6 ← AC	← AC	••
Individual	Dual	Triple																				
Rectifier 1 ← AC	••	••																				
Rectifier 2 ← AC	← AC	••																				
Rectifier 3 ← AC	••	••																				
Rectifier 4 ← AC	← AC	••																				
Rectifier 5 ← AC	••	← AC																				
Rectifier 6 ← AC	← AC	••																				
																						
<p style="text-align: center;">AC feed per rectifier (no jumpers)</p>	<p style="text-align: center;">AC per two rectifiers (1 jumper per 2 blocks)</p>	<p style="text-align: center;">AC per three rectifiers (2 jumpers between 3 blocks)</p>																				
		<p>If feeding 3 positions, Attachwire to center block.</p>																				

Number of Conduits	Conduit Size	Number of Rectifiers per ac feed	Min External ac Breaker	Wire Gage	Number of Wires in Conduit
1 per 4-slot rectifier shelf	¾ inch	1	20A	10	9
		2	40A	8	5
1 per 6-slot rectifier shelf	1 inch	1	20A	10	13
		2	40A	8	7
		3	60A	6	5

Table 3: AC Wire and Protectors for 50A rectifiers

Battery String and DC Load Connections

The system has up to 52 bullet-style distribution positions. All positions in the initial distribution panel are selectable between either battery inputs or load outputs. If the system is equipped with a low voltage load disconnect LVLD, then all load positions are connected to the system through the LVLD. If the system is equipped with a low voltage battery disconnect LVBD, then all battery positions are connected to the system through the LVBD. Breaker sizes up to 250A, TPS fuses to 70A and GMT fuses to 12A are available bullet modules for this system. DC Connections are made with double hole lugs on ¼-20 studs on 5/8" centers. The maximum tongue width for breaker connections is 0.68". Adapter buses are available for larger cables. Notice the color coding in the distribution. Bus bars with brown labeling are returns. Bus Bar with blue labeling are -48V. Labels are provided to identify battery verses load positions on the ID label on the front door. The initial distribution panel with the controller is rated for 600A. The supplemental (upper) panel is rated for 300A. Load distribution in system accordingly.

Note: Yellow handle or black handle Bullet-style circuit breakers can be mounted as load or battery connectors.

Yellow handle circuit breakers	Send alarm in manual off or trip position; mid-trip breakers
Black handle circuit breakers	Send alarm only in tripped position

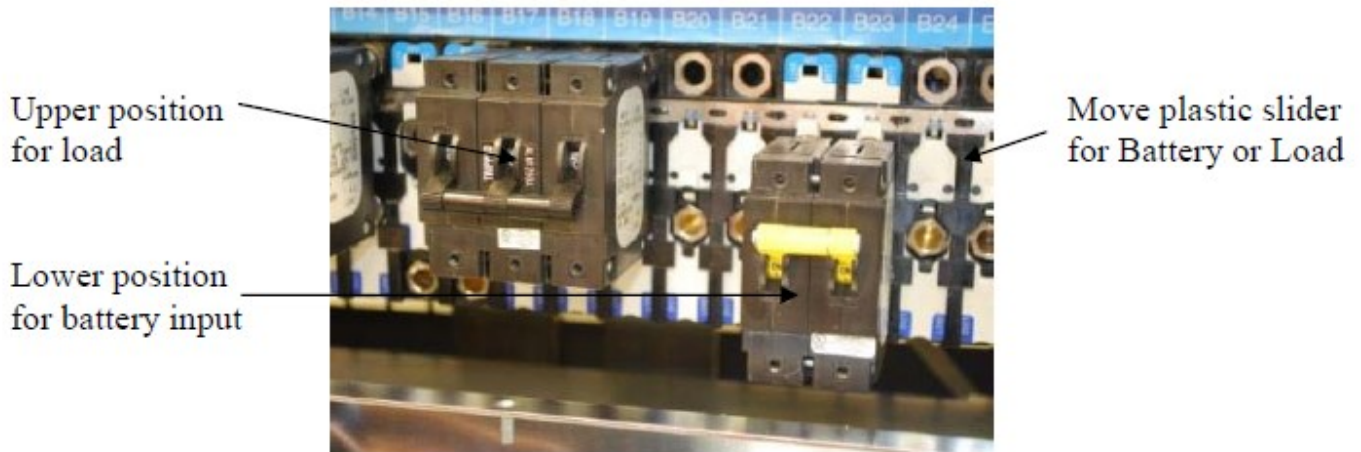

Figure 6: Selectable DC Distribution



Alarm Pin

Figure 7: Circuit Breaker Orientation



Figure 8: Distribution ID Label

Bullet Style Distribution Options



Distribution accepts Circuit Breakers, TPS Fuse Holders, and GMT Fuse Modules

Single-Pole Bullet Breakers



Connect load cables to distribution panel bus bars. The top bus bar has a brown label marked "Return Bus". Bus Landings are ¼" studs on 5/8" centers. 901352617 1/4-20 nuts are provided. Torque to 65 in-lbs. Secure the Return Load Cable, then the Load Cable. Cable size is 2 gage or less.

Verify wiring polarity at the input of the load equipment.

Insert single-pole breaker into the distribution as shown on the left side of the picture above. Verify that the alarm pin is straight before insertion.

Ensure Circuit Breakers are in the OFF position prior to installation. 1-pole breakers rated 80A and 90A must have an unused position to one side.

Leave breaker switch in the OFF position until the load equipment is ready to be energized.

Single-Pole Bullet TPS Fuse Holders



Connect load cables to distribution panel bus bars. The top bus bar has a brown label marked "Return Bus". Bus Landings are ¼" studs on 5/8" centers. 901352617 1/4-20 nuts are provided. Torque to 65 in-lbs using 7/16" socket. Secure the Return Load Cable, then the Load Cable. Cable size is 2 AWG or less.

Verify wiring polarity at the input of the load equipment.

Insert single-pole TPS fuseholder into the distribution as shown on the left side of the picture above. Verify that the alarm pin is straight before insertion.

Ensure no TPS fuse or GMT Alarm Fuse is installed in the Fuse Holder Head.

Do not install load fuse and alarm fuse until the load equipment is ready to be energized.



Two-Pole Bullet Breakers



Two-pole breakers require a cc848756916 adapter bus to strap two load buses together. This adapter bus has ¼" studs on 5/8" centers and allows load lug landings up to 2/0 cable. The return bus does not require the adapter bus unless 1/0 or 2/0 cable is used and the overlap of the lug tongue interferes with the adjacent lug. Secure Two-pole adapter busses to the distribution Load busses and return bus (if desired) as shown in the picture above using 901352617 1/4-20 nuts provided. Torque to 65 in-lbs using 7/16" socket.



Connect load cables to the adapter bus. The top bus bar has a brown label marked "Return Bus". 901352617 1/4-20 nuts are provided. Torque to 65 in-lbs using 7/16" socket. Secure the Return Load Cable, then the Load Cable. Cable size is 2/0 AWG or less.

	Verify wiring polarity at the input of the load equipment.
	Insert two-pole breaker into the distribution as shown in the center of the picture above. Verify that the alarm pin is straight before insertion. Ensure Circuit Breakers are in the OFF position prior to installation.
	Leave breaker switch in the OFF position until the load equipment is ready to be energized.
Three-Pole Bullet Breakers:	
	Secure three-pole adapter busses to the distribution Load and Return busses with provided(901352617) 1/4-20 nuts. Use 7/16" socket. Torque to 65 in-lbs. Notice that the return busadapter is turned backwards in the distribution picture above. This requires that the load return lug be connected to the adapter first, then attached to the return bus.
	<p>Secure Load and Return Cable connections to the adapter bus with provided hardware (per cable):</p> <ul style="list-style-type: none"> (2) 841064777 3/8-16 nut (2) 801829607 3/8-inch lockwasher (2) 802841635 3/8-inch flatwasher Use 9/16" socket. Torque to 240 in-lbs. <p>Terminal lugs should be 3/8 inch holes on 1 inch centers.</p> <p>Verify wiring polarity at the input of the load equipment.</p> <p>Insert three-pole breaker into the distribution as shown in the distribution picture above. Verify that the alarm pin is straight before insertion. Ensure Circuit Breakers are in the OFF position prior to installation.</p> <p>Leave breaker switch in the OFF position until the load equipment is ready to be energized.</p>
GMT Bullet Fuse Modules	
	<p>The return bus on the GMT module has three mounting positions. Remove two 10-32 nuts and move this bus to the center set of holes. Reinstall the two 10-32 nuts. This allows the return bus connection to mate with the distribution return bus on the distribution panel.</p> <p>Insert GMT fuse module into the distribution as shown in distribution picture above. Verify that the alarm pin is straight before insertion. Using two 901352617 1/4-20 nuts provided, secure the return bus using a 7/16" socket. Torque to 65 in-lbs.</p> <p>Strip load wire 3/8" and secure in the GMT module terminal block. Use #1 slot screwdriver. Torque to 13 in-lbs.</p> <p>Dress and wire tie with service loop to provide strain relief.</p> <p>Verify wiring polarity at the input of the load equipment.</p> <p>Do not install load fuses until the load equipment is ready to be energized.</p>
Note: GMT Module has Current Capacity of 58A. Maximum fuse size is 12A	

Controller Wiring

Refer to Appendix A for Controller Operation information. Refer to Appendix B for the pin assignment for controller connectors.

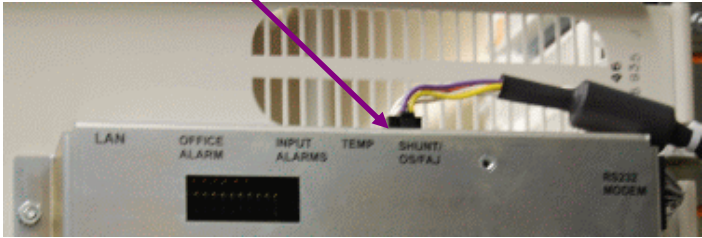
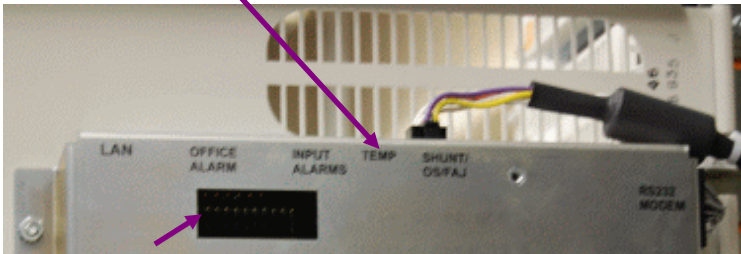
Step	Action																																																																															
1.	ESD Ground Connector is located on the lowerright corner of the distribution section for connection of a wrist strap.																																																																															
2.	<p>J1-Plant Interface Connection: Factory Installed. Violet Wire is “Open String (OS) signal from battery breakers. The Yellow Wire is -48FAJ from load breakers.</p> 																																																																															
3.	<p>J2-Voltage/Temperature (VT) Probe Connection: RJ-45 connection from Voltage/Thermal (VT) probes from mid-string battery post of battery.</p>  <p>If using ES771 Voltage Module, Verify the 1-Wire serial bus reference: The ES771 modules must be referenced to the most negative potential of the DC bus. This reference is achieved by the proper setting of Jumper 11 next to the relay configuration jumpers. Following are the appropriate settings for negative and positive power plants.</p> <p>For +24V systems with Negative Grounded batteries</p> <table border="0" data-bbox="305 1633 792 1759"> <tr> <td></td> <td>11</td> <td>10</td> <td>9</td> <td>8</td> <td>7</td> <td>6</td> <td>5</td> <td>4</td> <td>3</td> <td>2</td> <td>1</td> <td></td> </tr> <tr> <td>+24V factory default</td> <td><input checked="" type="checkbox"/></td> <td><input type="checkbox"/></td> <td><input type="checkbox"/></td> <td><input type="checkbox"/></td> <td><input type="checkbox"/></td> <td><input type="checkbox"/></td> <td><input type="checkbox"/></td> <td><input type="checkbox"/></td> <td><input type="checkbox"/></td> <td><input type="checkbox"/></td> <td><input type="checkbox"/></td> <td>Pin 1</td> </tr> <tr> <td>1-Wire Ref</td> <td><input type="checkbox"/></td> <td><input type="checkbox"/></td> <td><input type="checkbox"/></td> <td><input type="checkbox"/></td> <td><input type="checkbox"/></td> <td><input type="checkbox"/></td> <td><input type="checkbox"/></td> <td><input type="checkbox"/></td> <td><input type="checkbox"/></td> <td><input type="checkbox"/></td> <td><input type="checkbox"/></td> <td></td> </tr> </table> <p>For -48V systems with Positive Grounded batteries</p> <table border="0" data-bbox="305 1780 792 1927"> <tr> <td></td> <td>11</td> <td>10</td> <td>9</td> <td>8</td> <td>7</td> <td>6</td> <td>5</td> <td>4</td> <td>3</td> <td>2</td> <td>1</td> <td></td> </tr> <tr> <td>-48V</td> <td><input checked="" type="checkbox"/></td> <td><input type="checkbox"/></td> <td><input type="checkbox"/></td> <td><input type="checkbox"/></td> <td><input type="checkbox"/></td> <td><input type="checkbox"/></td> <td><input type="checkbox"/></td> <td><input type="checkbox"/></td> <td><input type="checkbox"/></td> <td><input type="checkbox"/></td> <td><input type="checkbox"/></td> <td>Pin 1</td> </tr> <tr> <td>1-Wire Ref</td> <td><input type="checkbox"/></td> <td><input type="checkbox"/></td> <td><input type="checkbox"/></td> <td><input type="checkbox"/></td> <td><input type="checkbox"/></td> <td><input type="checkbox"/></td> <td><input type="checkbox"/></td> <td><input type="checkbox"/></td> <td><input type="checkbox"/></td> <td><input type="checkbox"/></td> <td><input type="checkbox"/></td> <td></td> </tr> </table>			11	10	9	8	7	6	5	4	3	2	1		+24V factory default	<input checked="" type="checkbox"/>	<input type="checkbox"/>	<input type="checkbox"/>	<input type="checkbox"/>	<input type="checkbox"/>	<input type="checkbox"/>	<input type="checkbox"/>	<input type="checkbox"/>	<input type="checkbox"/>	<input type="checkbox"/>	<input type="checkbox"/>	Pin 1	1-Wire Ref	<input type="checkbox"/>	<input type="checkbox"/>	<input type="checkbox"/>	<input type="checkbox"/>	<input type="checkbox"/>	<input type="checkbox"/>	<input type="checkbox"/>	<input type="checkbox"/>	<input type="checkbox"/>	<input type="checkbox"/>	<input type="checkbox"/>			11	10	9	8	7	6	5	4	3	2	1		-48V	<input checked="" type="checkbox"/>	<input type="checkbox"/>	<input type="checkbox"/>	<input type="checkbox"/>	<input type="checkbox"/>	<input type="checkbox"/>	<input type="checkbox"/>	<input type="checkbox"/>	<input type="checkbox"/>	<input type="checkbox"/>	<input type="checkbox"/>	Pin 1	1-Wire Ref	<input type="checkbox"/>	<input type="checkbox"/>	<input type="checkbox"/>	<input type="checkbox"/>	<input type="checkbox"/>	<input type="checkbox"/>	<input type="checkbox"/>	<input type="checkbox"/>	<input type="checkbox"/>	<input type="checkbox"/>	<input type="checkbox"/>	
	11	10	9	8	7	6	5	4	3	2	1																																																																					
+24V factory default	<input checked="" type="checkbox"/>	<input type="checkbox"/>	<input type="checkbox"/>	<input type="checkbox"/>	<input type="checkbox"/>	<input type="checkbox"/>	<input type="checkbox"/>	<input type="checkbox"/>	<input type="checkbox"/>	<input type="checkbox"/>	<input type="checkbox"/>	Pin 1																																																																				
1-Wire Ref	<input type="checkbox"/>	<input type="checkbox"/>	<input type="checkbox"/>	<input type="checkbox"/>	<input type="checkbox"/>	<input type="checkbox"/>	<input type="checkbox"/>	<input type="checkbox"/>	<input type="checkbox"/>	<input type="checkbox"/>	<input type="checkbox"/>																																																																					
	11	10	9	8	7	6	5	4	3	2	1																																																																					
-48V	<input checked="" type="checkbox"/>	<input type="checkbox"/>	<input type="checkbox"/>	<input type="checkbox"/>	<input type="checkbox"/>	<input type="checkbox"/>	<input type="checkbox"/>	<input type="checkbox"/>	<input type="checkbox"/>	<input type="checkbox"/>	<input type="checkbox"/>	Pin 1																																																																				
1-Wire Ref	<input type="checkbox"/>	<input type="checkbox"/>	<input type="checkbox"/>	<input type="checkbox"/>	<input type="checkbox"/>	<input type="checkbox"/>	<input type="checkbox"/>	<input type="checkbox"/>	<input type="checkbox"/>	<input type="checkbox"/>	<input type="checkbox"/>																																																																					

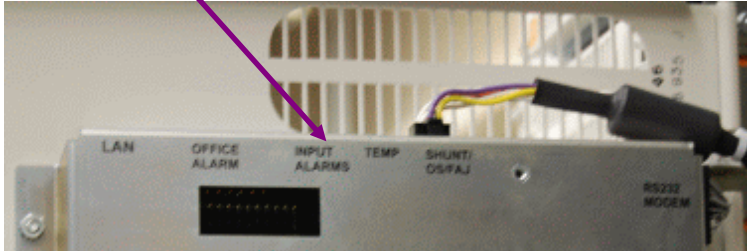
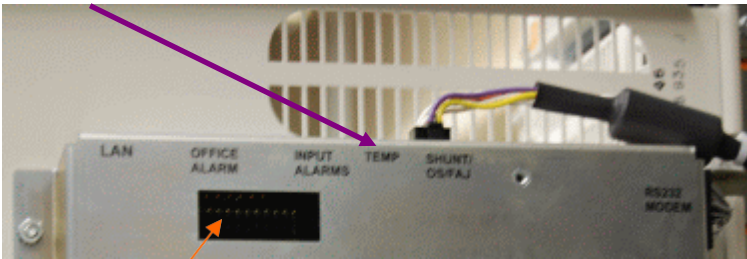
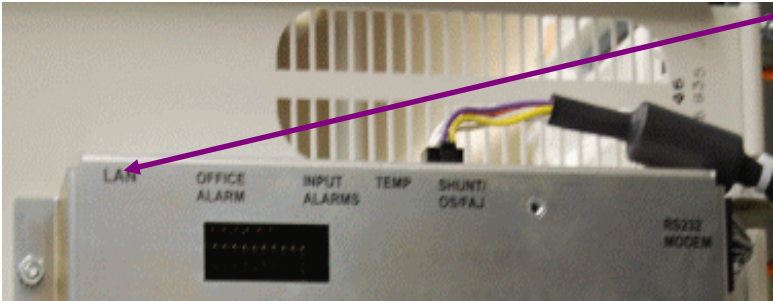
Step	Action
4.	<p>J3-Input Alarm Connection: Insert the terminated end of the Alarm Input wireset(CC848817651or similar) into the Input Alarms connector.</p> 
5.	<p>J4-Output Alarm Connection: Insert the terminated end of the Office Alarm Output wireset (CC848817635 or similar) into the Office Alarm connector on the top edge of the controller.</p> <p>Configure alarm relays to “Open” or “Close” on alarm as required: These jumpers set the ten Form-C alarm outputs on the connector J4. Carefully move each of respective configuration jumpers to the desired contact type: “Open On Alarm” or “Closed OnAlarm” position as required per site instructions.</p> <p>Pin 1</p> 
6.	<p>J5- Local Area Network (LAN) Connection: Insert a 10/100Base-T CAT-5 LAN wireset into the LAN connector on the top edge of the controller.</p> 
7.	Open the door to the widest position.
8.	Dress the field wiring using the tie points next to the upper hinge and out the side of the cabinet.
9.	Check to make sure the door can open and close without straining the connectors.

Battery Monitoring Connections

QS873A VT-Probes are used to measure battery temperature for slope thermal compensation, and to measure battery voltage for battery voltage imbalance detection when the Voltage Monitoring Module 108958422 card is used. There is a maximum 16 probes. The highest temperature measured from all installed VT probes is used by the controller for slope thermal compensation. The number of probes per string is to be defined by the user. Typical installation requires 1 thermal probe in the middle of each string of batteries as shown in the following figures.

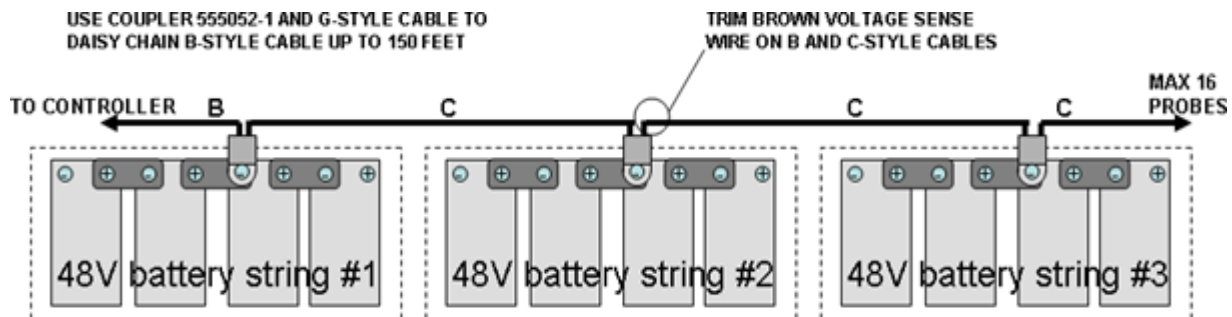

Figure 9: VT-Probe Connections for Monitoring Battery Temperature

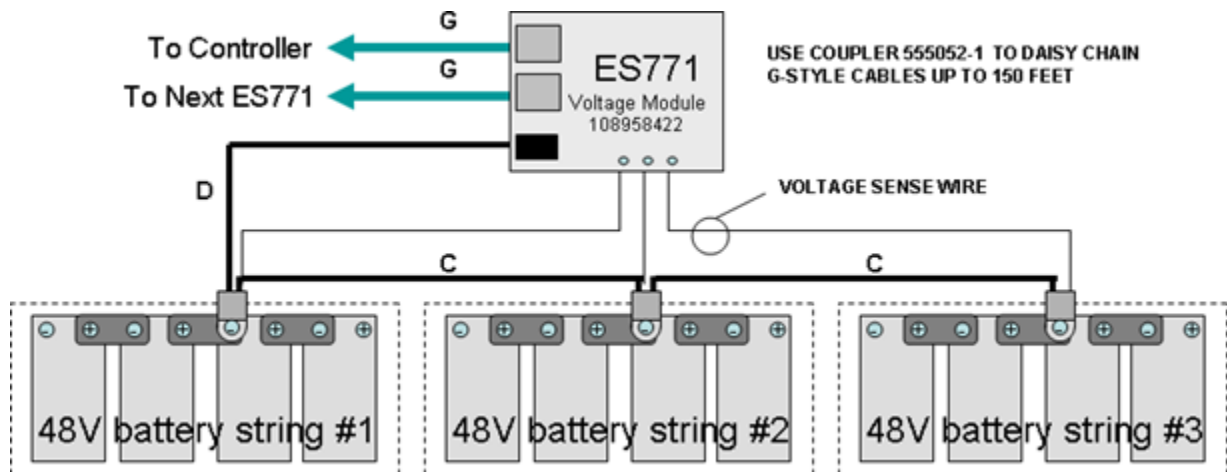

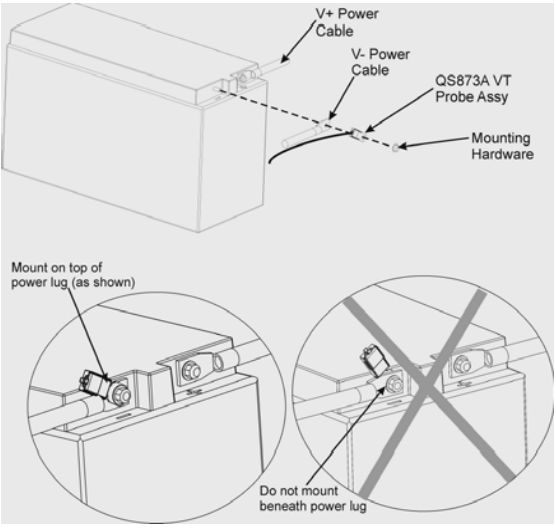

Figure 10: VT-Probe Connections for Monitoring Battery Temperature and Voltage

VT Probes Installation for Monitoring Battery Temperature Only (Refer to Figure 9)

Step	Action
1.	Insert the RJ-45 end of a B-style cable into the J2 Connector on the controller.
2.	If present, cut the brown voltage sense wire on the B-style cable at the 3-pin connector.
3.	Insert the 3-pin connector end into the receptacle on the 1st VT-Probe. 
4.	Place the first probe to the battery post (as shown in the picture). Note: Probes are typically installed one per string, located in the center of the string. Note: Do not mount the VT-Probe under a lug or battery strap. The probe mounts on top of the lug or battery strap. Note: Probes can be mounted prior to making the connections at the controller. The controller will automatically recognize the VT-probe. 
5.	Verify the number of probes (1) registered with the controller with command: MENU > STATUS > BATTERIES > TEMP PROBES PRESENT.
6.	Connect C-style cables to the 2-position receptacle of the first probe and to the 3-position receptacle of another probe. cut the brown voltage sense wire at the 3-pin connector
7.	Verify the number of probes (2) registered with the controller with command: MENU > STATUS > BATTERIES > TEMP PROBES PRESENT.
8.	Repeat Steps 6-7 for each probe until all probes are installed.
9.	When all probes are installed, verify they are connected and operating with command: MENU > STATUS > BATTERIES > TEMP PROBES PRESENT.

The controller is now able to make thermal measurements in performing Slope Thermal Compensation (STC) and battery high temperature disconnect. To enable or verify that STC is active go to **MENU > CONFIGURATION > BATTERIES > BATTERY TEMP MANAGEMNT** and select **TEMPERATURE COMP** and verify that the feature Temperature Comp is Enabled. If not, configure and save it appropriately. Additional parameters associated with slope thermal compensation may be set on the controller to customize this feature.

VT Probes Installation for Monitoring Battery Temperature and Voltage (Refer to Figure 10)

Step	Action
1.	Insert one RJ-45 end of the G-style cable into the J2 Connector on the controller and the other end to the first ES771A Remote Voltage Monitor module. Set address switch to 01 on ES771A.
2.	Follow the steps for installing a probe described in the previous section to attach a VT probe to the negative post located at the center of the string. Do not cut the brown wire.
3.	Dress and attach the snap fit connector on the brown wire to the appropriate snap fit pin on the ES771A (J1-J3).
4.	Verify the number of modules (1) registered with the controller with command: MENU > STATUS > BATTERIES > NUM MID-STRING V. Note: Modules will only be recognized when there is actual potential applied through the VTprobe to the ES771 module.
5.	If required, connect another ES771A by connecting an additional G-style cable into RJ-45 receptacles on both modules. Set address switch to 02 on ES771A.
6.	Verify the number of modules (2) registered with the controller with command: MENU > STATUS > BATTERIES > NUM MID-STRING V.
7.	Repeat Steps 5-6 until all required ES771A modules are installed.
8.	When all modules are installed, verify they are connected and operating with command: MENU > STATUS > BATTERIES > NUM MID-STRING V.
	Are the LEDs on the module(s) on (and not red) and are the number of registered modules the same as the number used?
	Yes – Go to Step 10. No – Proceed to Step 9.
9.	Check integrity of all cable connections.
10.	Issue the Clear Events command: MENU > CONTROL / OPERATIONS > CLEAREVENTS. (If the LEDs are still not lit green or if the number of registered modules still does not agree, call your local field representative.)

The controller is now set to monitor both voltage and temperatures to support the battery string voltage imbalance, Slope Thermal Compensation (STC) and battery high temperature disconnect. To enable or verify that STC is active go to **MENU > CONFIGURATION > BATTERIES > BATTERY TEMP MANAGEMNT** and select **TEMPERATURE COMP** and verify that the feature Temperature Comp is Enabled. If not, configure and save it appropriately. Additional parameters associated with slope thermal compensation may be set on the controller to customize this feature.

Local Port (RS-232 / USB) Connection

















This isolated RS-232/USB serial port is used for local PC access or for connection to an external modem. The software interface is compatible with Lineage Power EasyView for Windows GUI software for PCs. Software support is also provided for use with Lineage Power Galaxy Manager for web-based remote access and monitoring. You can download EasyView at omnionpower.com

Click the Downloads button. Select **EasyView Monitoring Software**.

















Using LAN Port for PC Access

The local craft port requires that you use EasyView software. To access the controller from a PC using only your web browser, use the LAN port. The following steps change the LAN connection from the Client (Network) mode to the Server (Local) mode.

Warning: It is always safer to restore the controller in Client mode. This avoids LAN conflicts should the controller ever be connected to a Local Area Network. As good policy, always restore the controller to Client mode.

Step	Action
1.	Press Menu or Accept key,  .
2.	Press down arrow,  , to Configuration.
3.	Press the right arrow key,  (or square “accept” key, ) to advance.
4.	Press down arrow,  , to Communications Ports.
5.	Press the right arrow key,  (or square “accept” key, ) to advance.
6.	Press down arrow,  , to Network Settings.
7.	Press the right arrow key,  (or square “accept” key, ) to advance.
8.	Press down arrow,  , to highlight DHCP.
9.	Press the right arrow key,  (or square “accept” key, ) to advance.
10.	Press down arrow,  , to toggle to SERVER.
11.	Press save,  .
12.	Press the Back Arrow,  , to return to the default screen.
13.	Wait 2 minutes.
14.	Activate changes by removing the latching PWR connection, located on the lower right of the controller, until the LEDs extinguish.
15.	Reapply power by reinserting the PWR connection until latched.
16.	Verify Server Mode by pressing Menu>Status>Network Settings>Port 1> to find 192.168.2.1 as the network address.
17.	Launch the PC’s internet browser and enter 192.168.2.1 in the address bar.

Restore the LAN Connection to Client (Network) Mode

Step	Action
1.	Press Menu or Accept key,  .
2.	Press down arrow,  , to Configuration.
3.	Press the right arrow key,  (or square "accept" key, ) to advance.
4.	Press down arrow,  , to Communications Ports.
5.	Press the right arrow key,  (or square "accept" key, ) to advance.
6.	Press down arrow,  , to Network Settings.
7.	Press the right arrow key,  (or square "accept" key, ) to advance.
8.	Press down arrow,  , to highlight DHCP.
9.	Press the right arrow key,  (or square "accept" key, ) to advance.
10.	Press down arrow,  , to toggle to CLIENT.
11.	Press save,  .
12.	Press the Back Arrow,  , to return to the default screen.
13.	Wait 2 minutes.
14.	Activate changes by removing the latching PWR connection, located on the lower right of the controller, until the LEDs extinguish.
15.	Reapply power by reinserting the PWR connection until latched.
16.	Verify Client Mode by pressing Menu>Configuration>Communications Ports>NetworkSettings> to show Client mode.

Rectifier Installation

All rectifier ac and dc connections are made when rectifiers are installed in the shelf and will power up if ac is applied to the shelf.

Step	Action
1.	Before engaging the rectifier connector into the back of the rectifier slot, press the Latch release button, the latch will spring open. See Figure 11.
2.	Firmly push the rectifier into the rectifier slot until the connector on the rear of the rectifier engages with the connector at the back of the rectifier slot on the CPS shelf. The latch will pop most of the way up when the rectifier is properly seated. Push the latch up into the latched position.
3.	Repeat until all rectifiers are installed.

Releasing the Latch Handle

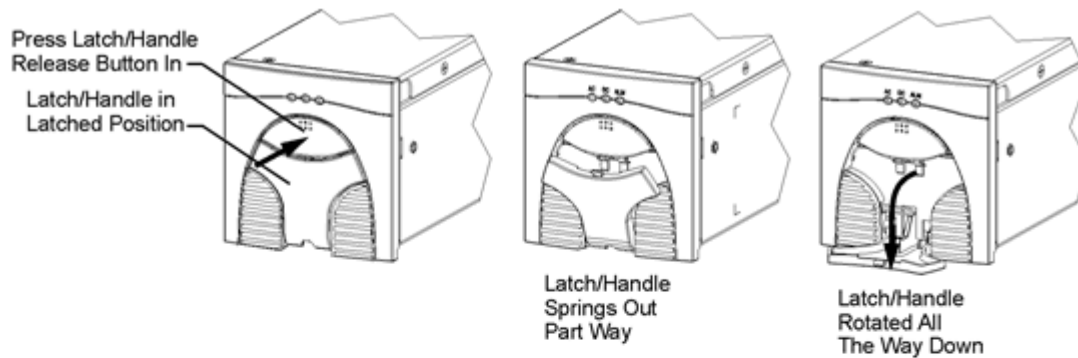

Installing / Removing the Rectifier

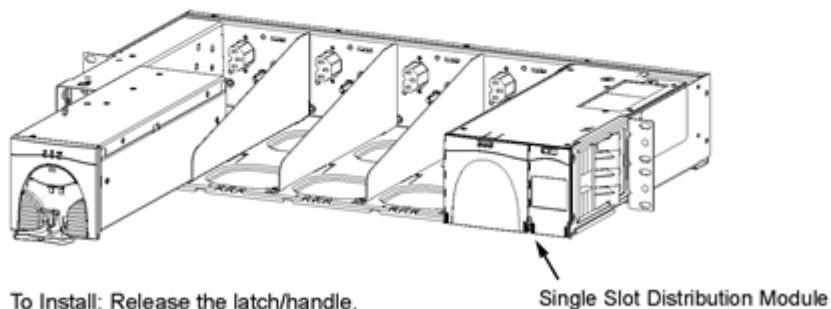

To Install: Release the latch/handle.
 Push the rectifier in firmly until seated.
 The latch/handle will pop most of the way up.
 Push the latch/handle back into the latched position

To Remove: Release the latch/handle.
 Push the latch/handle all the way down (shown).
 Pull the rectifier out by the latch/handle.

Figure 11: Rectifier Installation

4. Initial Start-up

Verify that all AC, DC and Alarm connections are complete and secure. Once this is complete, the AC input breakers may be turned on. If rectifiers have not yet been installed, install rectifiers now as described in Section 3. As each rectifier is installed, the controller automatically identifies the new rectifier and begins communication.

If there are no alarms, make any adjustments to the default settings on the controller that are required for this installation. The following steps cover the minimum configuration of the controller. Refer to the controller sections in Pulsar Controller Manual (167-792-183), comcode CC848815341, for issues like web pages, craft port and changes to settings. Most functions in software are intuitive by referring to the menu map listed in Appendix A.

Minimum Controller Configuration

The controller is preconfigured for Central Standard Time and the following float voltage related settings. If these standard defaults are OK, no configuration is required. Refer to the table below to change these defaults. For more advanced operations, please see the Advanced Features User Guide for the Pulsar Plus Controller.

Alarm	Description
Float Voltage	The factory default setting is 54.5V
Very High Voltage Major	Alarm occurs and the unit is shut down when the system detects voltage above its set threshold. The threshold can be set from 50V to 60V in 1V increments. The factory default setting is 57V
High Voltage Minor	Alarm indicates an abnormally high output voltage but does not shut the unit down. The alarm threshold can be set from 50V to 60V in 1V increments. The factory default setting is 56V.
BD (Battery on Discharge) Major	Alarm occurs when the system is operating either completely or partially on battery power. The alarm threshold can be set from 46V to 55V in 0.1V increments. The factory default setting is 51.0V.
Very Low Voltage Major	Alarm indicates an imminent system shutdown due to discharging batteries or low output voltage. The factory default setting is -46.0V.

Step	Configuration Attribute to Change	Menu Path/Action
1.	Date	
	Format	This field allows you to select one of the following date formats: MM/DD/YY, DD/MM/YY, YY/MM/DD, MM/DD/YYYY, DD/MM/YYYY, YYYY/MM/DD. Use the <+> or <-> key to select the desired format and press <ENTER> to save the change.
	Month	Use this field to change the month; the possible value is from 1 to 12.
	Day	Use this field to change the day of the month; the possible value is from 1 to 31.
	Year	Use this field to change the year; the possible value is from 1992 and up.
NOTE:	Please note that the system will validate the entries before the system date is modified.	
2.	Time	
	Format	This field allows you to select one of the following time display formats: 12 or 24 hour. Use the <+> or <-> key to select desired format and press <ENTER> to save the change.
	Time	Allows you to change/set the time.
Daylight	Enables or Disables Daylight Savings per the new standards created by the Energy Policy Act of 2001. (Started in 2007.)	
3.	Batteries	
	Type	The configuration of this field selects the battery type, Flooded or Valve Regulated (sealed). This parameter is used in reserve time prediction and enhanced battery test features. Move the cursor to the field and use the <+> or <-> key to adjust the threshold value. Press <ENTER> to save the change. Note that the controller will ask to confirm the corresponding float voltage settings.

Step	Configuration Attribute to Change	Menu Path/Action
	<p align="center">Float Voltage</p>	<pre> graph TD MM[Main Menu] --> S[Status] MM --> CO[Control/Operations] MM --> H[History] MM --> C[Configuration] </pre>
4.	<p>From the default screen, press the Display Menu key to see the Main Menu.</p>	<pre> graph LR C[Configuration] --> FS[Float Settings] C --> S[Shunt] C --> R[Rectifiers] C --> B[Batteries] C --> CO[Contactors] C --> BO[Boost] C --> CP[Communication Ports] </pre>
	<p>Press the down arrow key until Configuration is highlighted, press the Display Menu key and the following selections are available; Float settings, Shunt rating, Rectifier Redundancy, Batteries, Contactors, Boost, System Settings, and Communication Ports.</p>	<pre> graph LR C[Configuration] --> FS[Float Settings] FS --> SP[Set Point] FS --> VA[Voltage Alarms] VA --> VHM[Very High Major] VA --> HMin[High Minor] VA --> BDM[BD Major] VA --> VLM[Very Low Major] </pre>
	<p>The Float Settings option will be highlighted, press the Display Menu key to access the Float Settings Menu.</p>	<p>The Set Point option will be highlighted. Press the Display Menu key to view or change the Float voltage Set Point. Use the left and right arrow keys to adjust the Set Point voltage. Once the Voltage has been set to the desired value Press the Display Menu key to save the change. The voltage range is 42.0 to 56.5 Volts. Factory default is -54.5V. Select Voltage Alarms to set the four Voltage Alarm thresholds.</p>

This page intentionally left blank.

4. Troubleshooting

Rectifier Alarms

The rectifier converts ac to dc power for user equipment. This section describes the rectifier features, functions and alarms.

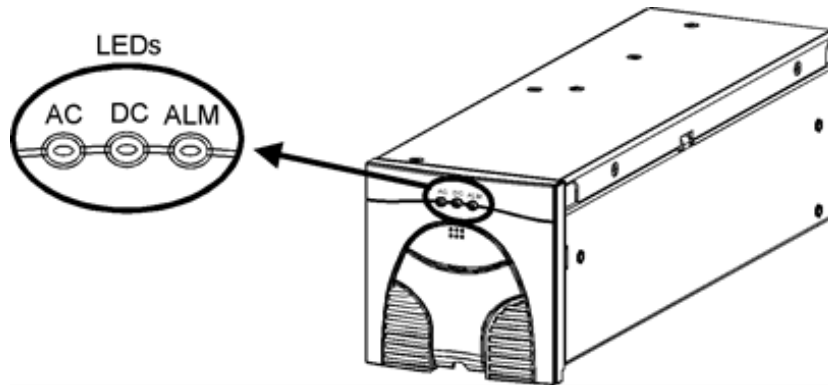

Three LEDs are provided, two green LEDs named AC OK and DC OK, and a red LED named Alarm. Their indications are listed below, followed by complete status descriptions.

LEDs: *= On, x=either state			
AC OK	DC OK	ALARM	Condition
*	*		Normal Operation
*			Start Up, Hiccup, Remote Standby
*		*	High Voltage Shutdown, Thermal Alarm, Internal Failure
			AC Fail, PFC Fail, Input Fuse, Missing AC, LowInput AC > 15 ms
*	Flashing		Current Limit Operation
x	x	Flashing	Communication Loss

Troubleshooting Chart

Controller LED (Note 3)	User Interface Display	Rectifier LEDs (Note 4)			Distribution Module Board LED	Possible Problem(s)	Possible Solution(s)
		AC	DC	ALM			
None	No response.	G	G	-R-	-R-	Controller failure, all devices on the communication bus reporting loss of communication with controller.	<p>Check controller to ensure it is properly inserted into its slot. If so, perform the following steps:</p> <ol style="list-style-type: none"> 1. Remove the controller board for 1 minute and then reset. 2. If problem persists, replace controller with new controller board. 3. If problem still persists, call your local field representative.
RED	MIN, AC Fail MAJ, Multiple AC Fail MAJ, Battery on Discharge	o	o	o		<p>Multiple rectifiers not receiving ac power, batteries are powering load.</p> <p>AC input circuit breakers have opened.</p> <p>AC input voltage is out of range.</p> <p>Internal rectifier fault.</p>	<ol style="list-style-type: none"> 1. Verify ac power to rectifiers is available. 2. Verify rectifier input circuit breakers are closed. 3. If problem is not corrected, replace rectifiers.
RED	MAJ, Battery on Discharge	G	G	o		Rectifier output voltage has fallen below the battery on discharge threshold set by the user.	If commercial ac power is present but the system voltage remains low, call your local field representative. Investigate other alarms that may be present such as rectifier related problems.
RED	MIN, Rectifier Fail MAJ, Rectifier Fail (Note 1)	G	o	R		All rectifier outputs have dropped below 36V, all rectifiers have entered hiccup mode. Defective controller.	Remove controller; if output voltage does not go to set-point previously set by user, call your local field representative.
RED	MAJ, Contactor 1 Open	G	G	o	-A-	One or both of the LVD contactors is open; someone may have manually opened LVD contactor.	Place disconnect switch in ON position.
RED	MAJ, Fuse Major	G	G	o	R	One or more of the output circuit breakers or fuses have opened.	Reset circuit breakers or replace fuse.

Controller LED (Note 3)	User Interface Display	Rectifier LEDs (Note 4)			Distribution Module Board LED	Possible Problem(s)	Possible Solution(s)
		AC	DC	ALM			
RED	MIN, Rectifier Fail MAJ, Multiple Rectifier Fail MAJ, Battery on Discharge	G	o	R	G	Multiple rectifier thermal alarm: Excessive ambient temperature Multiple rectifier failure	<ol style="list-style-type: none"> 1. Verify that there is no obstruction of the vertical airflow path. 2. Reset rectifiers by removing them, waiting approximately 30s and replacing them. 3. If problem persists, replace the rectifiers. 4. If problem still persists, call your local field representative.
RED	MAJ, High Voltage			G	G	High output voltage from rectifier(s) Rectifier(s) high voltage shutdown Internal rectifier(s) failure	<ol style="list-style-type: none"> 1. Reset the rectifier(s) by removing the rectifier(s), waiting approximately 30s and replacing the rectifier(s). 2. If problem persists, replace the rectifier. 3. If problem still persists, call your local field representative.
RED	MAJ, Major Communication Fail	G	G	o	-R- (or missing LVD Board)	LVD Board lost communication with the controller.	<ol style="list-style-type: none"> 1. Replace Distribution Module Board. (Note 2) 2. If problem persists, call your local field representative.
AMBER	MIN, AC Fail	o	o	o		Single Rectifier not receiving ac power. <ul style="list-style-type: none"> • AC input circuit breaker has opened. • AC input voltage is out of range. 	<ol style="list-style-type: none"> 1. Verify ac power to rectifier is available. 2. Verify rectifier input circuit breaker is closed. 3. If problem not corrected, replace rectifier.
AMBER	MIN, Rectifier Fail (Note 1)	G	o	o		Rectifier output has dropped below 36V, rectifier has entered hiccup mode.	Replace rectifier.
AMBER	MIN, Battery High Temperature	G	G	o		Batteries have exceeded temperature threshold set by user.	Call your local field representative.

Controller LED (Note 3)	User Interface Display	Rectifier LEDs (Note 4)			Distribution Module Board LED	Possible Problem(s)	Possible Solution(s)
		AC	DC	ALM			
AMBER	MIN, Thermal Probe Fail	G	G	o		Battery thermal probe failed.	<ol style="list-style-type: none"> 1. Ensure thermal probe is properly connected to thermal probe cable. 2. Ensure cable is properly connected to the rear of the Distribution Module. 3. If problem persists, replace thermal probe per ensuing instructions. 4. If problem still persists, call your local field representative.
AMBER	MIN, Rectifier Fail	G	o	R		<p>Single rectifier thermal alarm: Excessive ambient temperature</p> <p>Multiple rectifier failure</p>	<ol style="list-style-type: none"> 1. Verify that there is no obstruction of the vertical airflow path. 2. Reset the rectifier by removing the rectifier, waiting approximately 30 seconds, and replacing the rectifier. 3. If problem persists, replace the rectifier. 4. If problem still persists, call your
AMBER	<p>MIN, Minor Communication Fail</p> <p>(Single Rectifier signaling)</p>			-R-		Rectifier lost communication with controller.	<ol style="list-style-type: none"> 1. If a rectifier has been removed from an installed/operational system, go to the Control/Operations menu and execute Uninstall Equipment. 2. Reset the rectifier by removing the rectifier, waiting approximately 30 seconds, and replacing. 3. If problem persists, replace the rectifier. 4. If problem still persists, call your local field representative.

6. Product Warranty

A. Seller warrants to Customer only, that:

1. As of the date title to Products passes, Seller will have the right to sell, transfer, and assign such Products and the title conveyed by Seller shall be good;
2. During the warranty period stated in Sub-Article B below, Seller's Manufactured Products (products manufactured by Seller), which have been paid for by Customer, will conform to industry standards and Seller's specifications and shall be free from material defects;
3. With respect to Vendor items (items not manufactured by Seller), Seller warrants that such Vendor items, which have been paid for by Customer, will be free from material defects for a period of sixty (60) days commencing from the date of shipment from Seller's facility.

B. The Warranty Period listed below is applicable to Seller's Manufactured Products furnished pursuant to this Agreement, commencing from date of shipment from Seller's facility, unless otherwise agreed to in writing:

Product Type	New Product	Repaired Product
Central Office Power Equipment	24 Months	6 Months

Warranty Period

* The Warranty Period for a repaired Product or part thereof is six (6) months or, the remainder of the unexpired term of the new Product Warranty Period, whichever is longer.

C. If, under normal and proper use during the applicable Warranty Period, a defect or nonconformity is identified in a Product and Customer notifies Seller in writing of such defect or nonconformity promptly after Customer discovers such defect or nonconformity, and follows Seller's instructions regarding return of defective or nonconforming Products, Seller shall, at its option attempt first to repair or replace such Product without charge at its facility or, if not feasible, provide a refund or credit based on the original purchase price and installation charges if installed by Seller. Where Seller has elected to repair a Seller's Manufactured Product (other than Cable and Wire Products) which has been installed by Seller and Seller ascertains that the Product is not readily returnable for repair, Seller will repair the Product at Customer's site.

With respect to Cable and Wire Products manufactured by Seller which Seller elects to repair but which are not readily returnable for repair, whether or not installed by Seller, Seller at its option, may repair the cable and Wire Products at Customer's site.

D. If Seller has elected to repair or replace a defective Product, Customer shall have the option of removing and reinstalling or having Seller remove and reinstall the defective or nonconforming Product. The cost of the removal and the reinstallation shall be borne by Customer. With respect to Cable and Wire Products, Customer has the further responsibility, at its expense, to make the Cable and Wire Products accessible for repair or replacement and to restore the site. Products returned for repair or replacement will be accepted by Seller only in accordance with its instructions and procedures for such returns. The transportation expense associated with returning such Product to Seller shall be borne by Customer. Seller shall pay the cost of transportation of the repaired or replacing Product to the destination designated by Customer.

- E. Except for batteries, the defective or nonconforming Products or parts which are replaced shall become Seller's property. Customer shall be solely responsible for the disposition of any batteries.
- F. If Seller determines that a Product for which warranty service is claimed is not defective or nonconforming, Customer shall pay Seller all costs of handling, inspecting, testing, and transportation and, if applicable, traveling and related expenses.

- E. Seller makes no warranty with respect to defective conditions or nonconformities resulting from actions of anyone other than Seller or its subcontractors, caused by any of the following: modifications, misuse, neglect, accident, or abuse; improper wiring, repairing, splicing, alteration, installation, storage, or maintenance; use in a manner not in accordance with Seller's or Vendor's specifications or operating instructions, or failure of Customer to apply previously applicable Seller modifications and corrections. In addition, Seller makes no warranty with respect to Products which have had their serial numbers or month and year of manufacture removed, altered, or experimental products or prototypes or with respect to expendable items, including, without limitation, fuses, light bulbs, motor brushes, and the like. Seller's warranty does not extend to any system into which the Product is incorporated. This warranty applies to Customer only and may not be assigned or extended by Customer to any of its customers or other users of the Product.

THE FOREGOING WARRANTIES ARE EXCLUSIVE AND ARE IN LIEU OF ALL OTHER EXPRESS AND IMPLIED WARRANTIES, INCLUDING BUT NOT LIMITED TO WARRANTIES OF MERCHANTABILITY AND FITNESS FOR A PARTICULAR PURPOSE. CUSTOMER'S SOLE AND EXCLUSIVE REMEDY SHALL BE SELLER'S OBLIGATION TO REPAIR, REPLACE, CREDIT, OR REFUND AS SET FORTH ABOVE IN THIS WARRANTY.

Appendix A: Pulsar Controller

User Interface Overview

The Galaxy Pulsar monitors and controls system components including rectifiers, converters, and distribution modules via a multi-drop RS485 digital communications bus. System status, parameters, settings, and alarm thresholds can be viewed and configured from the controller's front panel display. Assignment and configuration of alarm inputs and output relays can be performed from a laptop computer connected to a local RS-232 or LAN Ethernet port, or by remote access through a network connection to the World Wide Web (internet) or your enterprise network (intranet).

This section describes the controller features, functions and alarms from perspective of a user utilizing the front panel display. All these features are available through the local craft port using Easy View software or the LAN port using a PC web browser. Easy View is a Lineage Power Systems GUI provided for local serial port or remote MODEM access.

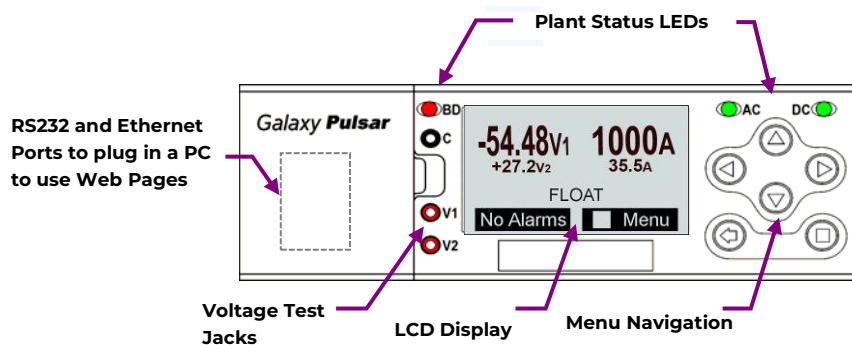





The display shows the rectifiers -48 voltage (V2) and current. If converters were present, their voltage would display as V1. The display (V1 versus V2) correlates with test jacks. The large font indicates the "Primary" or rectifier dc bus; the smaller font shows the "Secondary" or converter dc bus. For systems with no converters only a single voltage/current pair will be displayed on the front panel along with the correct test jack association. The other test jack will be unused and will have near zero voltage.

Menu Navigation Buttons

The NE843 has six tactile buttons to use to navigate through a structured menu system. The buttons serve multiple purposes depending on the screen a user is at. These functions are summarized below.

Menu Navigation Buttons

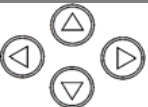
The NE843 has six tactile buttons to use to navigate through a structured menu system. The buttons serve multiple purposes depending on the screen a user is at. These functions are summarized below.





Buttons	Description	
	Display Contrast	In the Main Display, the ▲▼ buttons increase or decrease the display contrast.
	Parameter Change	Contrast adjustment is also available through the menus at Menu+Configuration+System Settings .
		When changing a system parameter, the ▲▼ buttons increase or decrease the value of the parameter.
	Direction Buttons	In the Menus, the ◀▶ direction buttons navigate to make a selection. A black box highlighting a menu item indicates that the item has sub-menus.
	Enter Button	Enters a sub-menu or confirms a parameter change. From the Home Page only, goes to the top level Main menu.
	ESC Button	Goes up one menu level or exits a parameter change without saving.

System Status Display

LCD Backlight

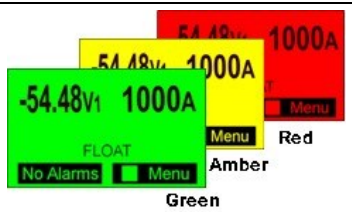
The controller has an alarm sensitive back-light indicator to provide a clear indication of the system status. Severities of alarms can be configured through the remote interfaces.

Following is a basic description of the backlight functionality.

	<p>There are three basic colors to indicate the alarm severity present in the system: Green, Amber, and Red</p> <p>The highest severity in the system will take precedence.</p>	
Status	Function	Condition
 green	Normal	Normal operation, no alarms, inputs and outputs are in their normal range.
 red	Critical Alarm	Highest severity. Generally assigned to alarm to indicate a Power affecting condition. Immediate attention required.
 red	Major Alarm	High severity. Generally assigned to alarm to indicate a Power affecting condition. Immediate attention required.
 amber	Minor Alarm	Medium severity. Generally assigned to alarm to indicate a non-power affecting condition. Attention eventually required.

Status LEDs

The controller has LED indicators for more specific information on AC, DC and Battery on Discharge states. These LEDs have factory assigned defaults as indicated in the table below. However, the assignments to alarms can be customized in the field using the remote interfaces

LED	Status	Condition
AC	green	AC input to all rectifiers is in range.
	amber	AC input to one rectifier is missing or out of range.
	red	AC input to two or more rectifiers is missing or out of range.
DC	green	DC output to all loads is normal.
	amber	One or more of the following alarms are present: Fuse Minor
	red	One or more of the following alarms are present: Open String, LVBD Open, Fuse Major
BD	green	System above configured Battery on Discharge (BD) threshold.
	green	Blinks at an On/Off Rate of 1/2 second ON 1/4 second Off to indicate a manual or automatic battery test in progress.
	amber	State not presently assigned.
	red	System equal to or below configured Battery on Discharge(BD) threshold.

Audible Alarm



The Pulsar NE843 has an integrated audible alarm located in its display assembly. This alarm will sound when any Critical, Major, or Minor alarm is detected by the controller. Upon assertion of the audible alarm the default front panel will provide an indicator of the alarm as well as a quick link to temporarily cut-off the alarm.

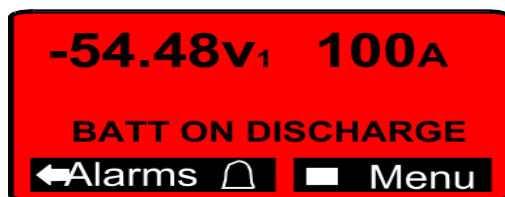

Pressing the arrow key provides a quick link to temporarily cut-off the audible alarm.



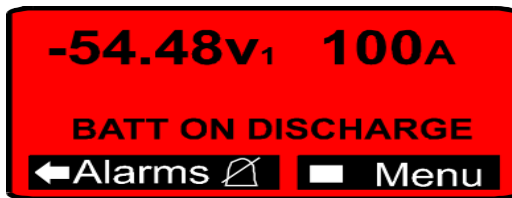

Once the audible cut-off is selected the alarms present in the system are listed. An indicator on the default front panel screen is provided to inform that the audible alarm cutoff is active. The audible alarm can also be turned-back on following similar procedures.



The audible alarm may be disabled altogether through proper configuration at the front panel or through remote means.

Voltage Test Jacks

- Three test jacks allow measurement of the system voltage with a hand-held meter. The jacks are referenced with C (Common), V1 (Not Used in this system), and V2 (-48 Voltage). Measurement between C and V2 jacks corresponds to the voltage referenced on the default front panel screen
-  C
 -  V1
 -  V2

Local Craft Port

The local DB-9 RS232 asynchronous serial port is behind a cover on the front panel. A laptop PC can be connected to the DB9 connector to provide a ground-referenced RS-232 serial connection using EasyView for local access. The port can also be configured to be used with an external modem. There is also space allocated for a RJ45 or USB receptacle. The LAN (Ethernet) port is located on the controller board.



Front Panel Menu Structure

Feature content at the front panel is functionally divided at the NE843's Main Menu into the following categories:

- Alarms
- Warnings
- Status
- Control/Operations
- History
- Configuration

Access to the main menu starts at the default front panel screen shown below.

<p>Front Panel Default Menu</p>	<p>The front panel default screen displays the primary and secondary (if present) bus voltages along with their respective total load in two different fonts.</p> <p>The operating mode of the system is also displayed. The displayed operating modes possible are: Float, Battery On Discharge, Boost, etc.</p> <p>An alarm soft-key as well as the backlight will indicate when alarms are present. Pressing the c will access the alarm cut-off as well as the alarms and warnings present in the system.</p> <p>Pressing the o button accesses the main menu and the feature categories previously listed.</p>
<p>Main Menu</p>	<p>Access to alarms, warnings, equipment status detail, basic control and operations for maintenance purposes, and system configuration.</p> <p>Note: the NE843 has the ability to have a front Panel Password that limits configuration as well as some operations. A person with administrator level access can enable this feature through the remote interfaces. Standard controllers are shipped from the factory with this feature disabled.</p>

Front Panel Menu Flow

The following figures provide a menu flow map for each primary category. This information is followed up with brief descriptions of each of the menu items. Alarms and Warnings are not hierarchical mapped and are presented in chronological order of occurrence when they are present. No Active Alarms or No Active Warnings will be displayed when they are no alarms or warnings detected by the controller.

Status Menu

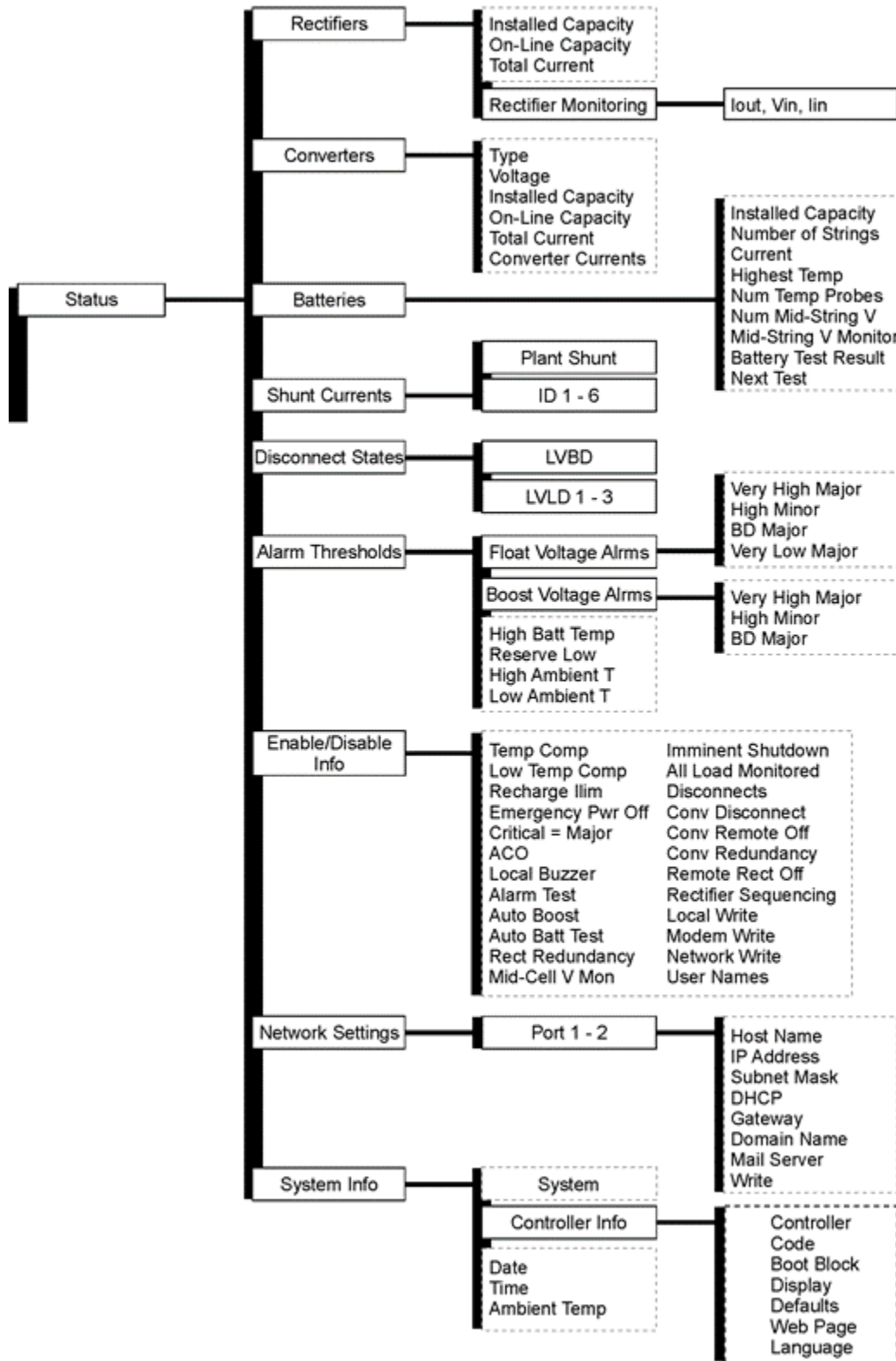

Status Menu

Control / Operation
and
History Menus

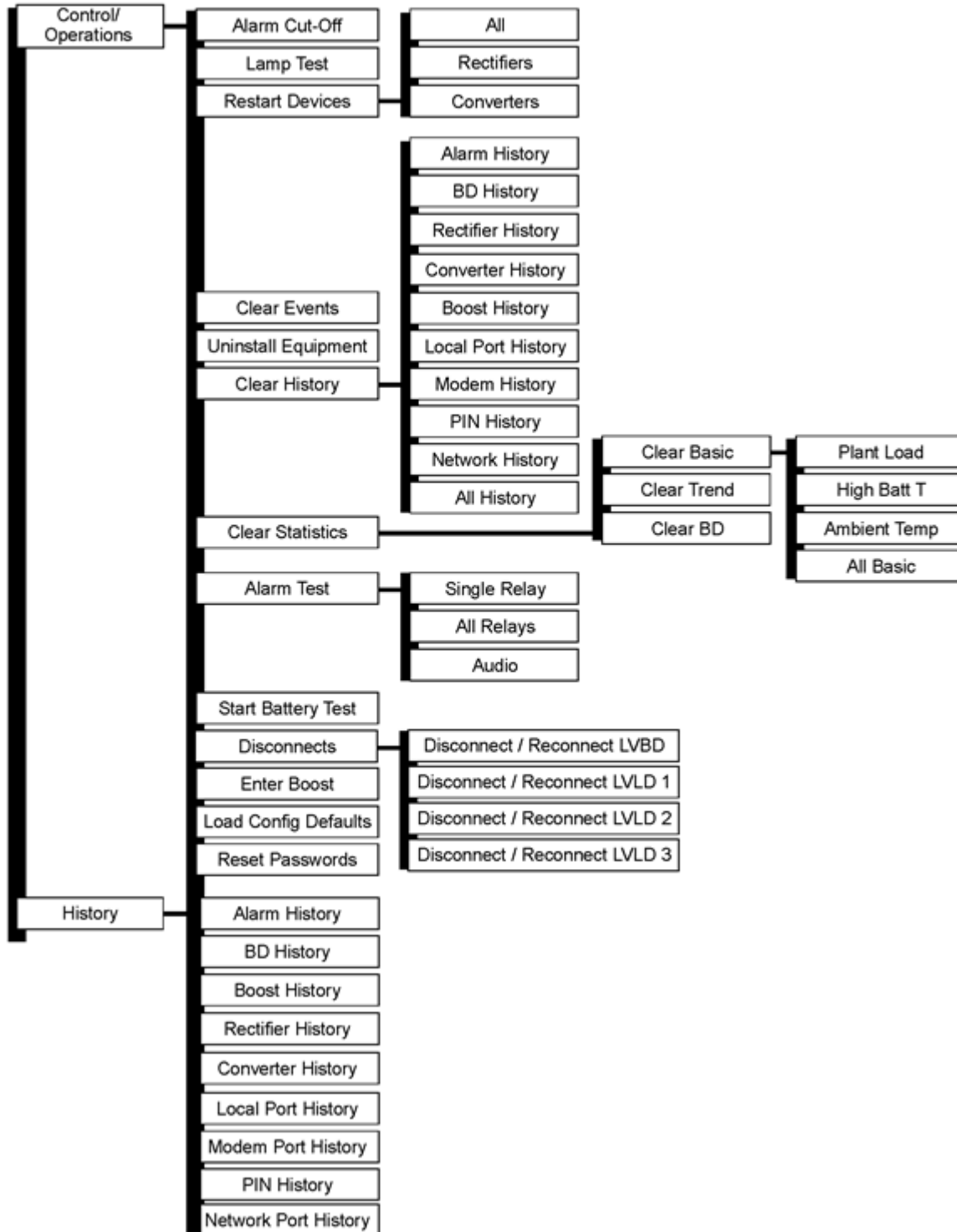

Control / Operations and History Menus

Configuration Menu

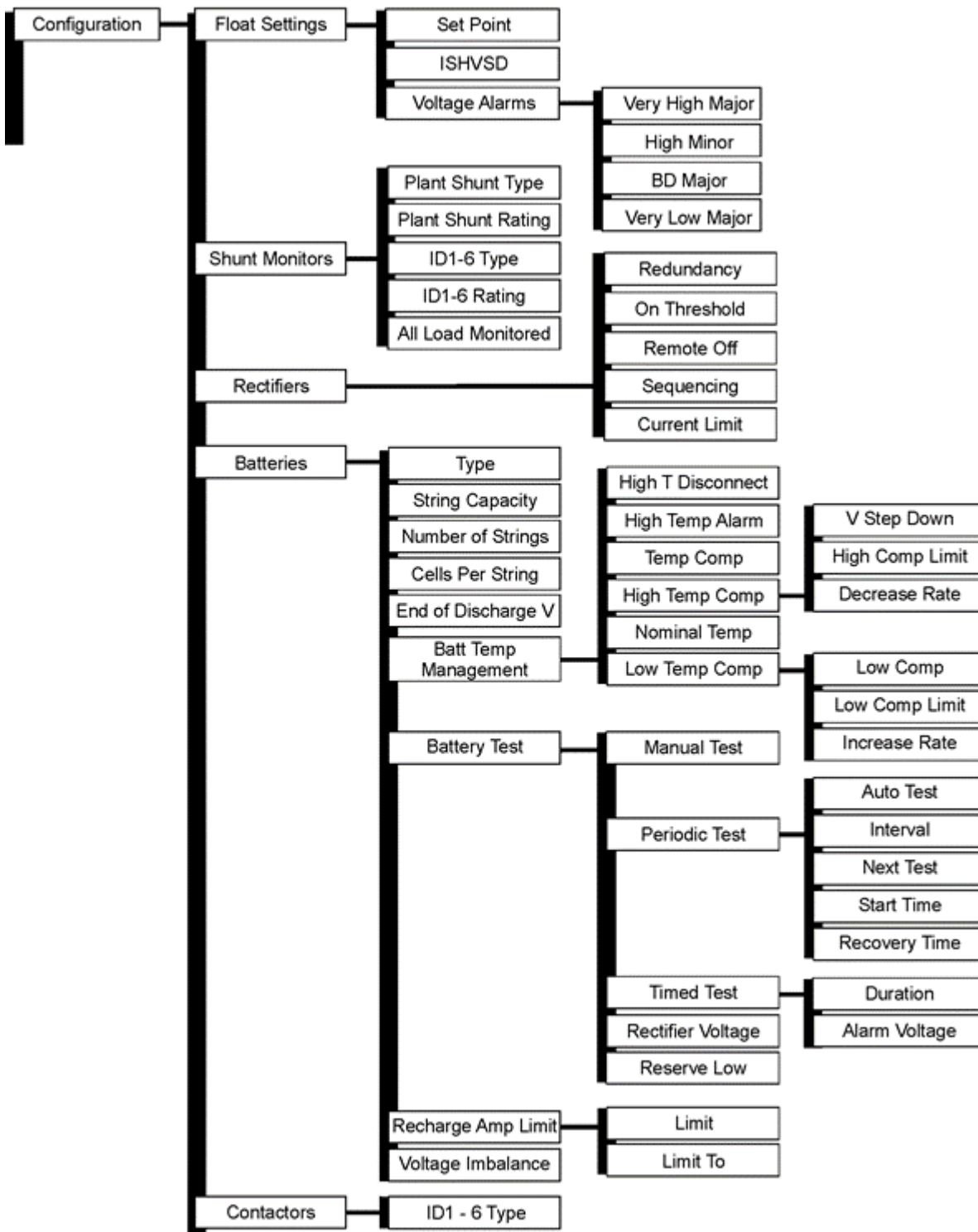

Continued on
Next Page

Configuration Menu (part 1)

Configuration Menu
(continued)

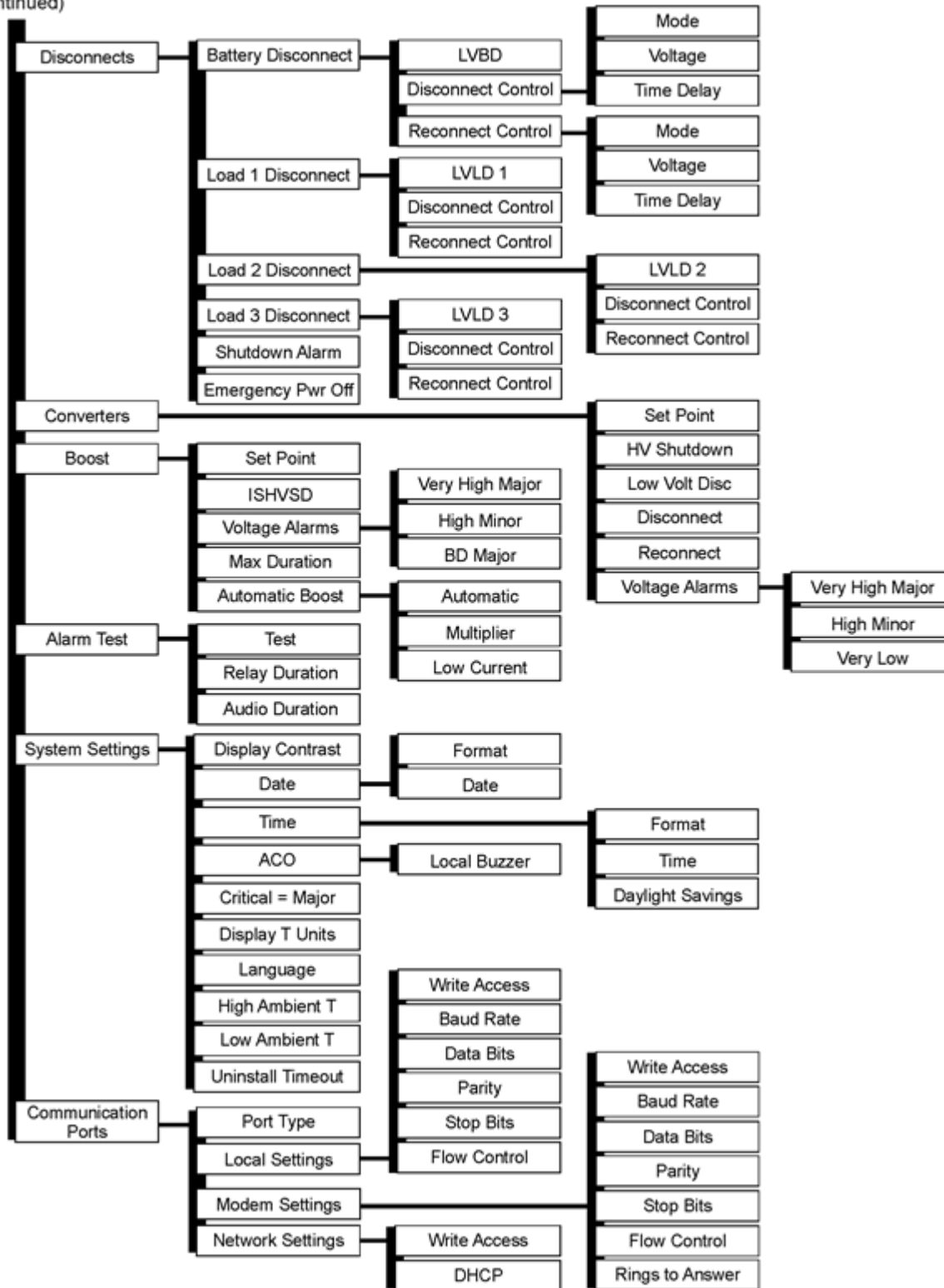

Configuration Menu (part 2)

This page intentionally left blank.

Appendix B: Pulsar Wiring Connector Definitions

One-Wire Battery Peripheral Connector

Temp is a standard shielded RJ-45 receptacle provided for making connections to one-wire QS873 VT-Probes and or to the ES771A Remote Mid-string Voltage Monitor. Standard cable assemblies have been designed and are available for different applications with the QS873 VT-Probes or ES771 Remote Mid-string Voltage monitors that allow simple plug-n-play.

Pin #	SignalName	Description
1	reserved	
2	reserved	
3	SIG_RTN	Protected signal return for 1-wire
4	reserved	
5	1-Wire	1-wire communication signal
6	+5V	Protected +5V Power utilized by ES771 modules
7	reserved	
8	reserved	

Pin # (Wire Color)	Signal Name	Description
1 (BK)	Aux Input 1 (Aux1)	Auxiliary input to monitor a contact closure or open to its respective return on pin 8, Auxiliary Input Return.
2 (BR)	Aux Input 2 (Aux2)	Auxiliary input to monitor a contact closure or open to its respective return on pin 8, Auxiliary Input Return.
3 (R)	Aux Power Major Input (AMJ)	Auxiliary input to monitor a contact closure to the non-grounded side of a dc bus (-48V) to create the standard Auxiliary Power Major alarm.
4 (O)	Plant Battery Test/ GroupStandby/TR (GSTR)	Dedicated input to be monitored for a contact closure to its respective return on pin 9. Used for Plant Battery Test and Group Standby Feature. Factory default as the Group Standby feature upon a contact closure.
5 (Y)	Emergency Power Off (EPO)	Dedicated EPO input to be monitored for a contact closure to its respective return on pin 10, Emergency Power Off Return.
6 (G)	Aux Input 3 (Aux3)	Auxiliary input to monitor a contact closure or open to its respective return on pin 8.
7 (BL)	Aux Input 4 (Aux4)	Auxiliary input to monitor a contact closure or open to its respective return on pin 8.
8 (V)	Aux Input Return (Aux_R)	Return for Auxiliary Inputs 1-4.
9 (S)	Plant Battery Test/ GroupStandby (TR) Ret. (GSTR_R)	Return for Plant Battery Test and Group Standby.
10 (W)	Emergency Power Off Ret. (EPO_R)	Return for EPO input.

Input Alarms Connector

Input Alarms is 10-pin right angle header that provides a separate connection for auxiliary inputs. Standard color coded cable assemblies are available. Comcodes for the 15', 50' and 150' input cables are CC848865980, CC848817651 and CC848817668, respectively. Contact technical field support for additional cable options

Office Alarm Connector

All standard controller output alarm connections are available from the output connector. Connector J4 provides access to the primary customer alarm output interface. Connector J4 is a 20-pin right angle header with latching capability. Standard color coded cable assemblies are available. Comcodes for the 15', 50' and 150' input cables are CC109157442, CC848817635 and CC848817643, respectively.

Contact technical field support for additional cable options.

Pin # (Wire Color)	Signal Name	Pin # (Wire Color)	Signal Name	NE843 Standard Defaults
1 (BL)	PCR	11 (W)	PCR_C	PCR (Power Critical)
2 (O)	PMJ	12 (W)	PMJ_C	PMJ (Power Major)
3 (G)	PMN	13 (W)	PMN_C	PMN (Power Minor)
4 (BR)	UR1	14 (W)	UR1_C	BD (Battery on Discharge)
5 (S)	UR2	15 (W)	UR2_C	VLV (Very Low Voltage)
6 (BL)	UR3	16 (R)	UR3_C	FAJ (External Fuse Major)
7 (O)	UR4	17 (R)	UR4_C	ACF (ac Fail)
8 (G)	UR5	18 (R)	UR5_C	RFA (Rectifier Fail)
9 (BR)	UR6	19 (R)	UR6_C	MRFA (Multi Rectifier Fail)
10 (S)	UR7	20 (R)	UR7_C	HV (High Voltage)

Note: Configuration jumpers for the alarm outputs have been set to provide an “Open” on alarm from the factory. Alarm contact type can be changed – see Advanced Features User Guide.

Network (LAN) Connection (Optional)

The NE843 provides an Ethernet connection for a LAN and or Craft port connection. Connector LAN provides a standard RJ45 shielded receptacle connection for a standard Cat-5 connection to the controller’s 10/100Base-T port. This port has two main modes of operation: Server mode, LAN mode (Static and DHCP Client). In Server mode the port can be used as a local Craft interface. In this mode, a local laptop can be connected through LAN and its standard web browser used to directly access the controller by typing in network address <http://192.168.2.1>. A connection should never be made between the controller and LAN while the controller is in Server mode.

In Static or DHCP Client modes of operation the controller is supplied an IP address and other network parameters and can be remotely monitored and accessed through the LAN. This is generally a permanent connection between the controller and LAN so a Shielded Cat-5 cable is suggested.

This page intentionally left blank.

7. Revision

Revision	Description	Date
1.2	Updated as per template	02/22/2022
1.3	Updated page footer; corrected to "Installatiion Guide"	4/17/23
1.4	Updated as per OmniOn template.	12/11/2023

OmniOn Power Inc.

601 Shiloh Rd.
Plano, TX USA

omnionpower.com

We reserve the right to make technical changes or modify the contents of this document without prior notice. OmniOn Power does not accept any responsibility for errors or lack of information in this document and makes no warranty with respect to and assumes no liability as a result of any use of information in this document.

We reserve all rights in this document and in the subject matter and illustrations contained therein. Any reproduction, disclosure to third parties or utilization of its contents – in whole or in parts – is forbidden without prior written consent of OmniOn Power. This document does not convey license to any patent or any intellectual property right. Copyright© 2023 OmniOn Power Inc. All rights reserved.