

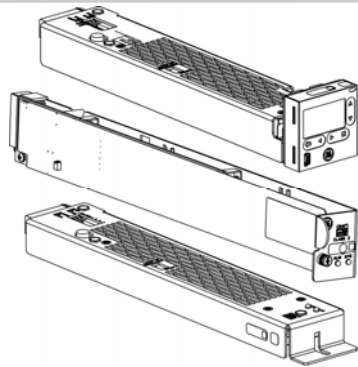

Galaxy Pulsar Edge Controller

Models: many



Typical Controllers

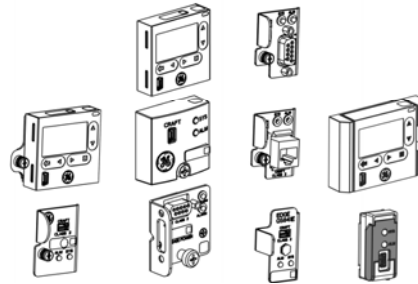

Typical Controller Faces

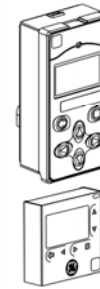

Typical Separate Displays

The Galaxy Pulsar Edge Controller is the system controller of many GE power system families. The various models provide system family compatibility and user interface variants.

This guide is intended to provide basic information for controller installation, start up, and operation.

Application specific installation information is provided in equipment documentation (quick start guides, installation guides, and product manuals).

A Quick Start Guide Supplement provides customer specific Default Voltage Settings and Alarm Signal assignments when they are factory configured.

Controller detail is available in the *Pulsar Edge Controller Family Product Manual* (CC848815341) available at www.gecriticalpower.com.

Step 1 - Set Jumpers - LAN Port and Alarm Relay

Before installing the controller configure the jumpers - top or side of the controller.

Controller Jumper Settings

LAN Port - J5	Configure and view system parameters using EasyView2 software or a web browser. Default IP address is 192.168.2.1.	
	CAUTION: Do not connect LAN port to a network when jumper is set to Local.	
	Local (Server): J5 LAN connects to a laptop. Local (Server) is a temporary setting, once configuration is complete move the jumper back to Network (Client) mode.	Network (Client): J5 LAN connects to a network. (Default).
Alarm Relays	Alarm Relays can be set to operate as Close on Alarm or Open on Alarm. Open on Alarm is the Factory Default setting. Move Alarm jumpers to Close on Alarm when required. The number of alarm relays in a controller is indicated in the model number as nR. Example: MODEL: CP841A_0I6R has 6 alarm relays - PMJ, PMN, 1, 2, 3, and 4. Relays 1 - 4 are assigned specific functions as described in equipment documentation.	



Controller Jumper Location (Side or Top)

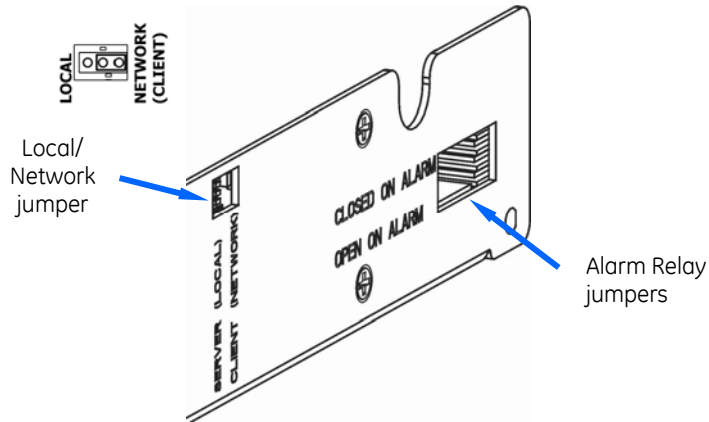

Alarm Relay Jumpers Examples																						
Controller Type	Factory Settings																					
0I6R (6 Relays)	<table border="0"> <tr> <td>4</td> <td>3</td> <td>2</td> <td>1</td> <td>PMN</td> <td>PMJ</td> <td></td> </tr> <tr> <td>●</td> <td>●</td> <td>●</td> <td>●</td> <td>●</td> <td>●</td> <td></td> </tr> <tr> <td>■</td> <td>■</td> <td>■</td> <td>■</td> <td>■</td> <td>■</td> <td>Close on Alarm Open on Alarm</td> </tr> </table>	4	3	2	1	PMN	PMJ		●	●	●	●	●	●		■	■	■	■	■	■	Close on Alarm Open on Alarm
4	3	2	1	PMN	PMJ																	
●	●	●	●	●	●																	
■	■	■	■	■	■	Close on Alarm Open on Alarm																
3C3R (3 Relays)	<table border="0"> <tr> <td>4</td> <td>3</td> <td>2</td> <td>1</td> <td>PMN</td> <td>PMJ</td> <td></td> </tr> <tr> <td>●</td> <td>●</td> <td>●</td> <td>●</td> <td>●</td> <td>●</td> <td></td> </tr> <tr> <td></td> <td></td> <td></td> <td>■</td> <td>■</td> <td>■</td> <td>Close on Alarm Open on Alarm</td> </tr> </table>	4	3	2	1	PMN	PMJ		●	●	●	●	●	●					■	■	■	Close on Alarm Open on Alarm
4	3	2	1	PMN	PMJ																	
●	●	●	●	●	●																	
			■	■	■	Close on Alarm Open on Alarm																
9C0R (no Relays)	None																					

Step 2 - Install Controller in Shelf

SPS Controllers with display snap into the shelf slot. Other Controllers are secured with a latch or screw.

The Controller installs into the left most slot of a compatible shelf with slots or into a controller backplane within a compatible shelf.

1. Install the Controller Bracket. Torque to 5 in-lb (0.5 Nm) (NE Controllers with display only).
2. Replace the latch on the front with the bracket for screw mount if necessary (CP applications only)
Snap off latch. Snap on bracket for screw.
3. Open the latch on the front if present.
4. Firmly slide the controller into the shelf or backplane.
CAUTION: DO NOT press on LEDs or LCD.
5. Secure with screw or latch, if present.

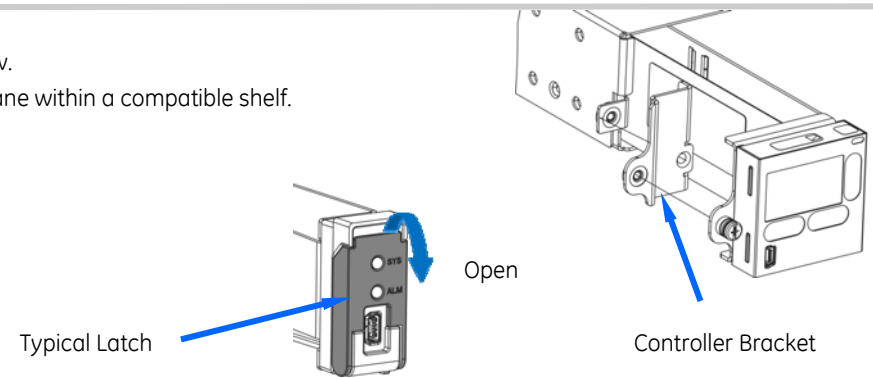

Step 3 - Set Shelf IDs - per shelf Quick Start Guides - some shelves

Shelf ID switches and jumpers are located on the rear of some rectifier/converter shelf models - see shelf quick start guides for location.

Shelf ID must be unique and in the range of 1 to F.

Set rectifier/converter shelf IDs in sequence beginning with 1 at the top shelf.

ID	Shelf
1	Top
2	
3	
4	

Step 4 - Install Signal and Communications Cables

Communications cables are connected at the rear of many systems.

Install communications cables as instructed in equipment documentation and in site engineering instructions.

See *Information: Connectors*.

Step 5 - Install 1-Wire Battery Temp, Ambient Temperature, and Voltage Monitor - Optional

Install 1-Wire Battery Temp, Ambient Temperature, and Voltage Monitor as instructed in equipment documentation and in site engineering instructions.

See *Information: 1-Wire Battery Temp and Voltage Monitor*.

Step 6 - System Initial Start Up

Power the controller - follow the system start up procedure as instructed in equipment documentation and in site engineering instructions.



Step 7 - Configure Controller

Verify and edit controller basic configuration parameters per site engineering instructions.

CAUTION: 1. **DHCP / Static IP Address** - set per site engineering instructions to assure network access.

2. **Converter Voltage Set Point** -

Set both **Converter Internal Selective High Voltage Shutdown** and **Converter High Output Voltage Major Alarm** higher than desired Converter Voltage Set Point. **before** setting Converter Voltage Set Point.

Converters will not operate when either of these parameters is set to less than the Converter Voltage Set Point.

See Information: *Basic Operation*

Basic Configuration - minimum for operation and communication

Basic Configuration		
Parameter	Browser or EasyView	Display Menu
Controller		
System Date, System Time	Installation tab	Configuration > System Settings
Site ID, Site Description	Installation tab	Browser or EasyView only
Shelf J-Code or Product Code	Installation tab	Browser or EasyView only
DHCP / Static IP Address	Network page (Settings tab, Communications group)	Configuration > Communications Ports > Network Settings
Shelves	Shelves page (Settings tab, System group)	Browser or EasyView only
Rectifier		
Float Set Point	Rectifier page (Settings tab, Power group)	Configuration > Float Settings > Set Point
Converter		
Internal Selective High Voltage Shutdown	Converter page (Settings tab, Power group)	Configuration > Converters Settings > HV Shutdown
High Output Voltage Major Alarm	Converter page (Settings tab, Power group)	Configuration > Converters > Voltage Alarms > High Major
Voltage Set Point	Converter page (Settings tab, Power group)	Configuration > Converters > Set Point
Battery		
Plant Shunt	Shunts page (Settings tab, System group)	Configuration > Shunt Monitors > Built In
Battery Disconnect	Contactors page (Settings tab, System group)	Configuration > Contactor Interfaces > Build In - type "LVBD"
Ringer		
Output Frequency	Ringer page (Settings tab, Power group)	Configuration > Ringers > Frequency
Voltage	Ringer page (Settings tab, Power group)	Configuration > Ringers > Voltage
Offset Voltage	Ringer page (Settings tab, Power group)	Configuration > Ringers > DC Offset
Ringer Alarms	Ringer page (Settings tab, Power group)	Configuration > Ringers > Redundancy
Line Power (Remote Power or FTTN)		
Alarms	FTTN page (Settings tab, System group)	Configuration > FTTN > Mult Fail, Redundancy, Load Drop, Load Share



Advanced Configuration - complete, site specific configuration

Verify and edit remaining controller parameters per site engineering instructions.

Information: Controller Default Voltage Settings and Ranges

Configure these parameters per site engineering instructions.

See Quick Start Guide Supplements for customer specific Default Settings.

Rectifier & Battery Management	24V				48V			
	Standard Default Voltage Settings and Ranges ¹	Range	Default ¹ Valve-Reg	Flooded	NiCd	Range	Default ¹ Valve-Reg	Flooded
Float Voltage	21 to 28V	27.24	26.04	27.2	42 to 556.5V	54.48	52.08	54.40
Boost Voltage	22 to 30	27.24	25.00	27.20	48 to 58V	55.20	57.00	54.40
Rectifier Float Selective High Voltage Shutdown	25 to 30V	29.25	29.25	29.25	-50 to -60V	58.50	58.50	58.50
High Float Voltage Major Alarm	25 to 30V	28.24	28.24	28.24	-50 to -60V	57.00	57.00	57.00
High Float Voltage Minor Alarm	25 to 30V	27.74	27.74	27.74	-50 to -60V	56.00	56.00	56.00
Rectifier/System Float Voltage	21 to 28.25V	27.24	25.00	27.20	-42 to -56.5V	54.48	52.08	54.40
Battery on Discharge Float Alarm	23 to 27.25V	25.54	25.00	25.54	-46 to -55V	51.00	50.00	51.00
Very Low Float Voltage Alarm	20 to 25.5V	23.00	23.00	23.00	-40 to -51V	46.00	46.00	46.00
Rectifier On Threshold	20 to 25.5V	22.00	22.00	22.00	-40 to -51V	44.00	44.00	44.00

Converter Management	24V Output		48V Output	
	Standard Default Voltage Settings and Ranges ¹	Range	Default ¹	Range
Internal Selective High Voltage Shutdown	25 to 30V	29.0	50 to 60V	58.0
High Output Voltage Major Alarm	25 to 30V	28.5	50 to 60V	56.0
High Float Voltage Minor Alarm	24 to 30V	27.0	48 to 60V	54.0
Output Voltage	23 to 27.2V	26.0	46 to 54.4V	52.0
Low Voltage Alarm	20 to 27.0V	23.0	40 to 54V	46.0

1. Customer specific factory defaults - see the Quick Start Guide Supplement.

Information: Connectors

See equipment Quick Start Guides and Quick Start Guide Supplements for details of connector, factory signal assignments, and available cables.

Connectors are on the primary shelf (equipped with controller), usually at the rear.

Physical styles and locations of system mounted connectors are system specific.

Not all connectors are present on all systems.

Connector	Label	Position ¹	Function	Connect to
J1	ALARMS		Alarm Input and Output	Office Alarm Block (alarm outputs) and Alarm Inputs
J2 ²	ALARMS		Alarm Input	Alarm Inputs
J3/J4 (RJ-45)	DATA	Upper	1-Wire	1-Wire devices
		Lower	GE Device Comm	Compatible shelves via Daisy Chain
J5 (RJ-45)	LAN		10/100Base-T	Network or Local PC
J7	DIST		Distribution Signals	Compatible Distribution Shelf

1. DATA connectors (J3 and J4) are usually positioned one above the other. Use only the upper connector for 1-Wire devices. See equipment Quick Start Guide.
2. ALARM connections (J2)
Some systems split alarm signals between J1 and J2.
Some systems provide all alarm signals on J1, omitting J2.
See equipment Quick Start Guide for details.



Information: Alarms - Power Minor (PMN) and Power Major (PMJ)

PMN reports during every minor alarm condition.
 PMJ reports during every major alarm condition.

Information: 1-Wire Battery Temp, Ambient Temperature, and Voltage Monitor

1-Wire Monitoring is accomplished with a "Daisy Chained" series of probes connected to the upper DATA connector (J3/J4) on the primary shelf (equipped with controller).

Battery Probes monitor battery temperature and voltage (ES771 required to monitor voltage).

Bolt the Battery Probe under battery "-" terminal connector hardware; NOT under the connecting lug.

Ambient Probes monitor ambient temperature.

Mount the Ambient probe as desired.

All 1-Wire probes may be connected to any 1-Wire daisy-chain using the wiresets listed below.

Max per system: Probes - 16, ES771 Modules - 6.

1. Mount and wire probes per the instructions included with each probe.

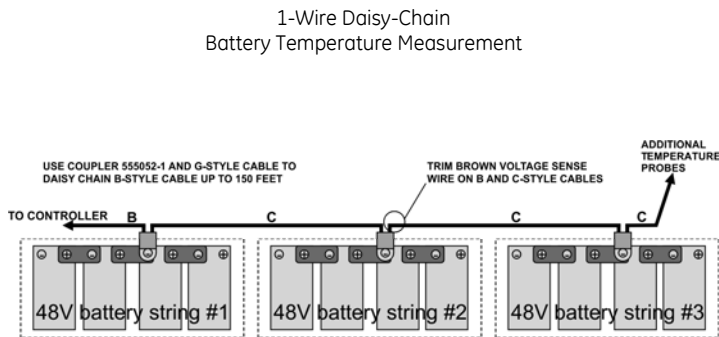

Ordering Codes	Descriptions
CC109142980	QS873A Battery Thermal Probe
150026698	QS873B Ambient Probe
CC848817024	B 10' controller to thermal probe wireset
CC109157434	B 20' controller to thermal probe wireset
CC848822560	C 1' thermal probe to thermal probe wireset
848719803	C 5' thermal probe to thermal probe wireset
CC848822321	C 10' thermal probe to thermal probe wireset
850037334	C 20' thermal probe to thermal probe wireset

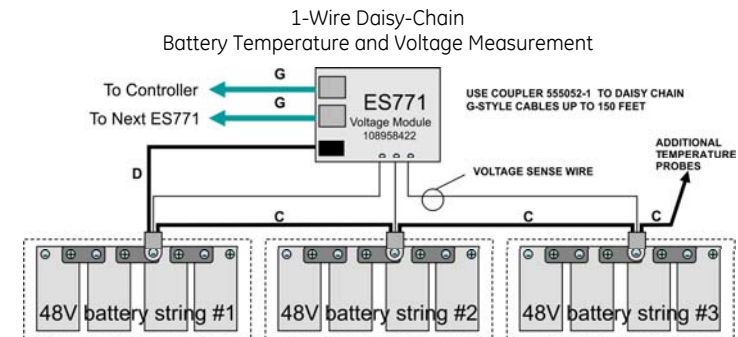

Ordering Codes	Descriptions
108958422	ES771A Voltage Monitor Card
CC848791517	D 2 ½' ES771A to probe wireset
CC848797290	D 6' ES771A to probe wireset
848719829	D 10' ES771A to probe wireset
CC848791500	G 4' ES771A to ES771A or controller wireset
848652947	G 10' ES771A to ES771A or controller wireset



Information: Basic Operation

<p>Controller LEDs - Alarm Status: SYS: Green = Normal Amber = Minor Alarm Red = Critical/Major Alarm ALM: Red = certain user defined alarms</p>	<p>System Parameters: View and change from the factory defaults via: A. LAN port in Local mode via a laptop (web pages) B. Network (web pages) C. Craft Port via laptop and EasyView2 software (or HyperTerminal). D. Controller Display Panel - on some models. Details in <i>Pulsar Edge Controller Family Product Manual</i>.</p>	<p>LAN port Local or Network Set by the jumper setting shown in step 1.</p> <hr/> <p>EasyView2 (GUI) software can be downloaded from www.gecriticalpower.com.</p>
<p>Connect PC via Craft Port</p> <ol style="list-style-type: none"> 1. Connect laptop PC to Craft port. 2. Run EasyView2 program. 3. Follow <i>Operation Web Page / EasyView2</i> 	<p>Connect PC via LAN Port</p> <ol style="list-style-type: none"> 1. Set LAN port to Local - jumper setting shown in Step 1. 2. Connect laptop PC to LAN port. 3. Follow <i>Operation Web Page / EasyView2</i> 4. Set LAN port to Network mode and connect network cable to restore network access. 	<p>Connect PC via Network</p> <ol style="list-style-type: none"> 1. With LAN port set to Network (Step 1). 2. Open a browser or <i>EasyView2</i> on a network connected PC. 3. Follow <i>Operation Web Page / EasyView2</i>

View and Change - Web Page / EasyView2

1. Connect via browser or EasyView2 - default IP address 192.168.2.1
2. Login to the controller - username is not required by default

Access (Default Username)..... Default Password

Read-Only (none)lineage

Read/Write (none) super-user

Read/Write/Password Administration ("admin")..... administrator

3. Select the desired tab - Installation and Settings tabs for configuration.
4. Select the desired item from the items grouped in columns.
5. View and change system parameters as instructed in equipment documentation and in site engineering instructions.

Compatibility: Web Pages have been tested with Internet Explorer versions up to and including version 11.
 EasyView2 has been tested with 32-bit and 64 bit Windows versions up to Windows 8.

EasyView2/Web Login Page



EasyView2/Web Settings Page

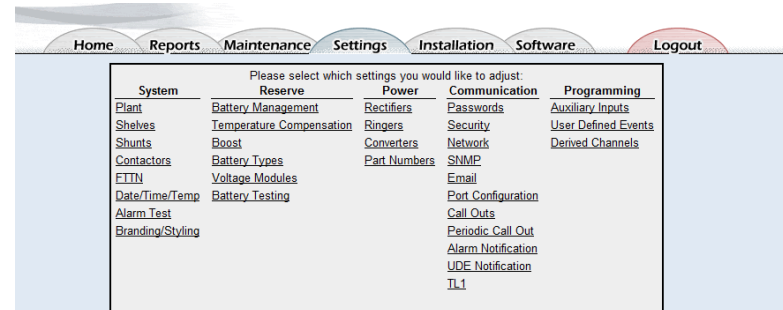

Information: Basic Operation - continued

EasyView2/Web Installation Page

EasyView2/Web Home Page Example

View and Change - Display Panel (on some models)

Most controller features not requiring alpha character input are available via the display panel provided on some models.

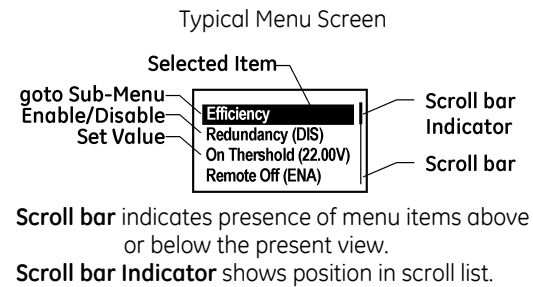
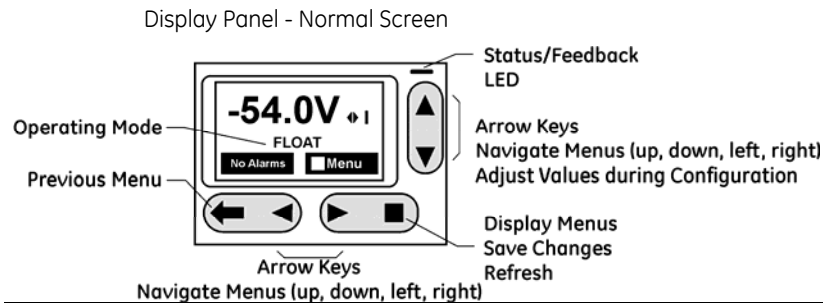

Buttons	Description	
	Navigate	Menu Screens - navigate to make a selection Selected menu items displayed with a value in parentheses are edited by pressing Enter Menu items without a value in parentheses have sub-menus Parameter Edit - ◀ ▶ select the digit to increment or decrement Normal Screen - ◀ ▶ shift display between V and I
	Parameter Change	Parameter Edit - increase or decrease the value of the selected digit Normal Screen - Adjust LCD contrast
	Enter	Menu Screens - Enter a sub-menu Enter a parameter to change, or confirms a parameter change Normal Screen - Enter top level menu
	ESC	Up one menu level or Exit a parameter change without saving



Information: Basic Operation - continued

Clear Missing Devices / Uninstall Equipment

Some alarms indicate that a previously connected device is no longer connected, e.g. Com Fail and FAJ for DIN breakers. Remove the devices from controller memory to clear these alarms.

Clear Missing Devices / Uninstall Equipment command - removes devices no longer connected from memory and ends associated alarms.

Web: Maintenance Tab, Clear Data column: clear missing devices

Display Menu: Control/Operations > Uninstall Equipment - only clears missing devices

Connecting a device to the controller automatically adds it to the connected device memory.



Information: Configuration Menus (display panel)

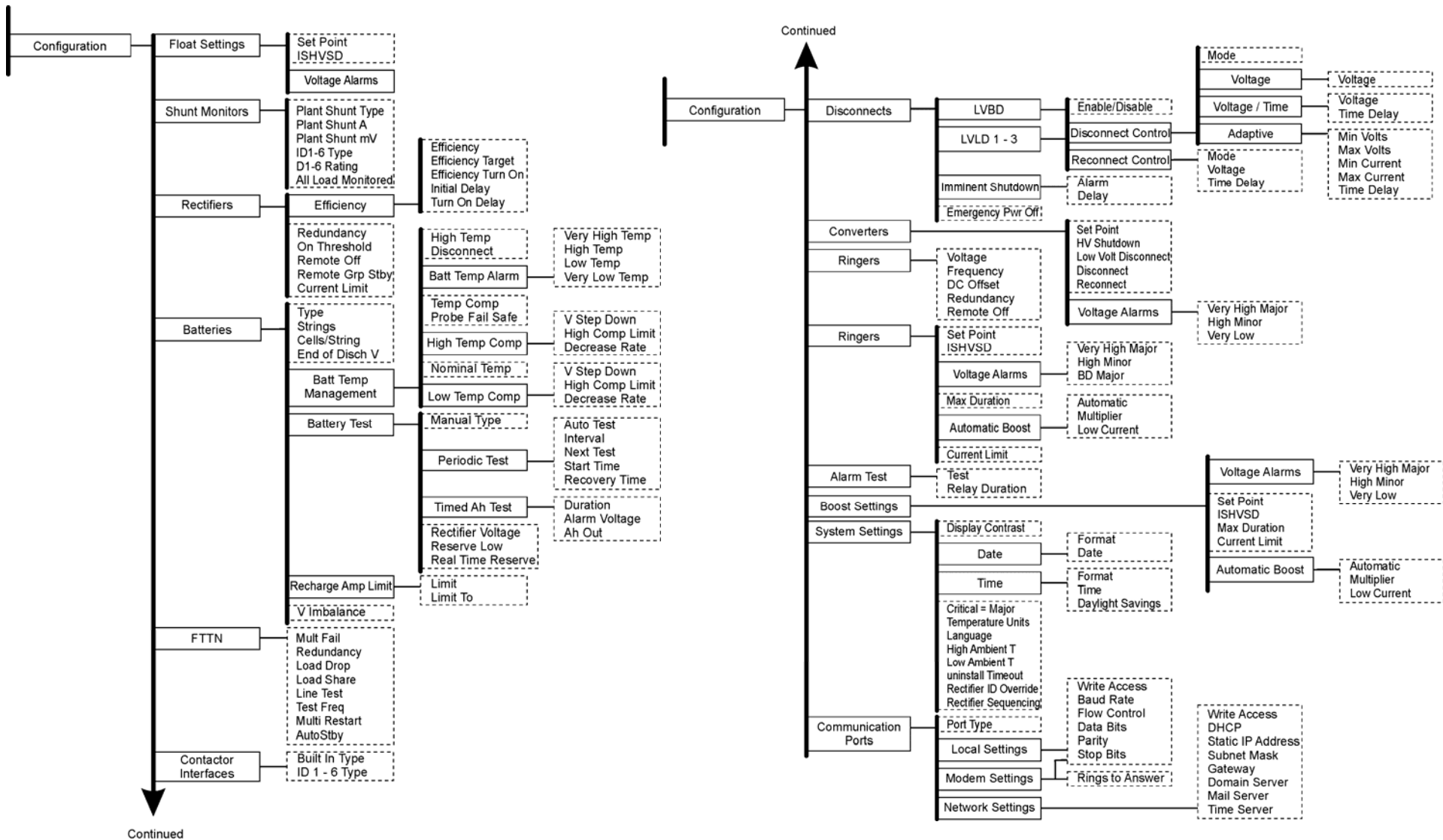

Information: Status and Control/Operations and History Menus (display panel)

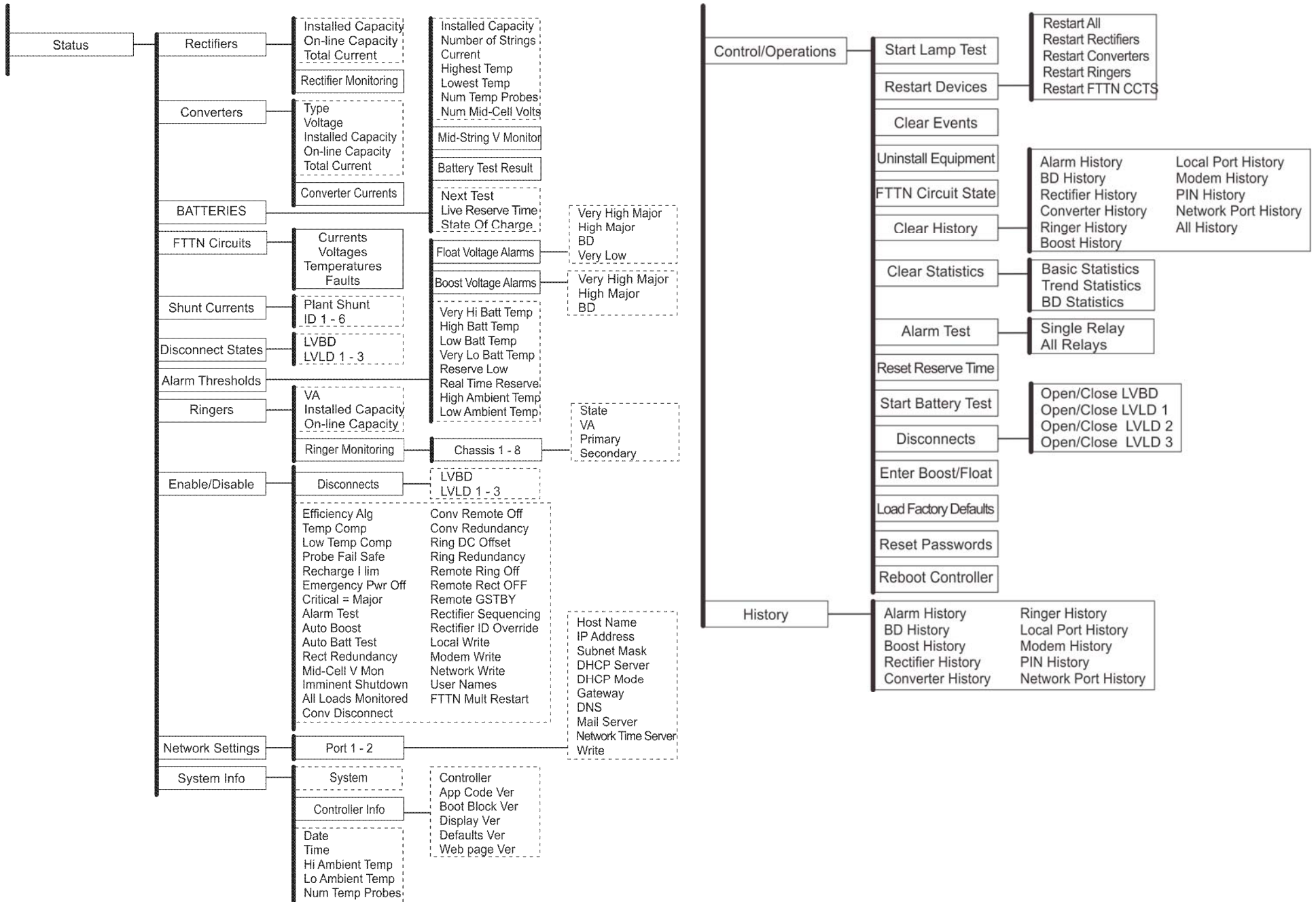

Information - Troubleshooting DC System (1)					
Controller LED	User Interface Display	Rectifier LED	Distribution Module Card LED	Possible Problem	Possible Solution
AMBER	MIN, AC Fail	None	GREEN	Single Rectifier not receiving ac power. AC input circuit breaker has opened. AC input voltage is out of range.	Verify ac power to rectifier is available. Verify rectifier input circuit breaker is closed. If problem not corrected, replace rectifier.
RED	MIN, AC Fail MAJ, Multiple AC Fail MAJ, Battery on Discharge	None	GREEN	Multiple rectifiers not receiving ac power, batteries are powering load. AC input circuit breakers have opened. AC input voltage is out of range. Internal rectifier fault.	Verify ac power to rectifiers is available. Verify rectifier input circuit breakers are closed. If problem not corrected, replace rectifier.
AMBER or RED	MIN, AC Fail MAJ, Multiple AC Fail	None	GREEN	A rectifier, multiple rectifiers, or the entire system has lost AC and one or more rectifiers have been removed from the system while under this condition.	Verify that ac power to all rectifiers is available. Verify that rectifiers all report good AC Issue the uninstall equipment under the operations menu for any rectifier that may have been removed during the AC fail.
RED	MAJ, Battery on Discharge	AC OK DC OK	GREEN	Rectifier output voltage has fallen below the battery on discharge threshold set by the user.	If commercial ac power is present but the system voltage remains low, call your local field representative. Investigate other alarms that may be present such as rectifier related problems.
AMBER	MIN, Rectifier Fail ¹	AC OK ALARM ¹	GREEN	Rectifier output has dropped below 36V, rectifier has entered hiccup mode.	Replace rectifier.
RED	MAJ, Rectifier Fail	AC OK ALARM ¹	GREEN	All rectifier outputs have dropped below 36V, all rectifiers have entered hiccup mode. Defective controller.	Remove controller; if output voltage does not go to set-point previously set by user, call your local field representative.
RED	MAJ, Rectifier Fail ¹	AC OK DC OK	AMBER (Blinking)	One or both of the LVD contactors is open; someone may have manually opened LVD contactor.	Place disconnect switch in ON position.
AMBER	MAJ, Contactor 1 Open	AC OK DC OK	GREEN	Batteries have exceeded temperature threshold set by user.	Call your local field representative.
None	No response.	RED (Blinking)	RED (Blinking)	Controller failure, all devices on the communication bus reporting loss of communication with controller.	Check controller to ensure it is properly inserted into its slot. If so, perform the following steps: Remove the controller board for 1 minute and then reset. If problem persists, replace controller with new controller board. If problem still persists, call your local field representative.

1. DC OK Blinking on some rectifiers.



Information - Troubleshooting DC System (2)					
Controller LED	User Interface Display	Rectifier LED	Distribution Module Card LED	Possible Problem	Possible Solution
AMBER	MIN, Thermal Probe Fail	AC OK DC OK	GREEN	1-Wire thermal probe failed.	Ensure thermal probe is properly connected to thermal probe cable. Ensure cable is properly connected to the rear of the Distribution Module. If problem persists, replace thermal probe per ensuing instructions. If problem still persists, call your local field representative.
RED	MAJ, Fuse Major	AC OK DC OK	RED	One or more of the output circuit breakers or fuses have opened.	Reset circuit breakers or replace fuse.
AMBER	MIN, Rectifier Fail	AC OK ALARM	Normal	Single rectifier thermal alarm: Excessive ambient temperature Multiple rectifier failure	Verify that there is no obstruction of the airflow path. Reset the rectifier by removing the rectifier, waiting approximately 30 seconds, and replacing the rectifier. If problem persists, replace the rectifier. If problem still persists, call your local field representative.
AMBER	MIN, Rectifier Fail	AC OK ALARM Blinking	Normal	Single rectifier thermal alarm: Near thermal shutdown Multiple rectifier failure	
RED	MIN, Rectifier Fail MAJ, Multiple Rectifier Fail MAJ, Battery on Discharge	AC OK ALARM	Normal	Multiple rectifier thermal alarm: Excessive ambient temperature Multiple rectifier failure	
RED	MAJ, High Voltage	AC OK ALARM	Normal	High output voltage from rectifier(s) Rectifier(s) high voltage shutdown Internal rectifier(s) failure	Reset the rectifier(s) by removing the rectifier(s), waiting approximately 30s and replacing the rectifier(s). If problem persists, replace the rectifier. If problem still persists, call your local field representative.
Amber	MIN, Clock Battery Low	AC OK DC OK	Normal	Internal Lithium Battery Is Low	The battery is not designed to be easily field replaced. The controller unit needs to be replaced. Obtain all desired information such as alarm history, statistics, and any field configuration that is different than the standard.
AMBER	MIN, Minor Communication Fail	RED Blinking Single rectifier	GREEN	Rectifier lost communication with controller.	If a rectifier has been removed from an installed/operational system, go to the Control/Operations menu and execute Uninstall Equipment. Reset the rectifier by removing the rectifier, waiting approximately 30 seconds, and replacing. If problem persists, replace the rectifier. If problem still persists, call your local field representative.



Information - Troubleshooting DC System ((3))					
Controller LED	User Interface Display	Rectifier LED	Distribution Module Board LED	Possible Problem	Possible Solution
RED	MAJ, Major Communication Fail	AC OK DC OK	RED (Blinking)	LVD Board lost communication with the controller.	Replace Distribution Module Board. (Note 2) If problem persists, call your local field representative.
GREEN	No Alarm, Individual Shunt Currents displayed at or above their maximum display values (≥600A for loads, ≥800A)	AC OK DC OK	Normal	One or both of the QS871A shunt inputs is open-circuit.	Verify that the respective shunt has its green and yellow wire connections attached used for the current measurements. Verify the shunt connection to the QS871A is good by verifying the green and yellow wire connections from the shunt follows through to the 10-pin connector at the respective QS871A.
GREEN	No Alarm,	AC OK Blinking	Normal	AC present, not within operating limits.	Verify AC input voltage. Reset the rectifier by removing the rectifier, waiting approximately 30 seconds, and replacing the rectifier. If problem persists, replace the rectifier. If problem still persists, call your local field representative.
GREEN	No Alarm,	AC OK DC OK Blinking	Normal	Rectifier Over Load - Current or Power (Normal during battery recharge following discharge.)	If problem persists: Reset the rectifier by removing the rectifier, waiting approximately 30 seconds, and replacing the rectifier. If problem persists, replace the rectifier. If problem still persists, call your local field representative.
GREEN	No Alarm,	AC OK	Normal	Rectifier Standby (Normal during some conditions depending on controller settings.)	Verify controller settings. If problem persists: Reset the rectifier by removing the rectifier, waiting approximately 30 seconds, and replacing the rectifier. If problem persists, replace the rectifier. If problem still persists, call your local field representative.

1. While in hiccup mode, the rectifier will attempt to restart every 10 seconds for a maximum of 3 times.

2. Refer to *Pulsar Edge Controller Family Product Manual* for LVD board removal details.

The power system will continue to power the load while the LVD board is out of the system; however, there will be no possibility of battery backup until the LVD board is replaced.



Information - Troubleshooting Battery Module				
Controller LED	User Interface Display	Battery Module LED	Possible Problem	Possible Solution
AMBER or RED		AMBER or RED		Call your local field representative.
None	No response.	RED (Blinking)	Controller failure, all devices on the communication bus reporting loss of communication with controller.	Check controller to ensure it is properly inserted into its slot. If so, perform the following steps: Remove the controller board for 1 minute and then reset. If problem persists, replace controller with new controller board. If problem still persists, call your local field representative.





Notes

