

BPS Systems -48V Power

BPS48-19-AC5-PS5-DC1E-LVBD

19"/23"
wide

AC input
AC5 - Ind.
Term Block

of
Power
Slots

of
Distribution
Panels

LVBD
option



Important safety instructions

- Save these instructions.
- Read and follow all safety statements, warnings, and precautions in this manual before installing, maintaining or repairing this equipment.
- This equipment is not suitable for use in locations where children are likely to be present.
- This equipment is intended only for use in restricted access areas.

Consignes de sécurité importantes

- Conservez ces instructions.
- Lisez et suivez toutes les consignes de sécurité, les avertissements et les précautions de ce manuel avant d'installer, d'entretenir ou de réparer cet équipement.
- Cet équipement n'est pas adapté à une utilisation dans des endroits où des enfants sont susceptibles d'être présents.
- Cet équipement est destiné uniquement à être utilisé dans des zones à accès restreint.

Safety Statements

- Do not install this equipment over combustible surfaces.
- Rules and Regulations - Follow all national and local rules and regulations when making field connections.
- Compression Connectors
 - U. S. or Canada installations - use Listed/Certified compression connectors to terminate Listed/Certified field-wire conductors.
 - All installations - apply the appropriate connector to the correct size conductor as specified by the connector manufacturer, using only the connector manufacturer's recommended or approved tooling for that connector.
- Electrical Connection Securing: Torque to the values specified on labels or in the product documentation.
- Cable Dress - dress to avoid damage to the conductors and undue stress on the connectors.
- Circuit Breakers and Fuses
 - Use only those specified in the equipment ordering guide.
 - Size as required by the National Electric Code (NEC) and/or local codes.
 - Safety Tested Limits - Refer to the equipment ratings to assure current does not exceed:
 - Continuous Load (List 1) - 60% of protector rating.
 - Maximum Load (List 2 - typically end of discharge) - 80% of protector rating.
 - GMT Style Fuses - Use only fuses provided with safety caps.
- Field-wired Conductors - Follow all National Electric Code (NEC) and local rules and regulations.
 - Insulation rating: 90°C minimum; 105°C (minimum) if internal to enclosed equipment cabinets.
 - Size AC field-wired conductors with 75°C ampacity (NEC) equal to or greater than their panel board circuit breaker rating.
- AC and DC input disconnect/protection - Provide accessible devices to remove input power in an emergency.
- Alarm Signals - Provide external current limiting protection. Rating 60V, 0.5A unless otherwise noted.
- Grounding - Connect the equipment chassis directly to ground. In enclosed equipment cabinets connect to the cabinet AC service ground bus. In huts, vaults, and central offices connect to the system bonding network.

Déclarations de sécurité

- N'installez pas cet équipement sur des surfaces combustibles.
- Règles et réglementations - Suivez toutes les règles et réglementations nationales et locales lors des connexions sur le terrain.
- Connecteurs à compression
 - Installations aux États-Unis ou au Canada - utilisez des connecteurs de compression homologués/certifiés pour terminer Conducteurs de fils de terrain certifiés.
 - Toutes les installations - appliquez le connecteur approprié au conducteur de taille correcte tel que spécifié par le fabricant de connecteurs, en utilisant uniquement l'outillage recommandé ou approuvé par le fabricant de connecteurs pour ce connecteur.
- Fixation de la connexion électrique : Serrez aux valeurs spécifiées sur les étiquettes ou dans la documentation du produit.
- Habillage de câble - Habillez-vous pour éviter d'endommager les conducteurs et une contrainte excessive sur les connecteurs.
- Disjoncteurs et fusibles
 - Utilisez uniquement ceux spécifiés dans le guide de commande de l'équipement.
 - Taille requise par le National Electric Code (NEC) et/ou les codes locaux.
 - Limites de sécurité testées - Reportez-vous aux valeurs nominales de l'équipement pour vous assurer que le courant ne dépasse pas:
 - Charge continue (Liste 1) - 60 % de la cote de protection
 - Charge maximale (Liste 2 - généralement en fin de décharge) - 80 % de la valeur nominale du protecteur.
 - Fusibles de style GMT - Utilisez uniquement des fusibles fournis avec des capuchons de sécurité.
- Conducteurs câblés sur le terrain - Suivez tous les codes électriques nationaux (NEC) et les règles et réglementations locales.
 - Indice d'isolation : 90 °C minimum ; 105°C (minimum) si à l'intérieur des armoires d'équipement fermées.
 - Dimensionnez les conducteurs CA câblés sur place avec un courant admissible de 75°C (NEC) égal ou supérieur à la valeur nominale du disjoncteur du panneau de distribution.
- Déconnexion/protection des entrées CA et CC - Fournir des dispositifs accessibles pour couper l'alimentation d'entrée en cas d'urgence.
- Signaux d'alarme - Fournit une protection de limitation de courant externe. Note 60V, 0.5A sauf indication contraire.
- Mise à la terre - Connectez le châssis de l'équipement directement à la terre. Dans les armoires d'équipement fermées, connectez-vous au bus de terre de service CA de l'armoire. Dans les huttes, les chambres fortes et les bureaux centraux, connectez-vous au réseau de liaison du système.

Precautions

- Install, service, and operate equipment only by professional, skilled and qualified personnel who have the necessary knowledge and practical experience with electrical equipment and who understand the hazards that can arise when working on this type of equipment.
- Disconnect batteries from outputs and/or follow safety procedures while working on equipment. Batteries may be connected in parallel with the output of the rectifiers. Turning off the rectifiers will not necessarily remove power from the bus.
- Do not disconnect permanent bonding connections unless all power inputs are disconnected.
- Verify that equipment is properly safety earth grounded before connecting power. High leakage currents may be possible.
- Exercise care and follow all safety warnings and practices when servicing this equipment. Hazardous energy and voltages are present in the unit and on the interface cables that can shock or cause serious injury. When equipped with ringer modules, hazardous voltages will be present on the ringer output connectors.
- Use the following precautions in addition to proper job training and safety procedures:
 - Use only properly insulated tools.
 - Remove all metallic objects (key chains, glasses, rings, watches, or other jewelry).
 - Follow Lock Out Tag Out (LOTO) procedures: customer specified, site specific, or general as appropriate. Disconnect all power input before servicing the equipment. Check for multiple power inputs.
 - Wear safety glasses.
 - Follow Personal Protective Equipment requirements: customer specified, site specific, or general as appropriate.
 - Test circuits before touching.
 - Be aware of potential hazards before servicing equipment.
 - Identify exposed hazardous electrical potentials on connectors, wiring, etc.
 - Avoid contacting circuits when removing or replacing covers.
 - Use a personal ESD strap when accessing or removing electronic components.
- Personnel with electronic medical devices need to be aware that proximity to DC power and distribution systems, including batteries and cables, typically found in telecommunications utility rooms, can affect medical electronic devices, such as pacemakers. Effects decrease with distance.

Précautions

- Installer, mettre en service et utiliser l'équipement uniquement par du personnel professionnel, compétent et qualifié possédant les connaissances et l'expérience pratique nécessaires en matière d'équipement électrique et qui comprennent les dangers qui peuvent survenir lors de l'utilisation de ce type de Équipement.
- Débranchez les piles des sorties et/ou suivez les procédures de sécurité tout en travaillant sur l'équipement. Les batteries peuvent être connectées parallèlement à la sortie des redresseurs. Éteindre les redresseurs n'enlève pas forcément l'alimentation du bus.
- Ne débranchez pas les raccords de liaison permanents à moins que toutes les entrées d'alimentation ne soient déconnectées.
- Vérifiez que l'équipement est correctement mis à la terre avant de brancher l'appareil. Des courants de fuite élevés peuvent être possibles.
- Exercez des soins et respectez tous les avertissements et pratiques de sécurité lors de l'entretien de cet équipement. L'énergie et les tensions dangereuses sont présentes dans l'unité et sur les câbles d'interface qui peuvent choquer ou causer des blessures graves. Lorsqu'il est équipé de modules de sonnerie, des tensions dangereuses seront présentes sur les connecteurs de sortie de la sonnerie.
- Utiliser les précautions suivantes en plus des procédures appropriées de formation et de sécurité d'emploi:
 - n'utiliser que des outils correctement isolés.
 - Enlevez tous les objets métalliques (porte-clés, lunettes, bagues, montres ou autres bijoux).
 - suivez les procédures de lock out tag out (LOTO): client spécifié, spécifique au site ou général selon le cas. Débranchez toutes les entrées d'alimentation avant d'entretenir l'équipement. Vérifiez l'alimentation de plusieurs entrées.
 - Portez des lunettes de sécurité.
 - respectez les exigences relatives aux équipements de protection individuelle: client spécifié, spécifique au site ou général selon le cas.
 - tester les circuits avant de les toucher.
 - être conscient des dangers potentiels avant d'entretenir l'équipement.
 - identifier les potentiels électriques dangereux exposés sur les connecteurs, le câblage, etc.
 - Évitez de contacter les circuits lors du démontage ou du remplacement des couvercles.
 - utilisez une sangle ESD personnelle lors de l'accès ou de la suppression de composants électroniques.
- Le personnel équipé de dispositifs médicaux électroniques doit être conscient que la proximité des systèmes de distribution et d'alimentation en courant continu, y compris les piles et les câbles, généralement dans les salles de télécommunication, peut affecter les appareils électroniques médicaux, tels que les stimulateurs cardiaques. Les effets diminuent avec la distance.

Information: Tools required

- Cable Crimpers
- Torque wrench (0-240 in-lb / 28 Nm)
- 5/16," 7/16" and 1/2" nut drivers
- Screw Drivers
- Screw Drivers (#1 Flat & #2 Phillips)
- Wire cutters and strippers

Step 1 – Mount the System

Mount the system with a minimum gap of 3 inches behind the system to allow proper airflow.

1. Attach the system to the frame using a minimum of twelve (six on each side) 12-24 screws (provided). Torque to 35 in-lb (4 Nm) – 5/16" socket.

Step 2 – Connect Chassis and DC Reference (CO) Ground

1. Chassis Ground lug – #10 or 1/4" on 5/8" centers (not provided).
Minimum 10 AWG recommended.
Torque 10-32 screws to 30 in-lb (3.4 Nm) – 5/16" Socket.
2. DC reference ground lug – 5/16" or 3/8" on 1" centers (not provided).
Minimum 6 AWG recommended.
Torque to 160 in-lb (18.07 Nm).

Note: If connecting chassis ground to frame surface remove non-conductive frame coating and apply antioxidant for connection.

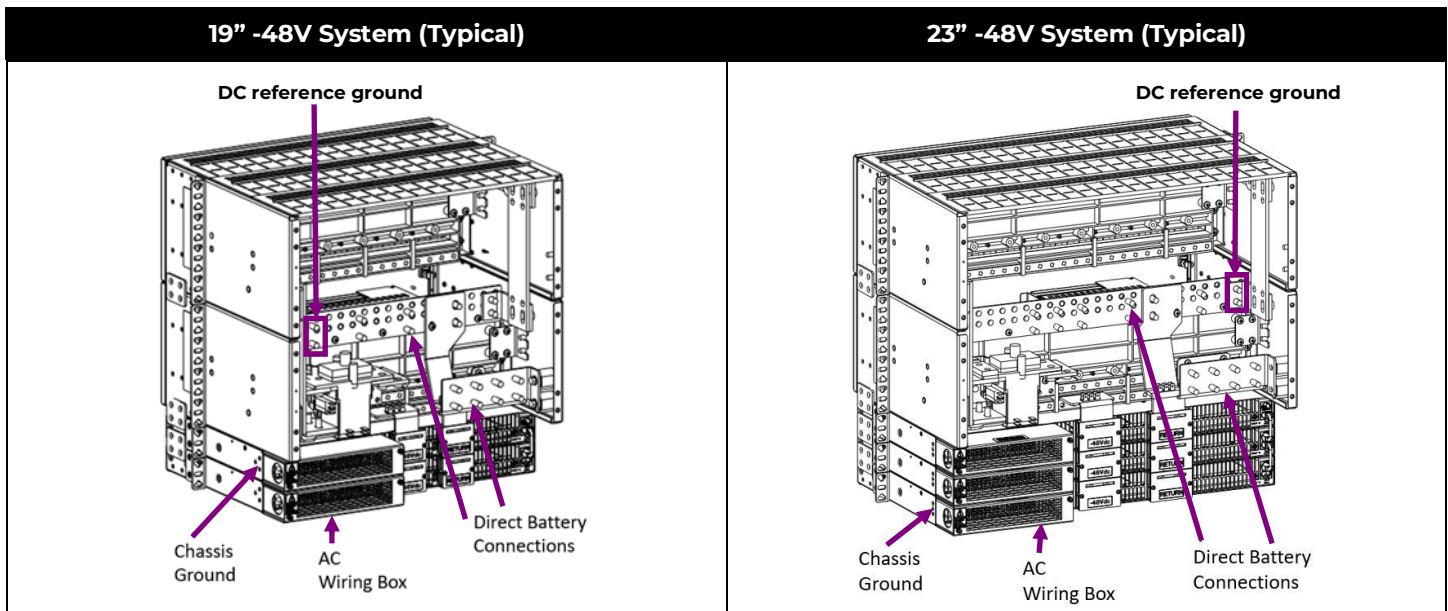

Step 3 – Connect AC inputs

Connect 120/208/240V_{AC} at rear of each rectifier shelf to the detachable input terminal blocks in the wiring box using 3/4" conduit or cord grip.

Danger: Turn OFF and lock-out tag-out the AC source before making AC connections. When connecting to AC mains, follow all local and national wiring rules.

Caution: When routing AC ensure cables do not come in contact with sharp or rough surfaces that may damage insulation and cause a short circuit.

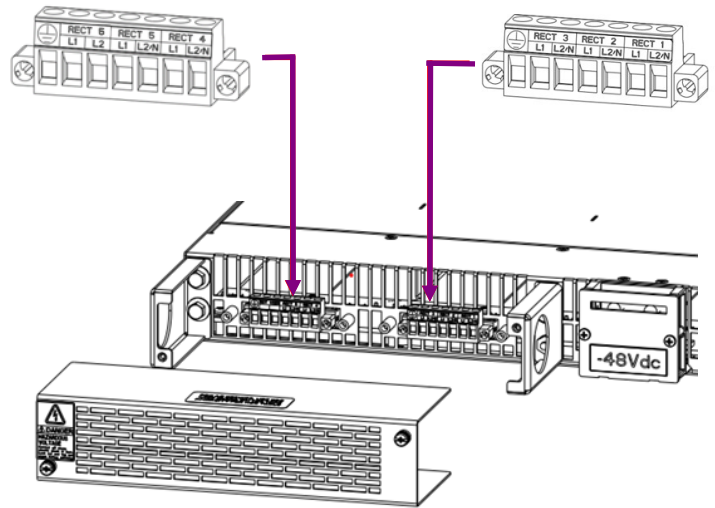

- Individual AC Input per Rectifier. 5 slots for 19" shelves and 6 slots for 23" shelves.
- Maximum branch protection per AC input: 20A
- AC terminal blocks are labeled at each position (L1, L2/N, and Conduit Ground).
- 12 AWG max.
- Strip 0.3" (7mm).
- Torque 4.4 in-lb (0.5Nm).
- Pull on wires to verify connection.



Caution: High touch current may be present.



Connect to earth before connecting to supply.

The following maximum protective conductor current values may be present in their corresponding models:

BPS48-19-AC5-PS15: 107 mArms

BPS48-19-AC5-PS10: 70 mArms

BPS48-19-AC5-PS5: 36 mArms

Information: Rectifier Options

Rectifier	Ordering Code	AC Input Volts	AC Input amps	DC Output Volts	DC Output amps	Recommended AC Breaker	AC Wiring
BP040AC48ATEZ	1600420226A	200-240V _{AC}	12A	48V	40A	15A	11 (19") or 13 (23") 12 AWG in 3/4" conduit per shelf
		110-120V _{AC}	12A	48V	24A	15A	

Information: Temperature ratings of system

Maximum ambient without load derating: 45°C

Maximum ambient above 45°C: 2%/°C up to 65°C

Step 4 – Connect Batteries and DC Output to Loads

The figure to the right shows the DC circuit of the system.

Battery connections may be made to bullet-style distribution positions configured as Battery Breaker Positions or direct to the battery bus.

Caution: Verify battery voltage and polarity with a voltmeter before connecting.

Load connections are made to bullet-style distribution positions configured as Load Breaker Positions.

Distribution panels are each equipped with 20 (19" panel) or 26 (23" panel) bullet-style distribution positions. Each position is selectable between battery input or load output.

Breaker sizes up to 250A, TPS fuses to 70A and GMT fuses to 12A are available.

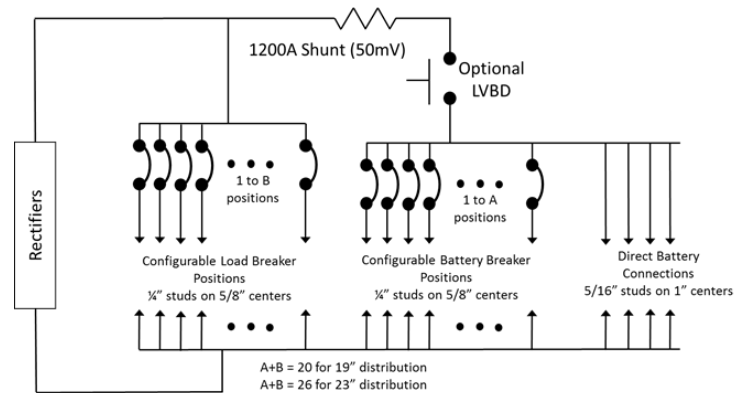

Lug Landings

	Distribution	Battery Bus
Landings	1/4"-20 studs on 5/8" centers Lug tongue width 0.68" max	5/16"-18 studs on 1" centers
Torque	65 in-lb - 7/16" socket	160 in-lb - 1/2"

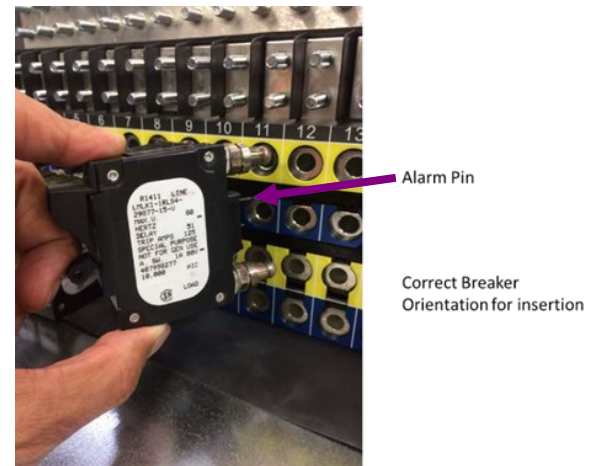
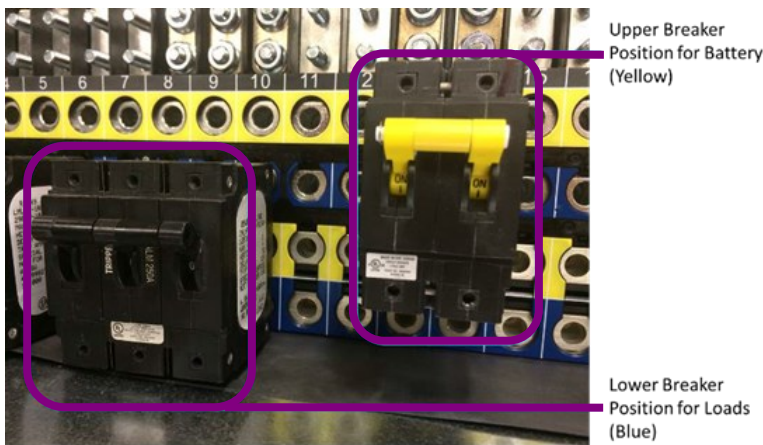

Two multi-pole adapters are required for each multi-pole breaker - see illustration, right

Multi-Pole Adapter Kits – 2 required per breaker			
	CC848756916	850021775	850021955
Poles	2	2	3
Lug Landings	1/4" x 5/8"	3/8" x 1"	3/8" x 1"

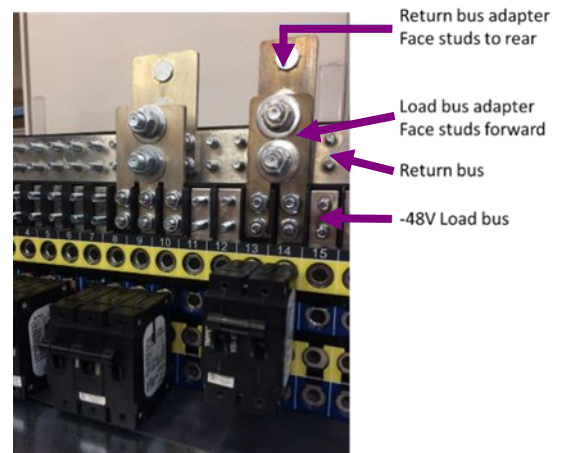

Step 5 – Set Controller alarm relay jumpers

Pulsar Plus

Set jumpers 1 thru 10 for the ten alarm relays as Close on Alarm or Open on Alarm; Factory default setting is Open on Alarm.

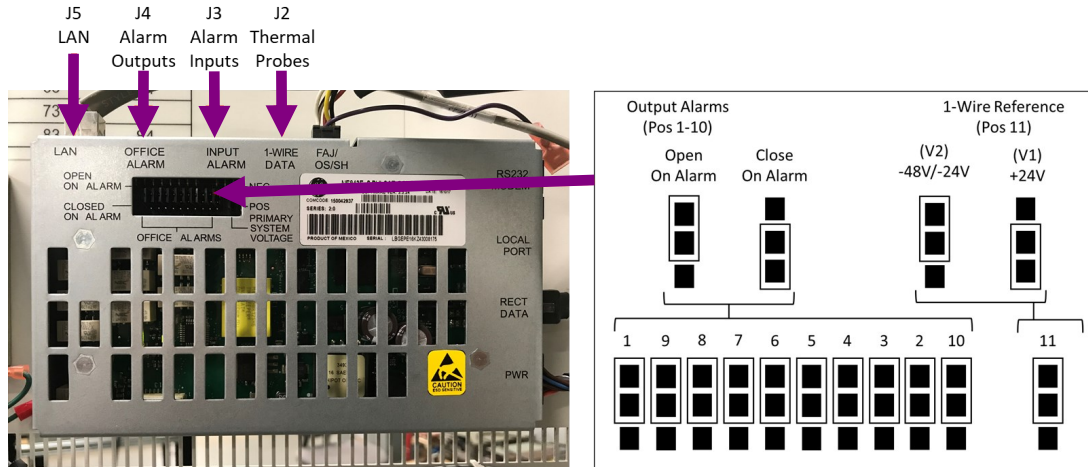

Step 6 – Set Controller Jumpers

Connect per site engineering instructions.

Pulsar Plus - Connect to J2, J3, J4, and J5.

See Information Controller Connections & Information Battery Connections.

Step 7 – Rectifier Installation

Caution: The rectifier latch is not a carrying handle.

1. Open the latch and slide the rectifier into the rectifier slot approximately $\frac{3}{4}$ of the way.
2. Slide the rectifier into the slot until it engages fully into the backplane connector of shelf.
3. Close the latch to lock rectifier into slot.
4. Alarm LED will blink red as controller identifies the rectifier and begins communication.



To remove a rectifier:

1. Open latch fully to release and remove.
2. Controller Menu - Control/Operations - Uninstall Equipment to clear alarm.

Step 8 – Initial Startup

Verify that all AC, DC, GND and Controller connections are complete and secure.

Using a multimeter, verify system reference ground and chassis ground resistance to side ground bar is less than 0.1 Ohms. With rectifiers and converters unplugged as well as all load breakers on and AC breakers off, verify resistance of battery bus to ground is greater than 1MΩ. If being operated as an ungrounded system, verify both positive and negative bus measurement to each other and ground is greater than 1MΩ.

Turn on AC input breakers. If there are no alarms, make required adjustments to the default settings on the controller for this installation.

Step 9 – Configure Controller

Verify and edit controller basic configuration parameters per site engineering instructions.

Refer to Galaxy Pulsar Plus Product Manual for additional information.

Information: Controller Default Voltage Settings

Parameter	Range	Valve-Reg (Default)	Flooded	NiCd
Rectifier Selective High Voltage Shutdown	-50 to -60V	58.50	58.50	58.50
High Voltage Major Alarm	-50 to -60V	57.00	57.00	57.00
High Voltage Minor Alarm	-50 to -60V	56.00	56.00	56.00
Rectifier/System Float Voltage	-42 to -56.5V	54.48	52.08	54.40
Battery on Discharge Alarm	-46 to -55V	51.00	50.00	51.00
Very Low Voltage Alarm	-40 to -51V	46.00	46.00	46.00
Rectifier On Threshold	-40 to -51V	44.00	44.00	44.00

Information: Battery Monitoring Connections

Battery Monitoring is accomplished with a “Daisy Chained” series of probes connected to J2. The Probes monitor battery temperature and voltage (ES771 required to monitor voltage). Bolt the Probe under the “-” terminal connector hardware; NOT under the connecting lug.

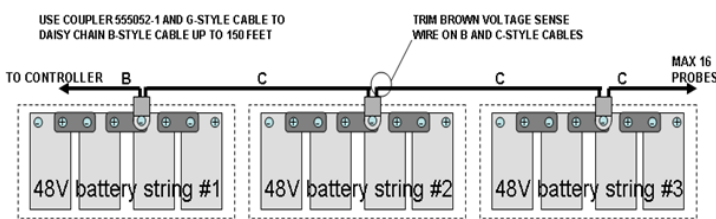

Temperature Measurement

Ordering Code	Description
CC109142980	QS873A Thermal Probe
CC848817024	B 10' controller to thermal probe wireset
CC109157434	B 20' controller to thermal probe wireset
CC848822560	C 1' thermal probe to thermal probe wireset
848719803	C 5' thermal probe to thermal probe wireset
CC848822321	C 10' thermal probe to thermal probe wireset

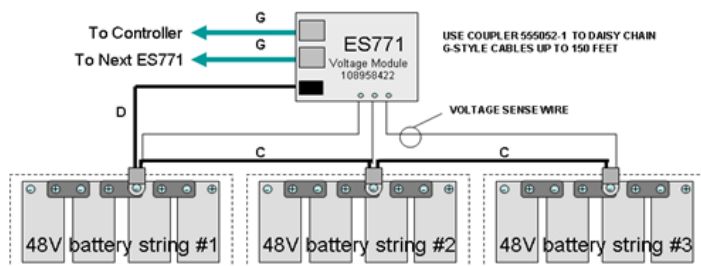

Temperature and Voltage Measurement

Ordering Code	Description
108958422	ES771A Voltage Monitor Card
CC848791517	D 2 ½' ES771A to probe wireset
CC848797290	D 6' ES771A to probe wireset
848719829	D 10' ES771A to probe wireset
CC848791500	G 4' ES771A to ES771A or controller wireset
848652947	G 10' ES771A to ES771A or controller wireset

Information: Controller Connections

Alarm Outputs

Alarm relays are factory set to Open On Alarm. If Close On Alarm is desired adjust controller alarm jumpers. See diagram in step 5 for the location of the controller alarm jumpers. Connector J4 provides access to the primary customer alarm outputs. J4 is a 20-pin latching connector.



Alarm Output Cables	
CC848890137	5 ft.
CC109157442	15 ft
CC848817635	50 ft
CC848817643	150 ft

Standard Controller Alarm Output Defaults		Pin	Color
PCR	Power Critical	1	BL
PCR_C	Power Critical_C	11	BL/BK
PMJ	Power Major	2	O
PMJ_C	Power Major_C	12	O/BK
PMN	Power Minor	3	G
PMN_C	Power Minor_C	13	G/BK
R1	Battery On Discharge	4	W
R1_C	Battery On Discharge_C (BD_C)	14	W/BK
R2	Very Low Voltage (VLV)	5	BK
R2_C	Very Low Voltage_C (VLV_C)	15	BK/W
R3	Fuse Alarm Major (FAJ)	6	BL/W
R3_C	Fuse Alarm Major_C (FAJ_C)	16	BL/R
R4	AC Fail (ACF)	7	O/R
R4_C	AC Fail_C (ACF_C)	17	R
R5	Rectifier Fail (RFA)	8	G/W
R5_C	Rectifier Fail_C (RFA_C)	18	R/G
R6	Mult. Rectifier Fail (MRFA)	9	W/R
R6_C	Mult. Rectifier Fail_C (MRFA_C)	19	R/W
R7	High Voltage (HV)	10	BK/R
R7_C	High Voltage_C (HV_C)	20	R/BK

Alarm Inputs

Default alarm descriptions may be changed as needed using web pages. J3 is a 10-pin latching connector.



Alarm Input Cables	
CC848890153	5 ft.
CC848865980	15 ft
CC848817651	50 ft
CC848817668	150 ft

Standard Controller Alarm Input Defaults		J3 Pin	Color
Air Con Fail		1	BK
Air Con Fail_Return		8	V
Door Open		2	BR
Door Open_Return		8	V
Aux PMJ Input		3	R
Battery Test/GSTR		4	O
Battery Test_Return		9	S
EPO		5	Y
EPO_Return		10	W
Hi ext. Temp.		6	G
Hi ext. Temp._Return		8	V
Low ext. Temp.		7	BL
Low ext. Temp._Return		8	V

Information: Controller Basic Operation

View and change system parameters from the factory defaults via,

1. Controller Display
2. RS232 port located on the front of controller. Consult technical support for additional information.
3. J5 LAN port web pages using a laptop with browser. LAN port Server mode is for local laptop connection. Set the LAN port to Server:

Controller Alarm Status: The display changes colors; Green=Normal, Amber=Minor Alarm, Red=Critical/Major Alarm

Some alarms may occur during initial installation; eg: thermal probe fail or Major/Minor communication fail.

Clear these alarms: Via Controller Display: follow the menu path;

Menu > Control/Operation > Clear Events or Uninstall Equipment.

Verify Basic Installation Settings: Date, Time, Battery Type, number of strings and float voltage

Menu > Configuration > System Settings and Menu > Configuration > Batteries.

Front Panel

View and change system parameters from the factory defaults via the front panel:

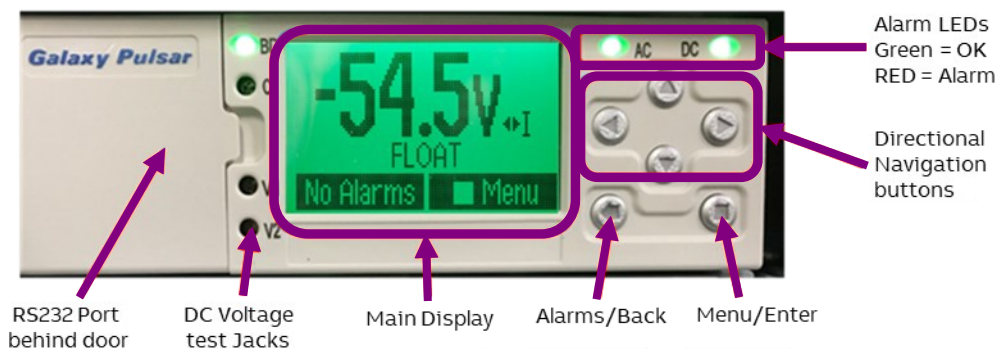

Controller Front Panel Display and Controls

The main menu can be accessed using the Menu/Enter button.

The basic menu structure for navigation is shown below.

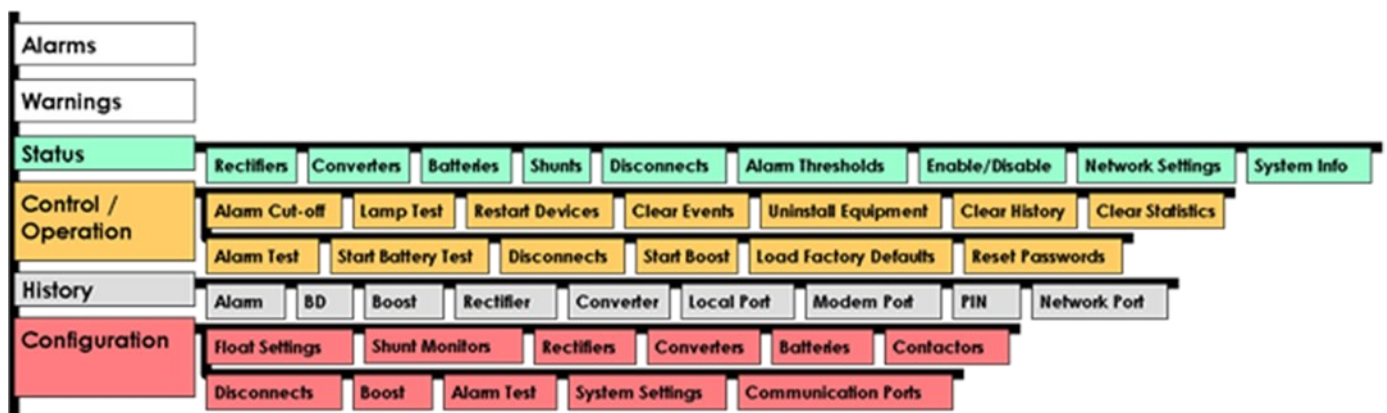

Front Panel Menu Structure - Overview

Information: Controller Basic Operation (continued)

Most user configurable parameters can be accessed from the front panel. Additional configuration and user convenience and visibility is enhanced by access through the LAN port using the built-in web pages.

Configuration > Communication Ports > Network Settings > DHCP > mode to SERVER.

Once the LAN port is configured as a server, the laptop can be connected to the LAN port, using a standard ethernet cable. Use a standard web browser to access the controller web pages at default IP address: 192.168.2.1

Warning: Do not connect LAN port to a network when set to Server mode. Set the controller LAN port to Client or Static before connecting to the network. Static is the factory default setting and the typical setting for most networks.

Once connected to the controller web server a log on screen should be visible:



Logon Screen - web view

Factory Default password is “Administrator” and should be used for initial logon. It is highly recommended that one of the first activities should be to change the default password(s).

The screenshot shows the home page of the controller web interface. At the top, there is a navigation menu with tabs: Home, Reports, Maintenance, Settings, Installation, Software, and Logout. Below the menu, the user is logged in as 'ADMINISTRATOR' on '02/28/2023' at '09:51:15' from IP '172.16.10.98' using 'APP: 4.5.37' and 'WEB: 4.5.37'.

The main content area is divided into several sections:



- System status (NE843_MV1):** Displays site information (n/a), primary bus voltage (-52.03 V) and current (151.7 A), secondary bus voltage (0.0 V) and current (0.0 A), state (FLOAT), plant type (-48V), serial number (LBELPC22KZ08041043), date (02/28/2023), time (09:51:16), and ambient temperatures (24 C).
- Batteries:** Shows installed and online capacity (0 Ah), state of charge (0.0%), total current (0.0 A), on discharge status (NO), model (VALVE-REG), number of strings (0), reserve time (NO BATTERY CONFIG), and temperature/voltage probe counts.
- System configuration (Plant):** Lists rectifier capacities (222 A installed and online), normal rectifier drain (151.5 A), and a status legend for various rectifier states.
- Alarm status:** A table showing no active alarms or warnings.

Severity	Event	Date	Time
-	no alarms	-	-
-	no warnings	-	-
- Contactor status:** A table showing the status of four contactor interfaces.

Description	Type	Current
Plant Current	BATTERY	0.0 A
Distribution Current 1	BATTERY	0.0 A

Home Page – Web View

Information: Rectifier Status LEDs

Condition	 AC OK Green	 DC OK Green	 Fault Red
Normal	ON	ON	OFF
Rectifier Fail	ON	OFF	ON
AC present but not within limits	Blinks	OFF	OFF
AC not present	OFF	OFF	OFF
DC over current	ON	Blinks	OFF
DC standby (remote)	ON	OFF	OFF
Communication failure	ON	ON	Blinks

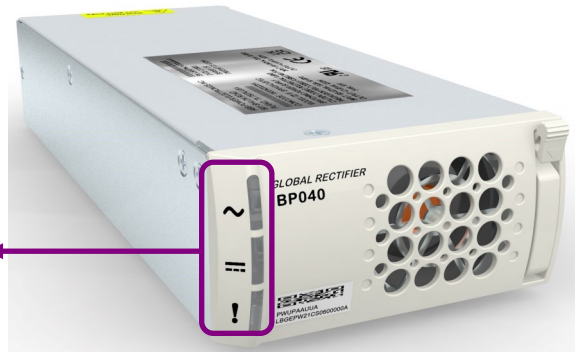

Specifications and Application

Specifications and ordering information are in the BPS Ordering Guide available at omnionpower.com.

External Surge Protective Device (SPD) is required on all AC inputs.

Equipment and subassembly ports:

1. are suitable for connection to intra-building or unexposed wiring or cabling;
2. can be connected to shielded intra-building cabling grounded at both ends.

Grounding / Bonding Network – Connect to an Isolated Ground Plane (Isolated Bonding Network) or an Integrated Ground Plane (Mesh-Bonding Network or Common Bonding Network).

Installation Environment – Install in Network Telecommunication Facilities, OSP, or where NEC applies.

Battery return may be either Isolated DC return (DC-I) or Common DC return (DC-C).

Reference Documents

These documents are available at omnionpower.com.

Document	Title
CC848815341	Galaxy Pulsar Plus Product Manual BPS ordering Guide (aka product line brochure)

Change History (excludes grammar & clarifications)

Revision	Date	Description of the change
1.0	01-19-2023	Initial release
2.0	04-06-2023	Added Rectifier Status LED Table, Added temperature ratings of system
2.1	11-08-2023	Updated as per OmniOn template

OmniOn Power Inc.

601 Shiloh Rd.
Plano, TX USA

omnionpower.com

We reserve the right to make technical changes or modify the contents of this document without prior notice. OmniOn Power does not accept any responsibility for errors or lack of information in this document and makes no warranty with respect to and assumes no liability as a result of any use of information in this document.

We reserve all rights in this document and in the subject matter and illustrations contained therein. Any reproduction, disclosure to third parties or utilization of its contents – in whole or in parts – is forbidden without prior written consent of OmniOn Power. This document does not convey license to any patent or any intellectual property right. Copyright© 2023 OmniOn Power Inc. All rights reserved.